



BCB

Tiger Bulb Flat Bar Anchor/Clamp



ORIGINAL INSTRUCTION GUIDE

- PLEASE PASS ONTO OPERATOR

Sticker here



www.tigerlifting.com

Instruction Guide Tiger BCB En 201803 v1.0





Operator Instruction Guide



MUST READ BEFORE USE

1. It is important that this manual is read and fully understood and that all instructions are followed before using the Tiger product.
2. The product should be used by a trained and or experienced person who understands its use and will operate the unit in a responsible and safe manner.
3. Inspect the product for any damage or wear before use. Ensure the fixed jaw and cam is free from any defects. Do not use the product if it is not in good working order.
4. The supplier takes no responsibility for any consequential loss or damage if the product has been dismantled or altered by an unauthorised person, especially if original parts were not used to repair the machine.
5. Apply the clamp to the beam/bulb flat bar in the open position, close the clamp ensuring that the clamp is fully closed.
6. The adjusting screw must be fully hand tight before any load is applied; failure to do so could result in serious injury to persons or damage to equipment.
7. Do not attempt to overload the machine as this could cause damage to person or equipment.
8. Do not use the clamp in the open position or for lifting flat plate sections.
9. Always ensure the product is used or repaired by a competently trained person.

Contents:

1. Safety Information	2	6. Manufacturer Testing and Verification	4
2. Function/Operation	2	7. Technical Data	4
3. Inspection	3	8. Product Warranty and Warnings	5
4. Maintenance	3	9. Inspection Log	6
5. Transport, Storage, Decommissioning and Disposal	3		

For details of the full Tiger product range visit our website: www.tigerlifting.com

Due to our policy of continual product development, dimensions, weights and specifications may change without prior notice.

© Copyright Tiger Lifting UK Limited. No part of this manual shall be reproduced, transmitted, transcribed, translated into any language human or electronic, stored in any electronic retrieval system, in any form without the written permission of Tiger Lifting UK Limited, Alnwick, UK



1. Safety Information

The operating company is responsible for the proper and professional instruction of the operating personnel. The personnel responsible for operation, maintenance or repair of the product must read, understand and follow these operating instructions. These instructions are intended to make the user familiar with the product and enable them to use it to the full extent of its intended capabilities.

The operating instructions must always be available at the place where the product is operated. Apart from the operating instructions and the accident prevention act valid for the respective country and area where the product is used, statutory regulations and procedures along with the commonly accepted regulations for safe and professional work must also be adhered to. The indicated protective measures will only provide the necessary safety if the product is operated correctly and installed and/or maintained according to the instructions. The operating company must be committed to ensure safe and trouble-free operation of the product.

Health and Safety at Work

All equipment must be maintained and tested to meet relevant statutory regulations when put to use. It is the responsibility of every company to ensure that their employees have been fully and properly trained in the safe operation of their equipment.

Equipment Labelling

The identification label/name plate details the product type, model, manufacturer, working load limit (WLL), serial number and the bulb range. The CE marking indicates compliance with the essential health and safety requirements of the Machinery Directive 2006/42/EC.



2. Function/Operation

The Tiger BCB bulb bar anchor is designed for attaching to bulb profiles of bulb flat bars approved for lifting applications. The bulb bar anchor provides a semi-permanent lifting point. The large integrated shackle gives easy connection for all different types of lifting machines.

Our BCB bulb flat bar anchor can be side loaded up to 45° and cross loaded up to 15° without derating the unit, whilst still maintaining a 4:1 factor of safety.

The working load limit specified on the label/name plate is the maximum load which can be applied to the product in service. The clamp must only be attached to structures which are approved and recommended to carry or sustain the maximum safe working loads which will be applied. We advise that structural calculations are carried out on all beams/bulb flat bars and supporting steel work by qualified engineering departments to ensure safe operation.

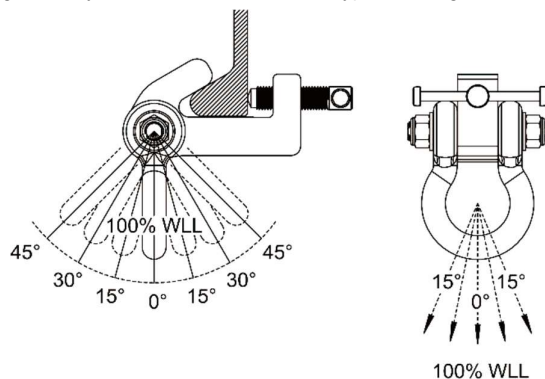

To open the clamping jaw, turn the adjusting screw anti-clockwise.

Unscrew the clamp so will fit the bulb flat bar section. Fit the clamp onto the bulb flat bar section. To tighten the clamp onto the section, turn the adjusting screw clockwise. The adjusting screw must be fully hand tight before any load is applied; failure to do so could result in serious injury to persons or damage to equipment. Check the clamp is of the correct profile and size, or correctly adjusted, for the section size. Ensure the clamp is strong enough for the full load that will be imposed. Ensure the lifting appliance is compatible with the clamp and that hooks or other attachments fit freely into the shackle of the clamp.

Before removing it from a beam/bulb flat bar, make sure there is no load on the clamp.

The BCB clamp is designed for static use. Moving the position of the clamp should only be carried out by a qualified person and must never be done while the clamp is loaded. If two clamps are to be used in tandem the use of ancillary equipment may also be necessary, eg spreader beam. Care must be taken to ensure no one clamp takes more than its working load limit (WLL).

! WARNING

- Never** use clamps which are unidentified or uncertified for lifting applications.
- Never** replace bolts, shackles etc without consulting the supplier or an authorised repairer.
- Never** throw or drop clamps.
- Never** use clamps on damaged or distorted beams/bulb flat bars.



- Never** force or wedge hooks of lifting appliances into the anchor point.
- Never** attach a load, hoist or any other object to any part of the clamp other than the anchor point.
- Never** attempt to move the clamp under load.
- Never** allow a load attached to the clamp to swing or spin.
- Never** work near or under suspended loads.
- Never** use the clamp for lifting beams. It is a suspension point.
- Never** use the clamp in the open position

3. Inspection

According to national and international accident prevention and safety regulations, hoisting equipment must be inspected:

- in accordance with the risk assessment of the operating company
- prior to initial operation
- before the unit is put into service for any subsequent use
- after substantial changes
- however, at least once per year, by a competent person.

Note: Actual operating conditions (e.g. operation in galvanizing facilities) can dictate shorter inspection intervals.

In the event of any defects refer the clamp to a Competent Person for thorough examination.

Examinations should include the following:

- Examine clamp for wear and distortion.
- Examine adjusting screw for straightness and function. Check threads for damage, wear and stretch.
- Examine adjusting screw handle for distortion and loose bar end stops. Ensure it is not bent or damaged.
- Examine for loose or missing fasteners, stops or nameplates.
- Examine for corrosion.
- Examine for illegible labels and markings.

An Inspection Log is included in Chapter 9 for making a dated record of any required inspections.

4. Maintenance

The equipment should not be dismantled for cleaning or maintenance, except by an authorised competent person. Clean the clamp. Lubricate any moving parts. Correctly secure all fastenings.

5. Transport, Storage, Decommissioning and Disposal

Transporting the unit:

- Do not drop or throw the unit, always deposit it carefully.
- Use suitable transport means. These depend on the local conditions.

Storing or temporarily taking the unit out of service:

To ensure the continuing integrity of the unit you should store the unit in conditions that do not lead to damage or deterioration.

Therefore:

- Inspect clamps and accessories before placing into storage.
- **Never** return damaged clamps to storage.
- The unit should be secured against unauthorised and unwarranted use.
- Store the unit in a clean and dry place.
- Wipe off all dirt and water.
- A light oil film should be applied to moving parts.
- Protect the unit including all accessories against contamination, humidity and damage by means of a suitable cover.
- Protect against corrosion.
- If the unit is to be used again after it has been taken out of service, it must first be inspected again by a competent person.

Disposal

When the product comes to the end of its lifecycle, after taking the unit out of service, recycle or dispose of the parts of the unit respecting local and national environmental regulations.



6. Manufacturer Testing and Verification

This product was manufactured under our single-unit control of quality and was passed with strict inspection in accordance with our inspection standards. The operating temperature range is -50°C (-58°F) to +50°C (+122 °F).

Capacity (tonne)	WLL (kg)	Test Load (kg)
1.5	1500	2250
3	3000	4500

Declaration of Conformity

Tiger BCB Clamps have a 4:1 factor of safety. They are tested in line with the requirements within applicable sections of ASME B30.20 and EN13155:2003+A1:2009. All items comply with the essential health and safety requirements of the Machinery Directive 2006/42/EC. Tiger clamps are third party verified by SGS Certificate Number MDC 1302.

7. Technical Data

Product Code	Capacity (tonne)	Dimensions (mm)							Weight (kg)
		A	B	C	D	E	F	G	
BCB-0150	1.5	160-240	36	173-200	125-151	58	71	22	3.6
BCB-0300	3.0	240-320	42	214-241	155-182	68	94	25	6.4

A=bulb flat width

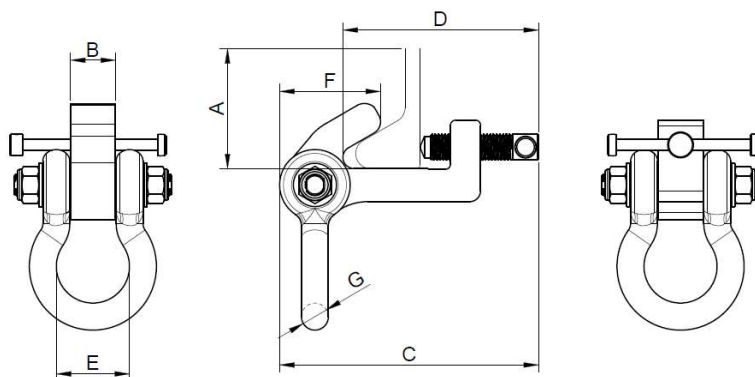

Due to our policy of continual product development, dimensions, weights and specifications may change without prior notice.

8. Product Warranty and Warnings

Definitions

'Customer' means the individual, firm, company or other party with whom the Company contracts;

'Company' means Woo Sing Industrial Co., Ltd;

'Contract' the contract between the Company and the Customer for the sale and purchase of this product;

'Defective Goods' goods, parts or materials, which by reason of fault or incorrect design or workmanship, are found to be defective or fail or are unable to perform in accordance with a Contract;

One Year Limited Warranty

The Company makes every effort to assure that its products meet high quality and durability standards and extends the following warranty to the Customer of new products manufactured by the Company:

- The Company warrants that this product, when shipped, shall be free from defects in materials and workmanship under normal use and service and the Company shall, at its election, repair or replace free of charge any Defective Goods, provided that all claims for defects under this warranty shall be made in writing immediately upon discovery and, in any event, within one (1) year from the date of purchase of this product by the Customer and provided, further, that Defective Goods shall be kept for examination by the Company or its authorised agents or returned to the Company or an authorised service centre upon request by the Company.
- The Company does not warrant components of products provided by other manufacturers. However to the extent possible, the Company will assign to the "Purchaser" applicable warranties of such other manufacturers.
- Except for the repair or replacement mentioned in (1.) above, which is the Company's sole liability and Customer's exclusive remedy under this warranty, the Company shall not be responsible for any other claims arising out of the purchase and use of this product, regardless of whether the Customer's claims are based on breach of contract, tort (including negligence), breach of statutory duty, or otherwise, including claims for any loss of profit, goodwill or business opportunity or any indirect or consequential loss arising under or in connection with the Contract.
- This one year limited warranty is conditional upon the installation, maintenance and use of this product pursuant to the product manuals prepared in accordance with content instructions by the Company. The warranty on this product does not apply to defects due directly or indirectly to misuse, abuse, negligence or accidents. This warranty does not apply if the product has been subjected to improper fittings, alignment or maintenance.
- The Company shall not be responsible for any loss or damage caused by transportation, prolonged or improper storage or normal wear and tear of this product or for loss of operating time.



6. This warranty shall not apply to this product if it has been fitted with or repaired with parts, components or items not supplied or approved by the Company or which have been modified or altered.
7. The Company limits all implied warranties to the period specified above from the date the product was purchased by the Customer.
8. Except as stated herein, any implied warranties or merchantability and fitness are excluded.

If our inspection discloses a defect, the Company will repair, replace the product or refund the purchase price, if we cannot readily or quickly provide a repair or replacement and if you are willing to accept such refund. The Company will return repaired or replacement products at The Company's expense, but if it is determined there is no defect, or that the defect resulted from causes not within the scope of Tiger Lifting's warranty, then the Customer must bear the cost of storing and retrieving the product.

! WARNING

The use of this product is beyond the control of Tiger Lifting. The warranty of this product is limited to the replacement cost of this product should it be found to be defective in material and/or workmanship. The warranty is void if the product is damaged, worn or used improperly. Normal wear and tear is not considered grounds for replacement. The Tiger Lifting product warranty does not apply where there has been excessive overloading of the product.

Disclaimer

We believe that the information in this document, including technical information and any advice, is reliable although we give no guarantee as to its accuracy or completeness. The user of our products must determine if the product, either used alone or conjunction with other products, is suitable for their purpose and assumes all risk and liability in connection with those decisions. We have made every effort to make sure this document is accurate. The information contained in this document does not form part of any contract.

Please also refer to our terms and conditions which can be found at: www.tigerlifting.com/terms-conditions/



 **Tiger HQ Taiwan**

Woo Sing Industrial Co., Ltd
6F, No. 118-1,
ZhongZheng Road
Shilin Dist.,
Taipei City
11145

Taiwan

 +886-2-2831 3035

 +886-2-2834 0188

 info@tigerlifting.com.tw

 **Tiger UK and Europe**

Tiger Lifting UK Limited
Unit 1, Greensfield Industrial Estate,
Willowburn Avenue,
ALNWICK,
NE66 2DG
UK

 +44 1665 605130

 +44 1665 603185

 info@tigerlifting.com

 **Representative in Europe**

 **Tiger North America**

Tiger Lifting NA
38381 N. Robert Wilson Rd.
Gonzales, Louisiana
70737

USA

 +1 225-647-1312

 +1 833-681-3057

 sales@tigerliftingna.com

 **Tiger China – Sales Office**

 +86 (0) 21 3133 2638

 +86 138 2377 3024

 info@tigerlifting.com.cn

www.tigerlifting.com



© Copyright Tiger Lifting UK Limited. No part of this manual shall be reproduced, transmitted, transcribed, translated into any language human or electronic, stored in any electronic retrieval system, in any form without the written permission of Tiger Lifting UK Limited, Alnwick, UK

www.tigerlifting.com

Instruction Guide Tiger BCB En 201803 v1.0





Bulb Flat Bar Anchor/Clamp (BCB)1.5T~3T EXPLODED VIEW & PARTS LIST

For BCB models BCB-0150, BCB-0300

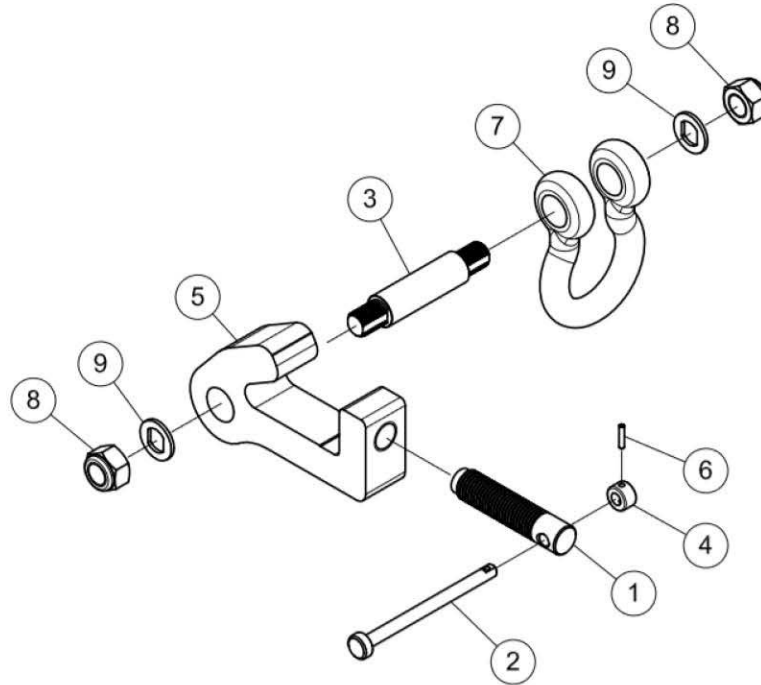

Parts #	Part Name	Quantity	Parts #	Part Name	Quantity
1	Fix Shaft	1	6	Handle Pin	1
2	Handle	1	7	Shackle	1
3	Shackle Pin	1	8	Nut	2
4	Handle Nut	1	9	Washer	2
5	Anchor Body	1			