

OPERATION AND MAINTENANCE MANUAL

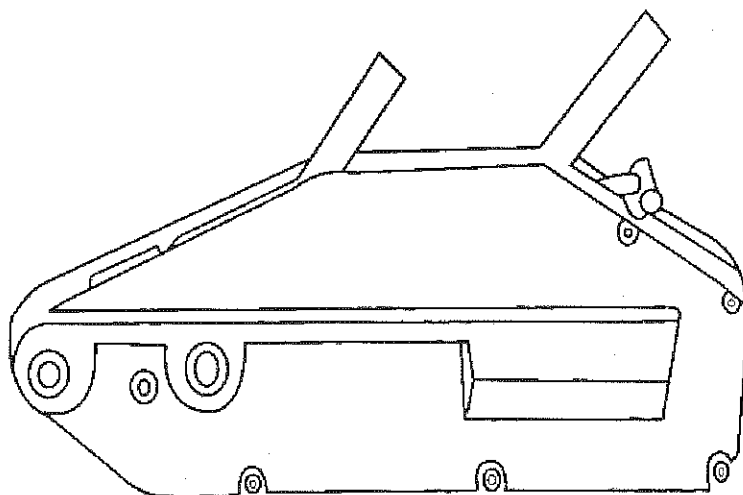

WIRE ROPE HOIST

WIRE ROPE PULLING HOIST OPERATING AND MAINTAINING MANUAL

Wire Rope Pulling Hoist, newly produced in our works, is a kind of hoist of new style and with high efficiency, safe and durable in service. It has three main prominent capacities: lifting, pulling and tensioning. Compared with other old chain-type pulling hoist, it is more widely used and more suitable in working. According to the length of the suitable rope, it can be used for linear and unlinear lifting, pulling and tensioning. With special attachments, such as fixed or movable pulley blocks, not only can it change the operating position and move the load conveniently, but also the capacity of the machine can be multiplied. To heavy duty, several machines can be used in parallel.

Wire Rope Pulling Hoist is quite different from other hoists. Being technically designed, its prominent properties areas its case is moulded with aluminium, it is fine in appearance, durable in service and of the advantage of high safe coefficient; as its core axle (for grip jaws) is properly designed, well-made and electroplated with zinc, it has a longer operating life; as its suitable rope is made of a kind of high- quality steel rope, it has the property of higher pulling force, unbroken and less rope wear. Thus Our machines are highly praised by the users, both at home and abroad. Read the manual first, and then you, our old and new users, will be able to use them conveniently and fulfil your work safely and perfectly.

I. Scope of Applications

The machines are widely used in the following:

In factories: To install or translocate apparatus.

In mines: To structure or recover pit props.

On Construction Sites: To work on the walls of high buildings in a floating crane without any scaffoldings.

In railway building: To adjust or remove rails, to dig tunnels or culverts.

In building bridges: To lay bridge frames or maintain bridge piers.

In irrigation construction: To install or maintain irrigation projects.

In electric power construction: To install or erect towers, or to tension power cables.

In transportation: To load or unload heavy bulky goods, to be out of danger for vehicles in the fields, to save vehicles or to remove obstacles on the road.

In navigation: Always used as attachments on ships.

In agriculture: To remove obstacles from the farm machinery, and to save living stocks in special conditions.

In forestry: in falling trees, use the machine to pull down the trees.

In military engineering: To translocate the cannons to the shade, to build the

temporary simple suspension bridges or floating bridges or to install other military engineering projects.

For civilian purpose: To lift or lower any house-hold articles in high buildings or to clean the old civilian houses.

In city construction: To lay water pipes, to install light apparatus, or to erect electric poles, etc.

Along with the increase of the knowledge of the features and the principles of our product, you will operate it in wider applications.

2. Principle of Work

Wire Rope Pulling Hoist is operated by acting the forward handle or the backward handle manually so as to obtain the rectilinear pulling force equal to the load through lever principle with less manual force and so as to perform the work of lifting, pulling and tensioning.

Pulling the forward handle or the backward handle back and forward, drive the Parallelogram clamping mechanism of the front and back jaw-blocks inside the machine to make "Clamping-related" moving alternately. Then the wire rope between the upper grip jaw and the lower grip jaw forms an "R" mouth. The clamping state still remains in it because of the action of the pretension spring. Thanks to the friction on the interface and the pulling force of the load, the frame of parallelogram clamping mechanism always inclines backward in the direction of the load and intends to clamp the rope a step farther. By the aid of the other connecting levers, the front and the back jaw blocks make themselves clamp the stressed wire rope and thus travel and slip to another pair of upper and lower grip jaws and cause the load to lift or lower.

Compared with other old model iron-case hoists, our machine has a completely different structure design, and its advantages display as following:

Its independent pretension spring works well alternately and makes the travel shorter, the mechanical rate higher and the wire rope less wear.

The grip jaw, made of alloy steel and heat-treatment, has a reliable and durable clamping force and can operate well continually.

As the structure inside the machine is properly designed, the machine has the excellent property in working and maintaining.

When the load is over-Loaded or the pulling is excess, the safety pin on the forward handle will break simultaneously and so the machine can be well protected.

3. Operating Method

3.1 Rope reeving: Hold the machine in one hand, with its head downward, and push the released handle. After hearing a noise click, the grip jaws open and the clean wire rope can be reeved to a desired length. Having finished it, push the released handle downward by hand to allow grip jaws to clamp the rope. When pulling the forward handle back and forward, the rope inlet or outlet shows that the unit works normally. Then start operation.

3.2 Anchoring: Fixed axis is to be used to anchor the rope around it. The other tip of the rope is tied to load. After the fixed axis is inserted into the machine case, it must be turned twice. Start operation until the second tunnel is obstructed. Let the rope tip expose above the fixed axis, so as to ensure the rope to travel normally.

3.3 Operating : Let a hook hook the load and operate as following:

To lift a load(or push a load forward) or tension it: Push the forward handle.

To lower a load(or pull a load backward): Pull the backward handle.

To stop working: Not to pull the handle will stop the load at arbitrary position, whether lifting or lowering it.

3.4 Drawing rope: After finishing work, firstly push the released handle, then open the grip jaws and draw the rope out. Erase the dirt on the rope and wind it orderly on to the reel cross.

Press down the released handle so as not to keep the grip jaws always in an open state, thus to reduce the spring force of the tensioning spring.

4. Precauti0ns in Use and Maintenance

4.1 Before use, you must inspect all the tightened screws and see if they are secured. Pull all the handles and see if they are in order. If operating coordinatively and without unusual noise or blocking, act released handle, reeve the clean and suitable rope. Don't let the twisting, cracked and part-broken rope in. In the end, operate handles again and see if the machine can travel normally.

4.2 Never do such things during operating:

Never pull other handles at the same time. Never pull released hankle after the load is lifted.

Never use other self-made extended lever tube to save handpower.

Never pull the handle violently to break the safety pin. If this happens, the replacements must be provided by our factory only.

Never stand on the load or beside it when operating(except working on a floating-crane).

Never use the rope itself as a loop around the load. The load must be hung on a hook.

When lifting a load, never let the load floating around in the air.

Ensure that the rope inlet and Outlet is not obstructed, when the unit works. Jamming, gagging and twisting must be prevented Erase the mud or dirt on the rope.

4.3 When the original rope dlameter of the working length reduces by 10%, it must be replaced with a new one provided by our factory only. The old one maybe for other purposes. The mixed use of various wire rope is not allowed.

4.4 To make parts by yourself or to remachline and reuse the jaws are in protlibitted The replacements must be provide by our factory only. After replacing prperly. a test of 1.25 times of rated capacity must be made. Resume the operation only when the test-travel is no less than 500mm.

4.5 Never reeve the rope from the head of the machine. Our machine only allows the rope tip in the tail to support the load. The direction of the hook must not be used reversely. All these are very dangerous and will cause the machine to work abnormally.

4.6 The anchored object should have enough power to support the load and will not cause an accident

4.7 When the machine is tied to lift a floating crane, the total load should decrease 1/3 of the pulling force as the machine has. Besides the worker operating on the crane must be safely protected.

4.8 If muddy water or other dirt has penetrated into the machine, use clean water to clean it. Disassemble the body to rinse once more if necessary. Reassemble the body carefully and properly, and then lubricate it with calcium base grease. Maintenance must be made 2 times every year in ordinary condition.

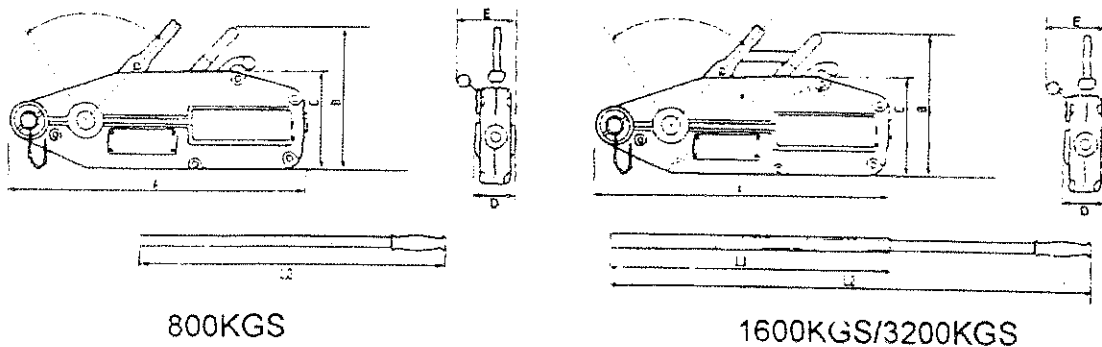

Item No.	0.8T	1.6T	3.2T	
Rated Capacity (kg)	800	1600	3200	
Rated Forward Handpower (N)	343	441	441	
Rated Forward Travel (mm)	≥ 52	≥ 55	≥ 28	
Rope Diameter (mm)	8.3	11	16	
Wire Rope Safety Factor Load Capacity	5	5	5	
Safety Factor & Static Load Capacity	5	5	5	
Max. Travelling Load (kg)	1200	2400	4000	
Max Overall Size (mm)	A	426	545	660
	B	235	280	325
	C	168	190	230
	D	60	72	91
	E	64	97	116
L1 (cm)		80	80	
L2 (cm)	80	120	120	

Parts Name

1. Left side plate
2. Right side plate
3. Handle
4. Rivet
5. Hex - bolt
6. Spring washer
7. Hex - Bolt
8. Hex - Nut
9. Front Jaw Block
10. Back Jaw Block
11. Relaxed connecting rod axle
12. Backward handle
13. Released handle
14. Fixed axle
15. Saefty pin
16. Upper grip jaw
17. Connecting rod
18. 2nd pin
19. 3rd pin
20. 4th pin
21. Washer
22. Washer
23. Shake rod
24. 5th pin
25. Connecting rod
26. Crank axle
27. Stay pin
28. Guide tube of wire rope
29. Tube handle
30. Bearing
31. Forward Handle

800KG

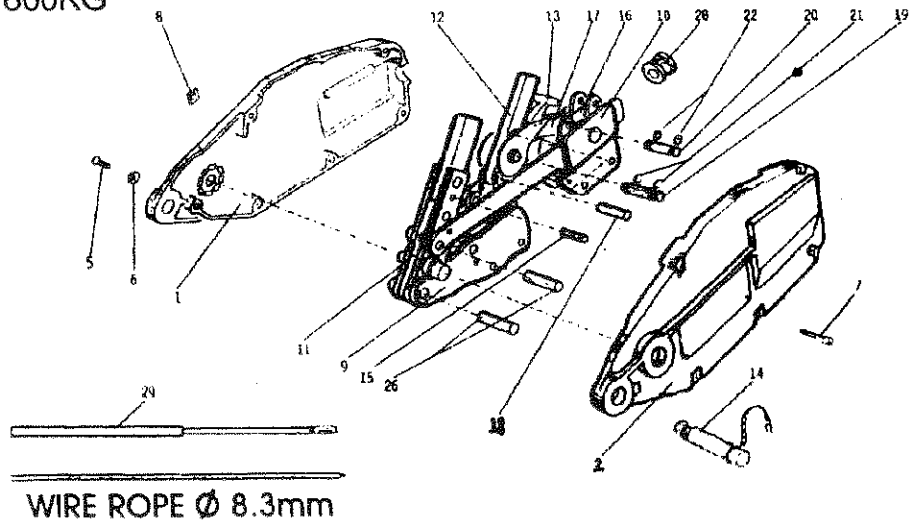

1600KG

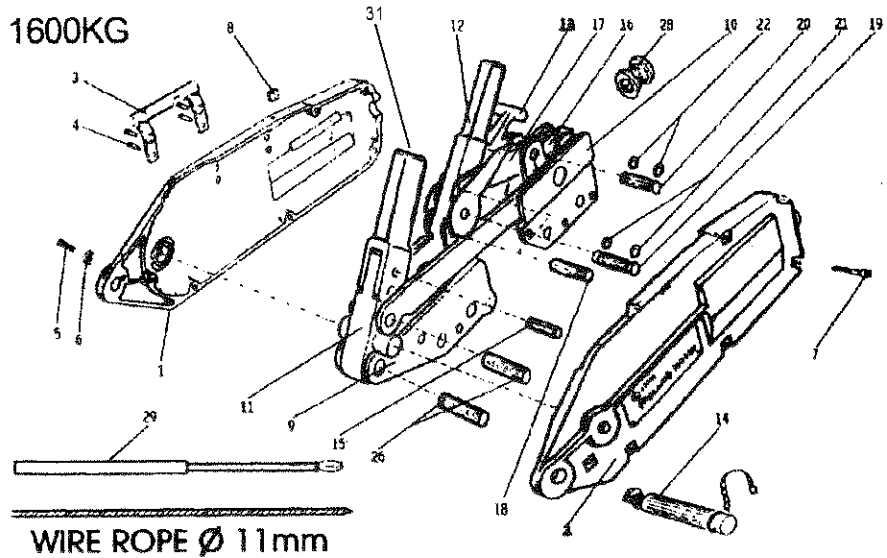

3200KG

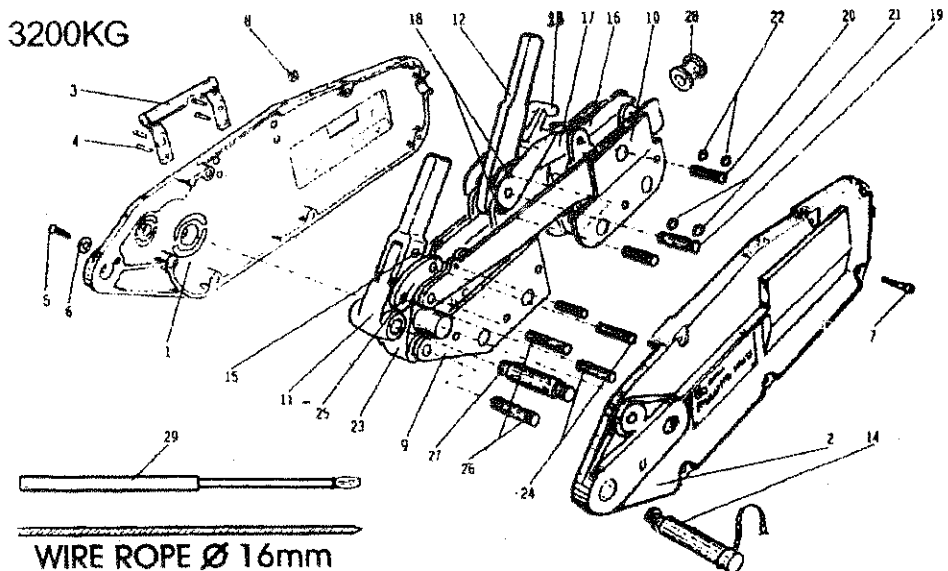

Item No.	5.4T	
Rated Capacity(kg)	5400	
Rated Forward Item No. power(N)	745	
Rated Forward Travel(mm)	≥30	
Rope Diameter(mm)	20	
Wire Rope Safety Factor Load Capacity	5	
Safety Factor & Static Load Capacity	5	
Mac. Travelling Load(kg)	8000	
Max. Mac Overall Size(mm)	A	932
	B	420
	C	300
	D	155
	E	152
Max	L1 (cm)	72
	L2 (cm)	120

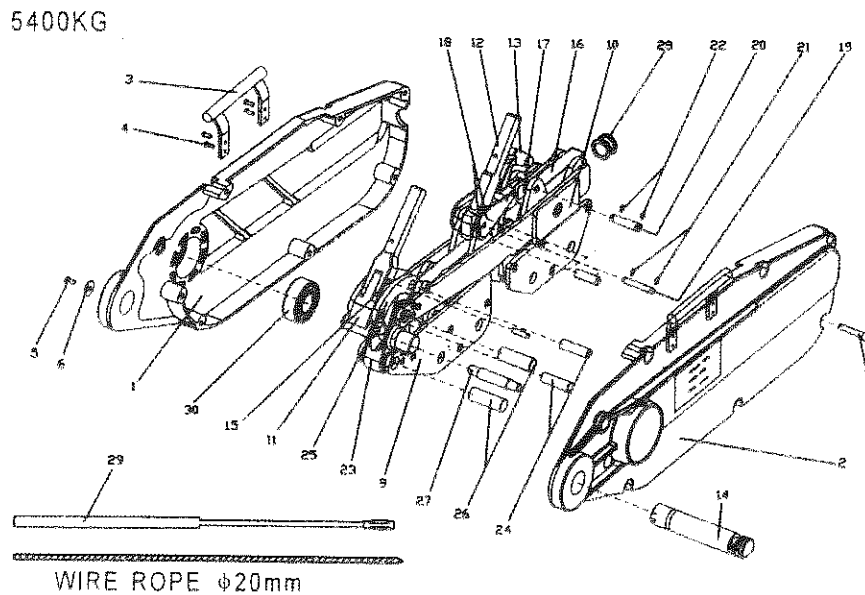

Parts Name

- | | | |
|---------------------------------|-----------------------------|--------------------|
| 1. Left side plate | 15. Saefy pin | 29. Tube handle |
| 2. Right side plate | 16. Upper grip jaw | 30. Bearing |
| 3. Handle | 17. Connecting rod | 31. Forward Handle |
| 4. Rivet | 18. 2nd pin | |
| 5. Hex - bolt | 19. 3rd pin | |
| 6. Spring washer | 20. 4th pin | |
| 7. Hex - Bolt | 21. Washer | |
| 8. Hex - Nut | 22. Washer | |
| 9. Front Jaw Block | 23. Shake rod | |
| 10. Back Jaw Block | 24. 5th pin | |
| 11. Relaxed connecting rod axle | 25. Connecting rod | |
| 12. Backward handle | 26. Crank axle | |
| 13. Released handle | 27. Stay pin | |
| 14. Fixed axle | 28. Guide tube of wire rope | |