

» Light Weight & Easy Handling

SKC150(M) • SKC250(W) • SKC1250D

LIFTING CLAMP FOR CONCRETE MATERIAL  
(Manual / Machine Type)

CHECK!



Operation manual & parts drawing

Example of use

⚠ Always lift a load at 2 or more points for safety.

Manual type

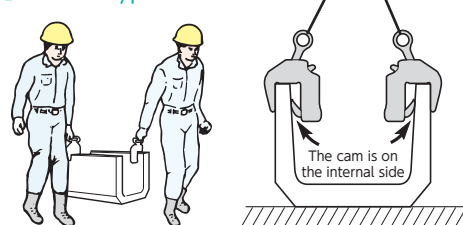

Machine type

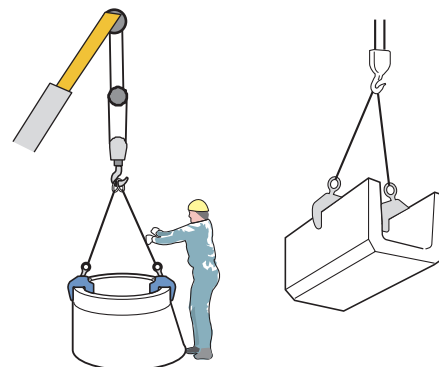

\* SKC1250D (deep wide type) shows its great power especially for lifting assembly sewage manhole.

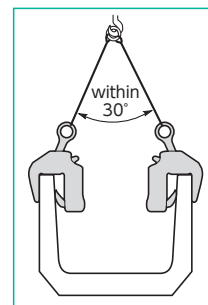

Features

- Ideal for lifting and handling concrete materials like reinforced concrete U shaped gutters, single side thick U shaped gutters, U flumes.
- Compact, light-weight and easy to handle.
- Including a mechanism making that the clamping force increases in proportion to the load weight.
- One touch open/close mechanism for easy operation.

Cam types, pad types

Manual, machine types

Adjustable clamp range types, balances

Internal expanding lifting clamps for U shaped gutter

Batch lifting clamps for bank block

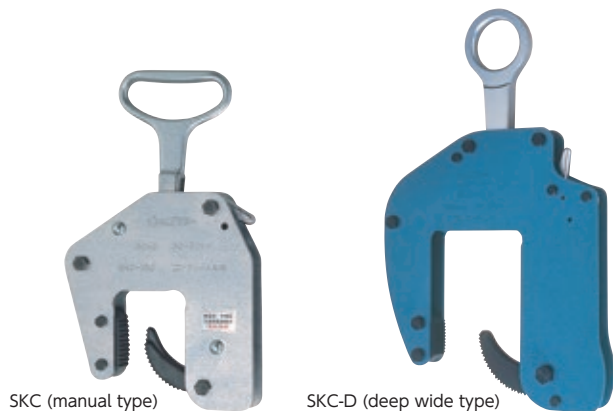

SKC (manual type)

SKC-D (deep wide type)

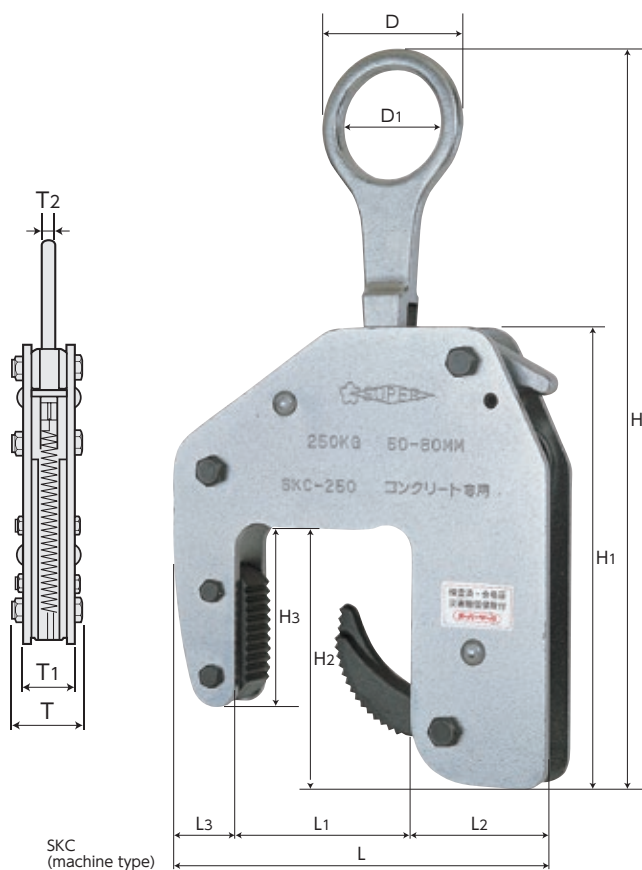

SKC (machine type)

Item No.	Item type	Rated capacity (lb)	Clamp range (in)	Size (in)											N.W. (lb)		
				L	L1	L2	L3	H	H1	H2	H3	D	D1	T		T1	T2
SKC150	Manual type	330.69	1.18~2.36	7.28	2.56	2.56	2.17	10.16~12.28	7.87	4.25	3.27	4.41	—	1.75	1.22	0.63	6.61
SKC150M	Machine type	330.69	1.18~2.36	7.28	2.56	2.56	2.17	10.79~12.91	7.87	4.25	3.27	2.76	1.97	1.75	1.22	0.39	6.61
SKC250	Machine type	551.16	1.97~3.15	7.48	3.35	2.60	1.54	10.94~13.07	8.07	4.41	3.35	2.76	1.97	1.75	1.26	0.39	6.61
SKC250W	Machine type	551.16	2.76~3.94	8.27	4.13	2.60	1.54	10.94~13.07	8.07	4.41	3.35	2.76	1.97	1.75	1.26	0.39	7.72
SKC1250D	Deep wide type	2755.78	2.87~5.39	13.98	5.71	4.92	3.15	18.78~21.97	15.16	9.55	7.58	3.94	2.76	2.38	1.46	0.71	22.05