

SAFETY LIFTING CLAMPS

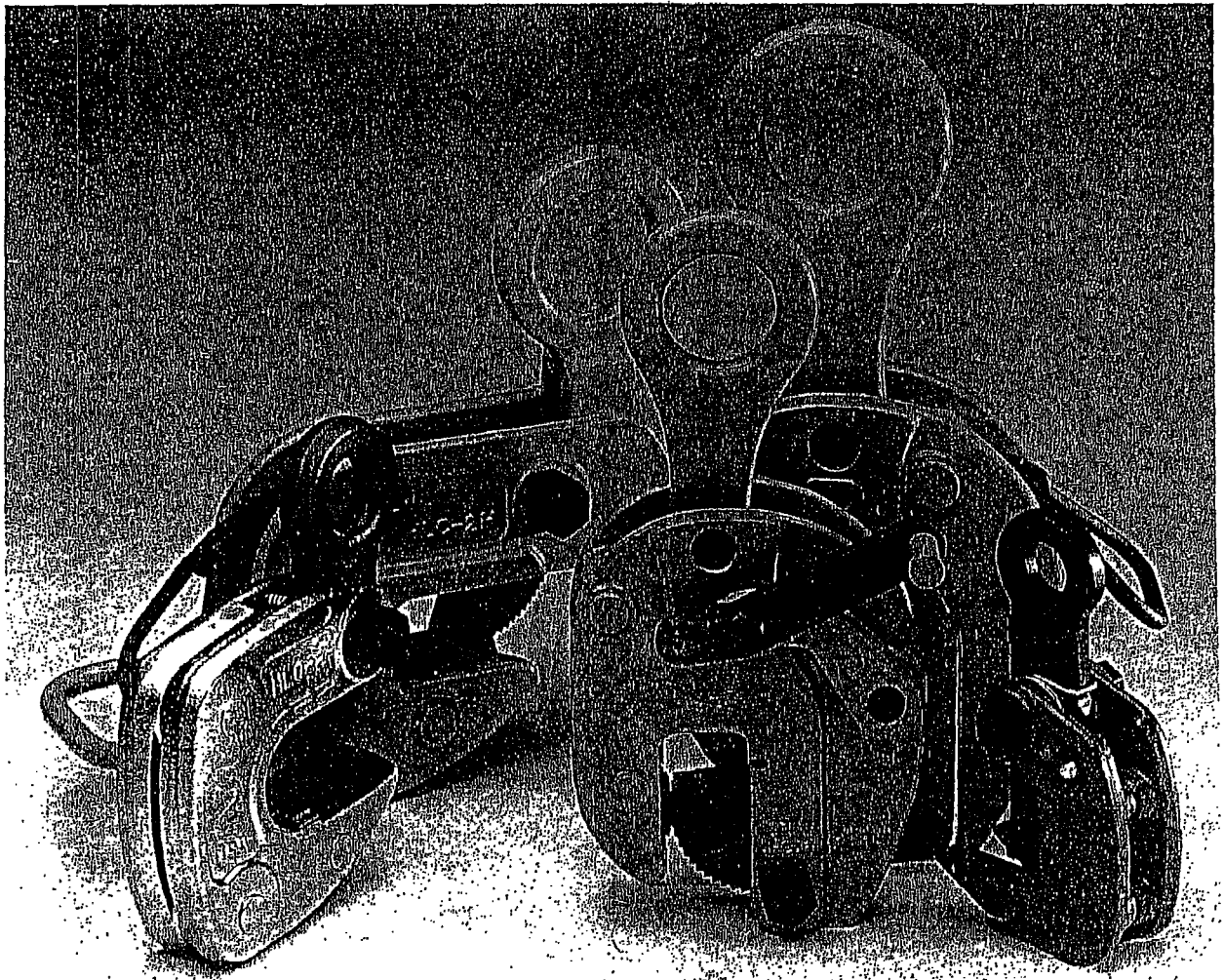

INSTRUCTION FOR OPERATION
OF
"SUPER" BRAND
LIFTING CLAMPS

PTC 100 PTC 200
PSC 100 PTC 250
PTC 150



SUPER TOOL CO., LTD.

OSAKA, JAPAN

On the Proper Handling of Lifting Clamps with Super Tool's Mark

We are thankful to you for your selection and purchase of our Lifting Clamps with Super Tool's mark on them. Our Lifting Clamps with Super Tool's mark on them (hereinafter to be called "Lifting Clamp" or "Clamp") is energy-saving lifting tools designed and developed for transportation of panel and beams.

Proper use of Lifting Clamps demanded

You are kindly asked to operate the Lifting Clamps after careful reading and understanding of this instruction manual for the purpose of enhancing safety and efficiency at work.

Prime efficiency and economy

The sophisticated functions, reasonableness and wide applications of the finely and carefully designed Lifting Clamps ensure prime efficiency and economy.

Special care of safety

We have executed tensile tests with loads three times (or twice) the rated capacity according to the testing standards set forth by the National Institute of Industrial Safety of Ministry of Labor and attached inspection numbers to individual products, thus directing special attention to the aspect of safety.

Attachment of products and completed operation liability insurance

If there occur damages due to the defective qualities of the Lifting Clamps under the normal conditions of use, insurance money under the products and completed operation liability insurance will be paid for them. If the damages are, however, incurred due to intentional misbehavior or mistaken use (non-safety actions), abrasion of the clamp pads, they are not covered. Be careful. Never fail to post before use the application for registration for products and completed operation liability insurance attached with the clamp (return post card) after filling in all the required items of information.

Cautions for safety operation

Please do not fail to carefully read this instruction manual before use of the Lifting Clamps. Mistaken use of the Lifting Clamps (hereinafter to be called "Clamps") may cause troubles such as the dropping of lifted work.

Please never fail to carefully read this manual for proper operation before use.

Education of "crane safety regulations," "operation manual for lifting clamps," "in-house operation standards," etc. is to be given before actual operation not only to business owners who have purchased the Clamps but also to their operators to ensure that actual operators will have acquired enough knowledge of clamps, safety information, and cautions.

As according to the "Lifting clamp safety council," we have divided cautions in general into "Dangers" and "Cautions," which are used in this instruction manual.

◇DANGER: Indicates mistaken handling may cause a potentially hazardous situation which, if not avoided, could result in death or serious injury.

△CAUTION: Indicates mistaken handling may cause a potentially hazardous situation which, if not avoided, could result in medium damage or slight injury, or could result in property damage.

Even though only mentioned in the Cautions, those incidents may lead to a serious disaster. So, do not fail to pay attention both to dangers and cautions which are of great importance in

operating the Clamps properly.

Meanings of Signs

The signs of ◊ and △ indicate that attention is to be given to the marks indicative of dangers and cautions respectively. The signs figuratively show the contents of danger or caution. (The left-side sign indicates a caution to the pinching.)

The sign indicates prohibited actions.

The sign of ○ indicates that an action is enforced or instructed to be executed. Inside the sign or beside it is shown a concrete instruction is described. (The left-side sign requires a lifting at two points.)

* After reading of this manual, please keep it at a convenient place to which any user can gain easy access for reference.

1. About handling in general

Dangers	
<ul style="list-style-type: none"> ● Any person who is not well-informed about instruction manual, tags, and signs of cautions is not eligible for use of the Lifting Clamps. ● Any person who is not legally qualified is never to operate a crane and a lifting clamp. (Clauses 221 and 222, Crane Safety Regulations) ● While lifting or turning the work, do not enter the area where the lifted work threatens to drop off or fall over. (Clauses 28 and 29, Crane Safety Regulations) ● Do not use this lifting clamp for other purposes than lifting work. 	
<ul style="list-style-type: none"> ● Never fail to execute an inspection before use and periodical inspections. (Clauses 217 and 220, Crane Safety Regulations) 	

2. About checkings before operation

Dangers	
<ul style="list-style-type: none"> ● Do not use a clamp other than applicable to the operation method. ● Do not use an abnormal clamp with deformation, cracks, operational trouble, abrasion, etc. ● If the work to lift is under the following conditions, do not apply the clamp. (fragile material, high-hardness material, low-hardness or extremely low-hardness material, and members with the gripping part of no pitchedness and of more than 10 degrees in temperature of itself) 	
<ul style="list-style-type: none"> ● Please check on the clamp main unit the type, basically applicable load, opening diameter, and indication of periodical inspections executed. ● The load of the work to lift shall be within the allowable range of the basically applicable load of the clamp. ● The thickness of the work to lift shall be within the allowable clamping range. 	
Cautions	
<ul style="list-style-type: none"> ● Do not use the clamp with tags and signs of cautions attached to it taken away, and with them kept invisible. ● Do not use the clamp for the work under the following conditions. (The work to lift is more than 150 degrees, is less than minus 20 degrees in temperature, and acidic or alkaline chemicals.) 	
<ul style="list-style-type: none"> ● The sling to be used for the clamp shall be an appropriate one for the lifting operation. 	

3. About the method of use and lifting operation

◇Dangers	
<ul style="list-style-type: none"> ●Do not use the Clamp, lifting at one point. ●Do not use the Clamp in the following way of lifting: (overlapped works, padded work, engrafted lifting, concurrent lifting, and side gripping) ●Do not use the Clamp for pulling out from among steel sheet pilings and not lift pulled-out steel sheets vertically. ●Do not use the Clamp when strong wind threatens to cause any danger. ●Do not use the Clamp for a hydraulic excavator. 	
<ul style="list-style-type: none"> ●Install two or more Clamps in a balanced way to keep the work' balance. 	
<ul style="list-style-type: none"> ●The lifting angle of the Clamp and the dividing angle are to be kept within the allowable angles according to types. ●The work is to be inserted to the innermost end of the Clamp opening. ●When you use the Clamp with a locking system, never fail to use the Clamp with the locking system on. 	
△Cautions	
<ul style="list-style-type: none"> ●If oil, paint, scales, rust, etc. are on the gripping pad, do not use the Clamp. ●Do not drop to the ground or drag along the ground the Clamp. 	

About the operation of a crane

◇Dangers	
<ul style="list-style-type: none"> ●Never lift the work weighing more than the basic working load. ●Do not operate the crane in such a way as to give an impacting load to the work or the Clamp. ●Do not allow a man to stand on the lifted work. Never use the Clamp for the purpose of carrying a man. ●Do not lift the earth itself. ●In the course of lifting the work, do not release the lock of the Clamp. ●Do not let the Clamp removed from the work collide with the work or an adjacent member. ●When you wind up the wire by the crane and notice the load at the lifting ring, stop the operation temporarily for safety checking (depth of the work into the Clamp opening; status of locking). ●Stop the operation of the crane just before the work reaches the ground, check the following items of things: (Slant and falling over of the work; security at the landing site and its surrounding) 	
<ul style="list-style-type: none"> ●When you wind up the wire by the crane and notice the load at the lifting ring, stop the operation temporarily for safety checking (depth of the work into the Clamp opening; status of locking). ●Stop the operation of the crane just before the work reaches the ground, check the following items of things: (Slant and falling over of the work; security at the landing site and its surrounding) 	
△Cautions	
<ul style="list-style-type: none"> ●Do not operate the crane in such a way as to drag the work along the ground. ●Do not step away from the crane (winder, etc.) operating position while keeping the work being lifted with the Clamp. 	
<ul style="list-style-type: none"> ●Hoisting and lowering operation by the crane are to be made slowly and carefully. 	

About maintenance, storage and remodeling

◇Dangers	
<ul style="list-style-type: none"> ●Never execute any remodeling of the Clamp and its accessories. ●Do not apply welding work or heating to the Clamp and its accessories. ●Do not use any other parts than our company's brand-name parts. ●Store at a different place Clamps requiring repairing not to be used mistakenly. 	
<ul style="list-style-type: none"> ●A person with specialized knowledge specified by the business owner is to conduct maintenance and repairing work. ●When you detect abnormality with the Clamp, do not use it and immediately repair or dispose of it. ●Remove, if any, paint or mud sticking to the moving parts of the Clamp, cams, and pads. 	
△Cautions	
<ul style="list-style-type: none"> ●Conduct maintenance and repairing with no work lifted. ●Conduct maintenance and repairing after posting a sign indicating that you're working on the maintenance work. ●Never fail to put lubricating oil on the rotating part of the Clamp (around the pin), guide groove, sliding parts, etc. ●Store Clamps inside a room. 	

Note: Please contact our company's sales agents or sales offices to make advantage of our services in respect with items of inspections and maintenance standards accompanying disassembly and assembly.

■ Applications

Optimal for lifting and movement of and execution work for panels for housing.

Product No.	Applications
PTC 100 PSC 100	This Unit is optimal for lifting and movement of and execution work for siding boards, external-wall panels, mold forms, insulating external-wall materials, wooden panels, etc. This Unit is not intended for panels which do not have reinforcement materials such as reinforcing steel bars and are susceptible to collapse.
PTC 150 PTC 200	This Unit is optimal for lifting and movement of and execution work for panels for two-by-four construction method and beams for wooden housing.
PTC 250	This Unit is optimal for lifting and movement of and execution work for panels for two-by-four and two-by-six construction method and beams for wooden housing.

* Do not use this Unit for lifting ALC panels and extrusion boards.

In addition, this Unit is not intended for various types of concrete products, tile plates, glass sheets, stone sheets, metal plates, etc.

■ Features

1. The Units are compact and light, and so are easy to use.
2. In proportion to lifting load, fastening strength will increase, clamping the work securely.
3. The clamping range is wide, and it is adjustable with an adjustment plate pin.
4. Because of the spikes attached on the movable pads (panel-clamped part), there occurs no slipping between the panel and the clamp, ensuring safety execution.
5. Polyurethane rubber is used for the fixed pad, so the front side of the panel is not susceptible to bruise.
6. Working efficiency can be enhanced as the fastening lock can be unlocked by remote operation.

■ Specifications

Product No.	Capacity	Clamping range	Product weight
PTC 100	100kg	5-staged adjustment type (1) 5 to 20mm (2) 20 to 35mm (3) 35 to 50mm (4) 50 to 65mm (5) 65 to 80mm	1.8kg
PSC 100	100kg	2-staged adjustment type (1) 0 to 20mm (2) 20 to 40mm	3.5kg
PTC 150	150kg	4-staged adjustment type (1) 60 to 80mm (2) 80 to 100mm (3) 100 to 120mm (4) 120 to 140mm	3.6kg

PTC 200	200kg	5-staged adjustment type (1) 35 to 55mm (2) 55 to 75mm (3) 75 to 95mm (4) 95 to 115mm (5) 115 to 135mm	4.0kg
PTC 250	250kg	5-staged adjustment type (1) 80 to 100mm (2) 100 to 120mm (3) 120 to 140mm (4) 140 to 160mm (5) 160 to 180mm	5.8kg

■ Component names and general dimensional drawing

● PTC 100

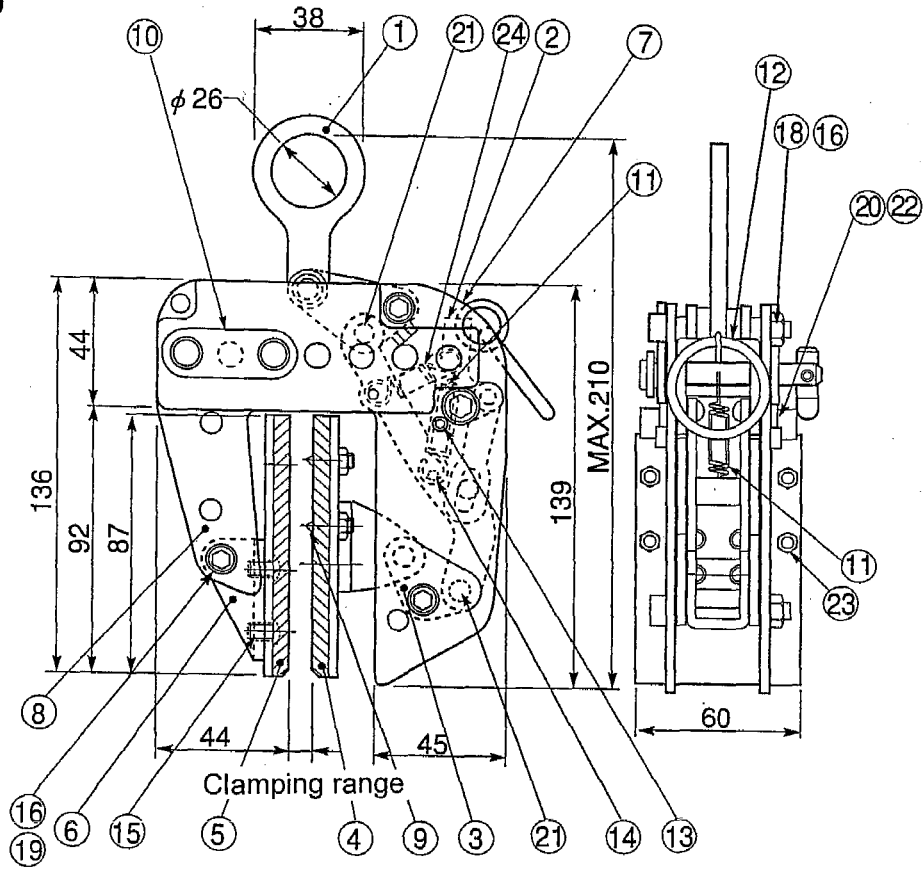

(Dimensional unit: mm)

No.	Names of parts	Quantity	No.	Names of parts	Quantity
1	Shackle	1	13	Bolt with hexagon socket	2
2	Lock lever link	1	14	Spring pin	3
3	Cam	1	15	Small round-headed screw	8
4	Movable pad	1	16	U-shaped nut	3
5	Fixed pad	1	18	Bolt with hexagon socket	2
6	Fixed-pad mounting bracket	2	19	Bolt with hexagon socket	1
7	Main unit	1	20	Bolt with hexagon socket	2
8	Arm	1	21	Pin	2
9	Spike	5	22	Spring washer	2
10	Adjustment plate pin	1	23	Hexagon nut	5
11	Spring (large)	1	24	Spring (small)	1
12	Handgrip link	1			

● PSC 100

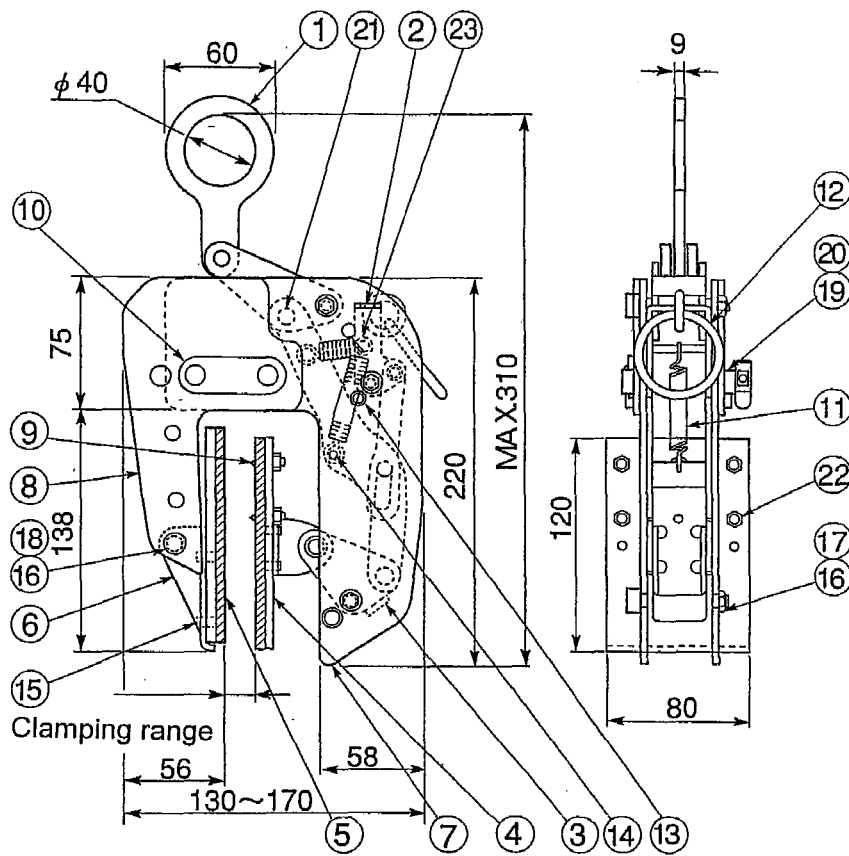

(Dimensional unit: mm)

No.	Names of parts	Quantity	No.	Names of parts	Quantity
1	Shackle	1	13	Bolt with hexagon socket	2
2	Lock lever link	1	14	Spring pin	3
3	Cam	1	15	Small round-headed screw	8
4	Movable pad	1	16	U-shaped nut	3
5	Fixed pad	1	17	Bolt with hexagon socket	2
6	Fixed-pad mounting bracket	1	18	Bolt with hexagon socket	1
7	Main unit	1	19	Bolt with hexagon socket	2
8	Arm	1	20	Spring washer	2
9	Spike	5	21	Pin	2
10	Adjustment plate pin	1	22	Hexagon nut	5
11	Spring (large)	1	23	Spring (small)	1
12	Handgrip link	1			

●PTC 200

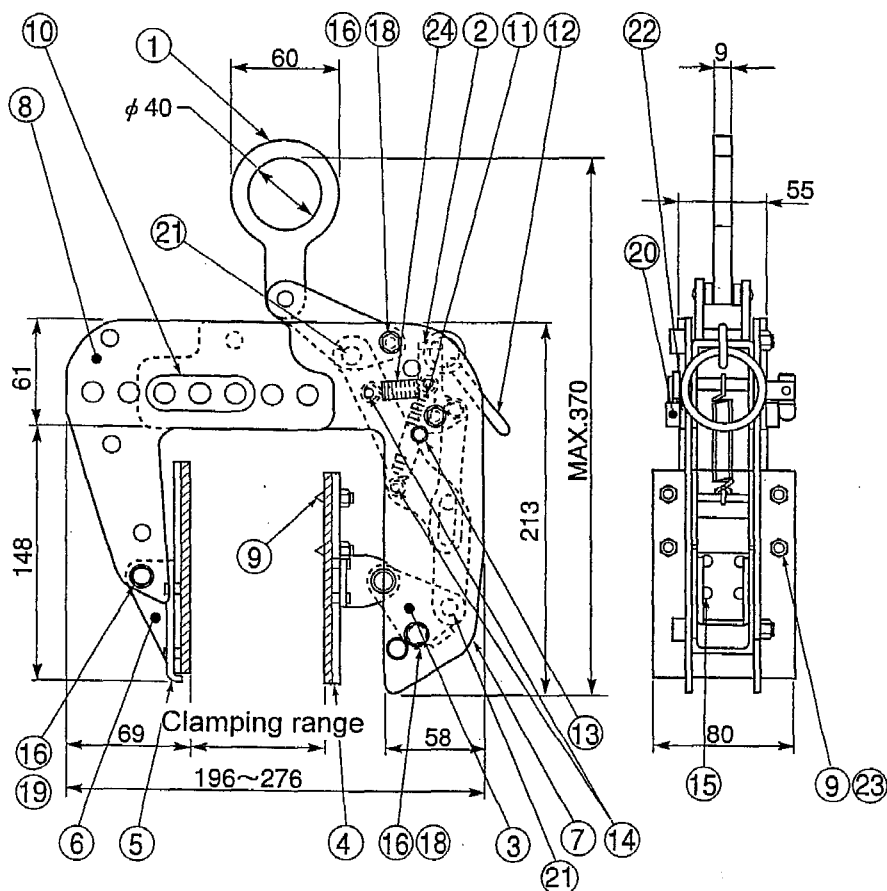

(Dimensional unit: mm)

No.	Names of parts	Quantity	No.	Names of parts	Quantity
1	Shackle	1	13	Bolt with hexagon socket	2
2	Lock lever link	1	14	Spring pin	3
3	Cam	1	15	Small round-headed screw	8
4	Movable pad	1	16	U-shaped nut	3
5	Fixed pad	1	18	Bolt with hexagon socket	2
6	Fixed-pad mounting bracket	1	19	Bolt with hexagon socket	1
7	Main unit	1	20	Bolt with hexagon socket	2
8	Arm	1	21	Pin	2
9	Spike	5	22	Spring washer	2
10	Adjustment plate pin	1	23	Hexagon nut	5
11	Spring (large)	1	24	Spring (small)	1
12	Handgrip link	1			

●PTC 250

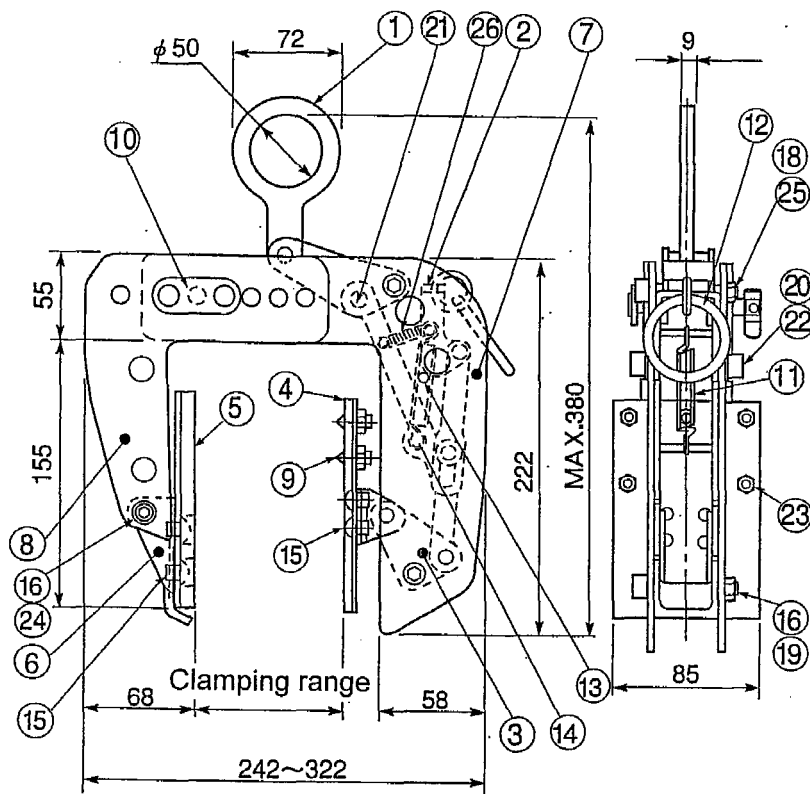

(Dimensional unit: mm)

No.	Names of parts	Quantity	No.	Names of parts	Quantity
1	Shackle	1	14	Spring pin	3
2	Lock lever link	1	15	Small round-headed screw	8
3	Cam	1	16	U-shaped nut (small)	2
4	Movable pad	1	18	Bolt with hexagon socket	1
5	Fixed pad	1	19	Bolt with hexagon socket	1
6	Fixed-pad mounting bracket	1	20	Bolt with hexagon socket	2
7	Main unit	1	21	Pin	2
8	Arm	1	22	Spring washer	2
9	Spike	5	23	Hexagon nut	5
10	Adjustment plate pin	1	24	Bolt with hexagon socket	1
11	Spring (large)	1	25	U-shaped nut (large)	1
12	Handgrip link	1	26	Spring (small)	1
13	Bolt with hexagon socket	2			

Method of Use of Clamps

● Use and operate the Clamps in the following procedure.

1. Attach the remote control rope as shown in the figure on the right hand.

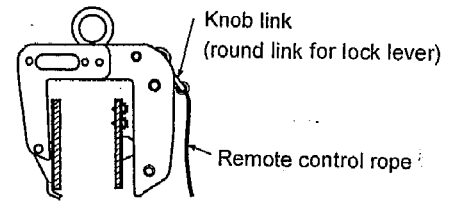

2. Adjust the clamping range according to the thickness of the panel to be clamped by changing the positions of the adjustment plate pin. Set the adjustment plate pin at the right position by selecting an appropriate one of the punch-marked indications of clamping ranges. Further, when you newly pull out and insert the adjustment plate pin, insert it all through the Unit to the end with the toggle head outside.

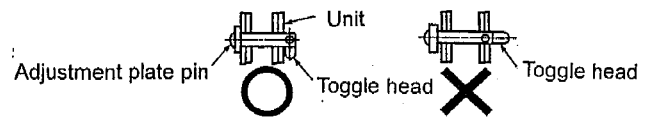

① PTC100

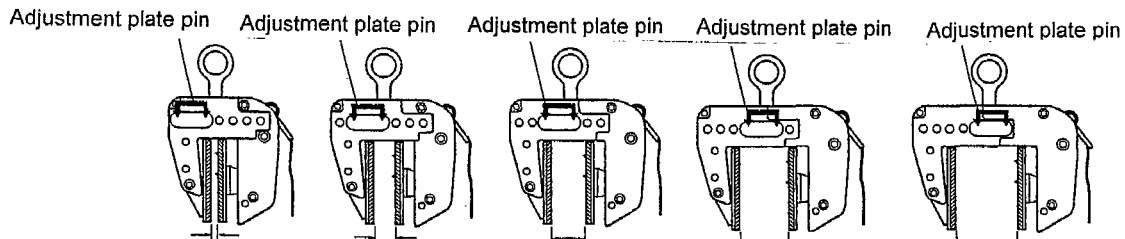

Clamping range (1) 5~20mm (2) 20~35mm (3) 35~50mm (4) 50~65mm (5) 65~80mm

② PSC 100

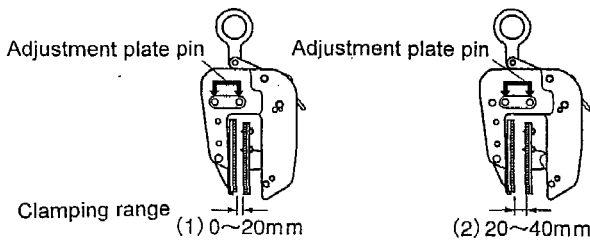

Clamping range (1) 0~20mm (2) 20~40mm

③ PTC 150

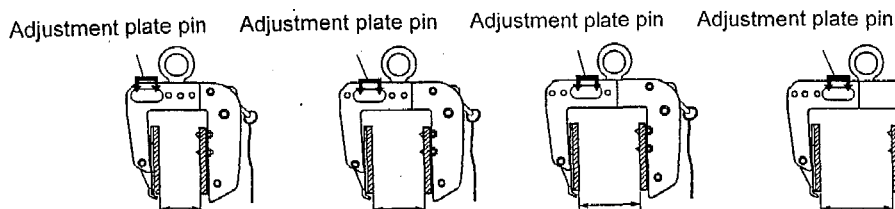

Clamping range (1) 60~80mm (2) 80~100mm (3) 100~120mm (4) 120~140mm

④ PTC 200

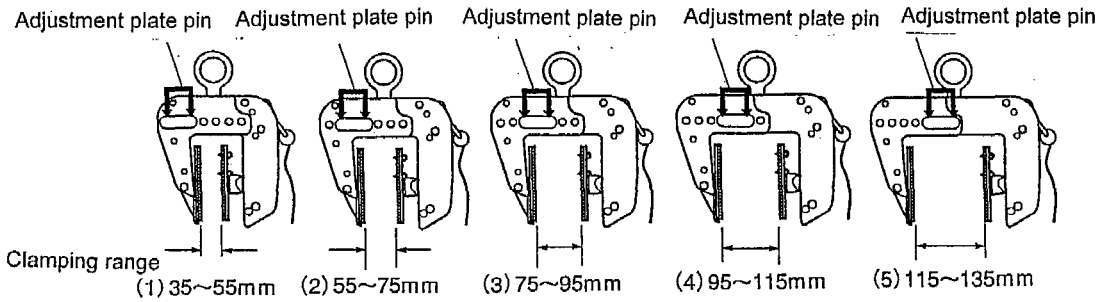

⑤ PTC 250

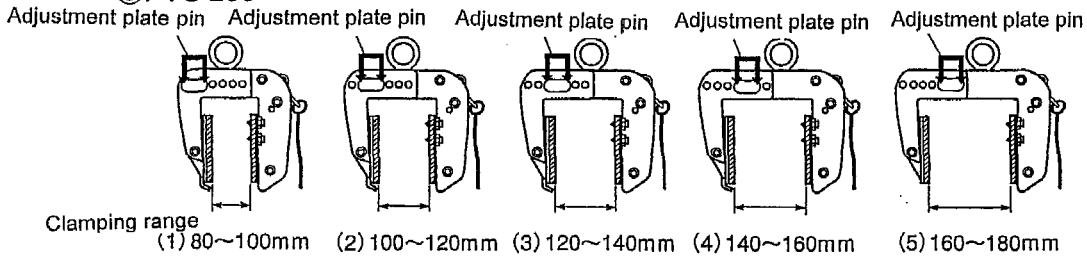

3. Lower the lock lever and confirm that the arms are opened.

4. Under the release status of the clamp, insert the work all the way up to the upper end of the opening, and then pull up the lock lever. Now you are ready to lift the work up.

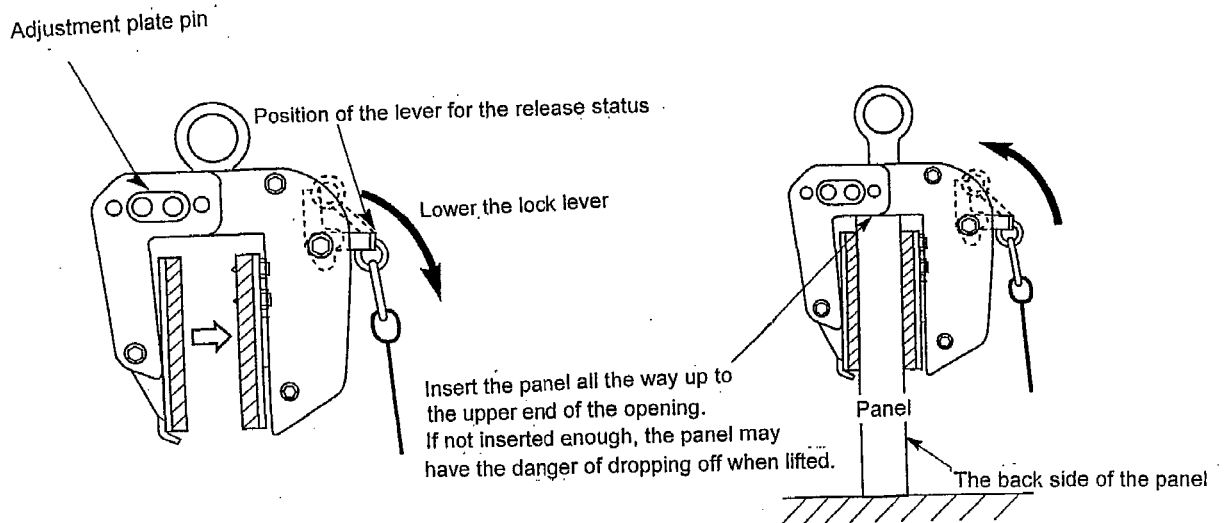

5. Confirm first that the lock lever is under the locked status, and then raise the crane and move the panel to a destination. To be more specific, use the balancer (PSB) and lift the work at two points.

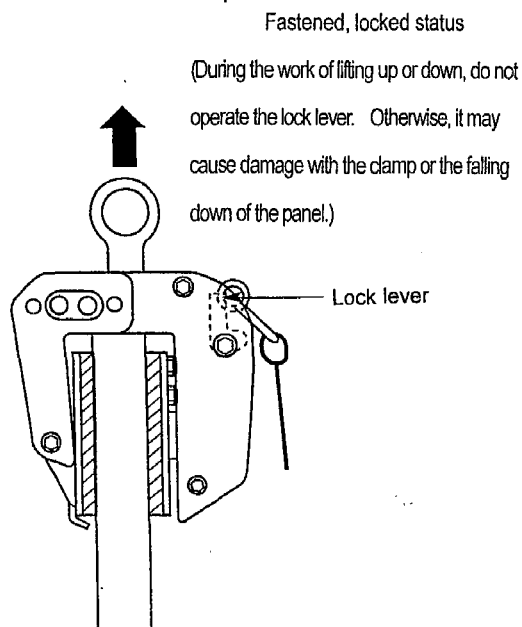

Example of the use of a balancer

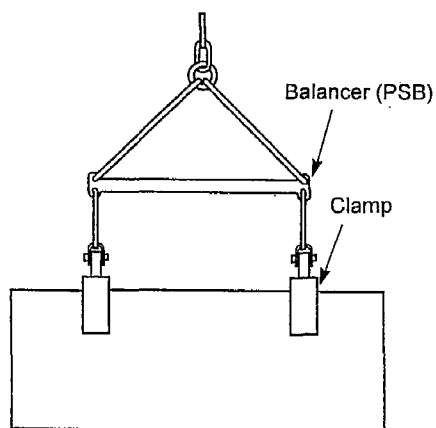

6. After moving the work to a destination, lower the crane until you have confirmed that the panel is completely on the ground.

7. When you have lowered the crane till the wire rope is loosened enough, pull down the lock lever to acquire the release status of the clamp. (If not pulled down enough, the clamp cannot be unlocked.) In addition, first make the arrangements for the panel not to fall down or drop off (for the panel to be temporarily fixed) after the panel has landed, and then loosen the wire rope and pull down the lock lever to open the clamp.

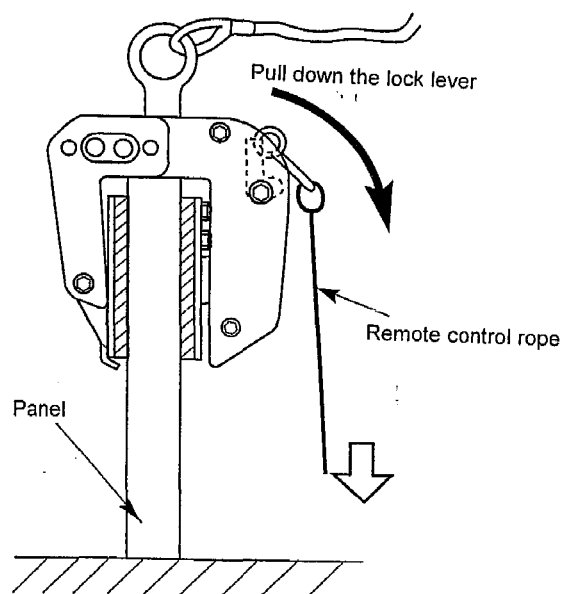

8. If you start another round of work, start with No. 3 of the procedure after confirming the clamping range and capacity required.

9. When the remote control is found impossible because of some obstacles on the back side of the panel, replace the movable pad with a fixed pad, and then clamp the panel with the front side of the panel directed toward the originally movable-pad side. If you proceed this way, you can control the operation by using the remote control rope without damaging the surface of the front side of the panel. (Refer to the figure below.) In addition, if spikes are simultaneously fixed on both of the pads, the clamping range will differ from the product feature displayed, and it will be a little harder to remove the panel from the clamp.

If the spikes are applied on the front side of the panel, their traces will remain on the surface.

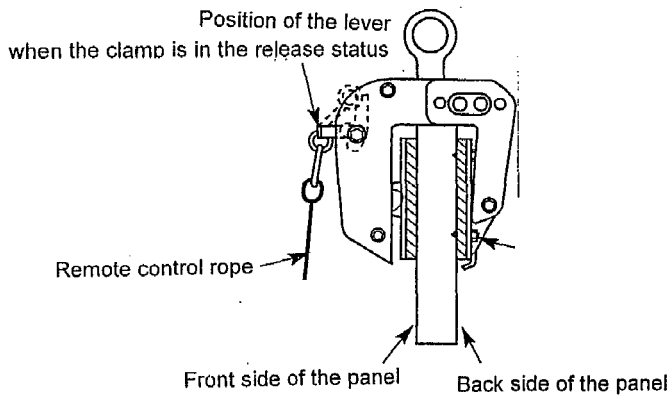

The spare holes for fixing spikes are arranged in advance for PSC 100 and PTC 150/250, so if the spikes are not effective enough to grip the panel when it is clamped, change the positions of the spikes using the spare holes as shown in the figure below.

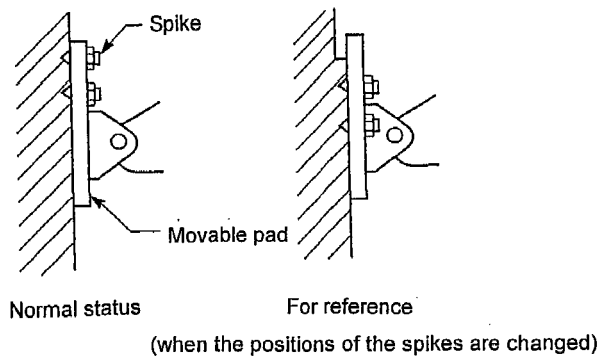

Danger

■ Cautions in handling

1. Do not enter the danger area during the lifting operation to avoid being involved in an accident caused by a falling object.
2. Do not lift the panel the thickness of which is outside of the clamping range. Never fail to set the adjustment plate pin for a required clamping range after confirming the thickness of the panel to be lifted. (Refer to Item 2 of the Method of Use of Clamps, p.14.)
3. Check for the weight of the work to be lifted and do not use the clamp beyond its capacity.
4. As regards the clamping positions, lift the gravity point, that is, the center of the work as shown in the figure below. Never fail to use the balancer (PSB) to clamp the work at two different points.

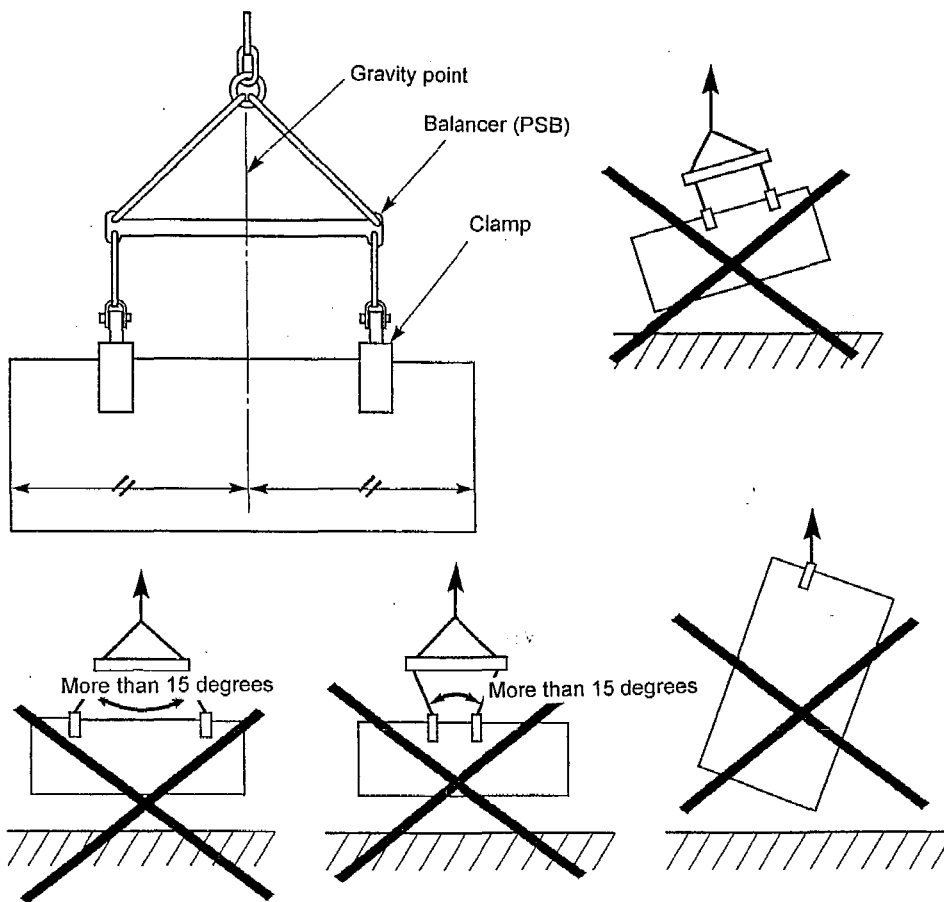

5. Do not lift piled panels at one time. Otherwise, it may cause an accident of the panels dropping off. Never fail to lift one panel at one time.

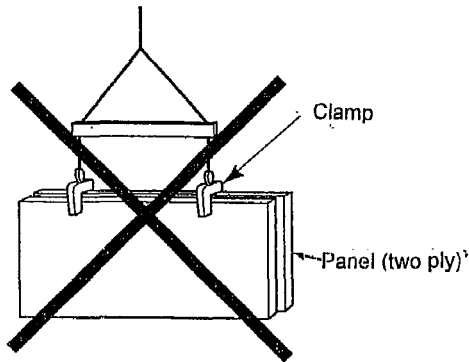

6. This clamp is dedicated for vertical lifting, not for horizontal lifting. You are strictly prohibited to clamp the panel from sides. The fastening power of the clamp will be reduced, causing a danger.

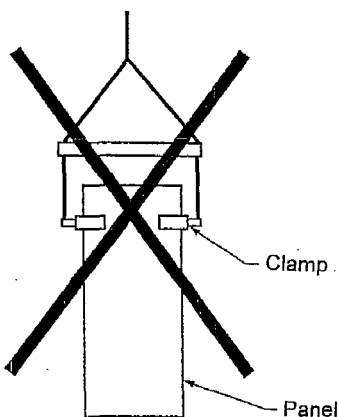
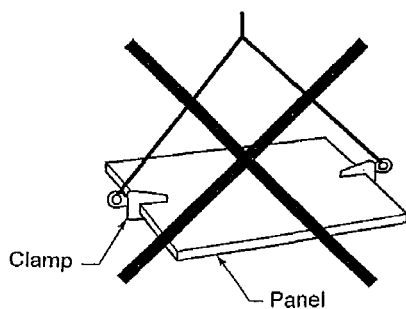

7. During the lifting operation, do not strike the clamp or the work against other objects, or get them stuck on others. (Be careful especially when lifting up or down the work.) The impact or the loosened wire rope may cause an accident of the work dropping off.

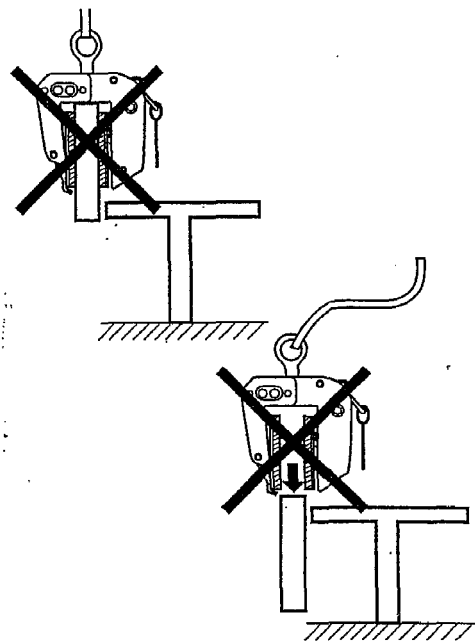

8. During the operation of lifting up or down the work, be careful enough not to get the remote control rope stuck on obstacles such as the scaffold. (The lock lever will be unlocked and the clamp will be in the release status, cause an accident of the work dropping off.)

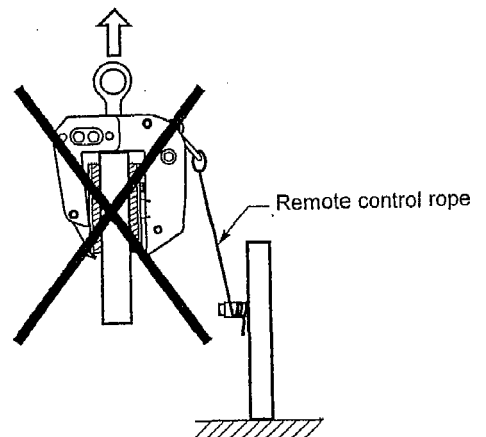

9. Do not operate the Unit with the pads or the panel attached with water, ice, snow, oil, sands, mud, etc.

10. Keep the height of the protrusion of the spikes on the movable-pad side between 1.5 and 2mm.

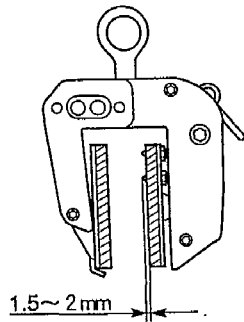

11. Never fail to check whether the panel is securely pressed by both of the pads of the clamp

PTC 100: 25mm or less
 PTC 150/250: 60mm or less
 PSC100: 50mm or less



PTC 100: 80mm or more
 PTC 150/250: 125mm or more
 PSC100: 115mm or more

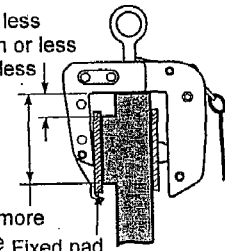

Fixed pad



In case of PTC 100

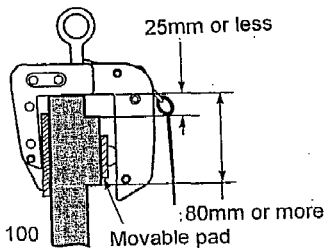

Movable pad



In case of PTC 150
 In case of PTC 200
 In case of PTC 250

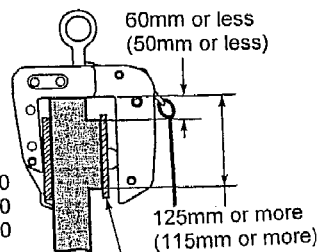

Movable pad

() for PSC 100

In addition, the following clamping statuses may cause dangers. The pads of the clamp threaten to be damaged or deformed, and an accident of the panel dropping off may be caused.

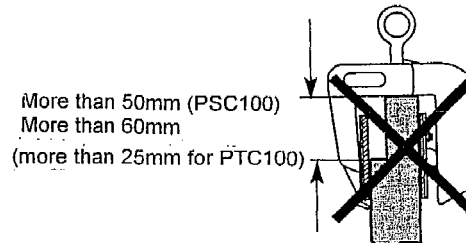
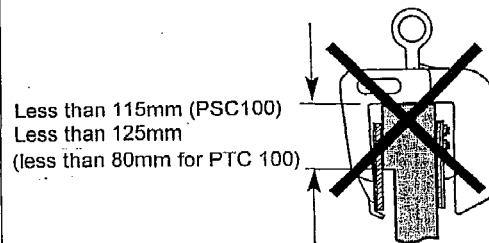
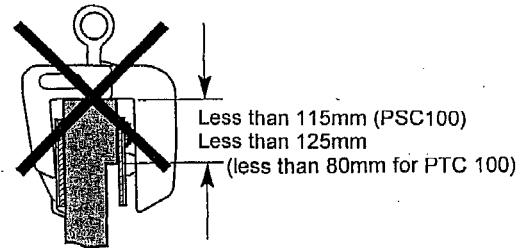
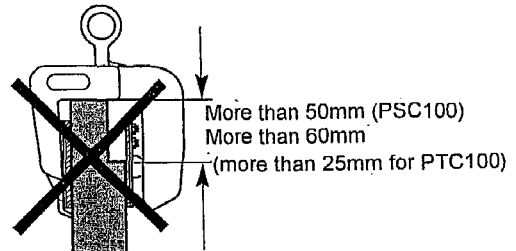
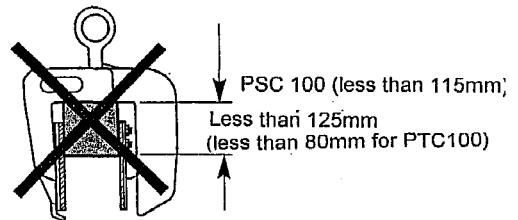

12. Do not remodel the Unit on your own accord, using gas cutting, welding, etc. Application of heat, modification, etc. may cause a significant deduction in quality (strength).

13. Put the lock lever into the locked status after having clamped the panel. And be careful enough not to catch your hand or fingers between the lock lever and the Unit.

14. When you raise the panel, clamp the panel with the lock-lever side directed upward.

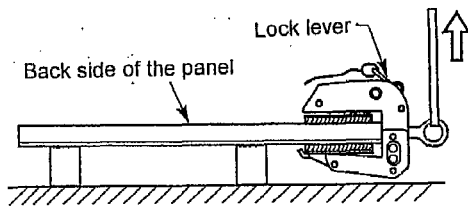

Do not pull out a panel out of the piled panels using the clamp.

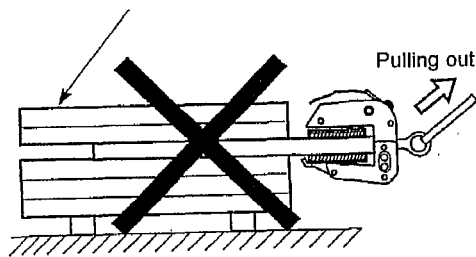

15. When you set the panel with the upper frame sandwiched by external panels, confirm that the position of the upper frame meets those of the pads of the clamp. Clamping of the part where there is no frame may cause damage with the panel or a dropping off of the panel.

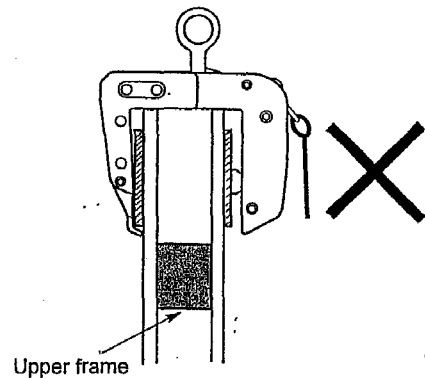

60mm or less for PSC 100
70mm or less
(25mm or less for PTC 100)

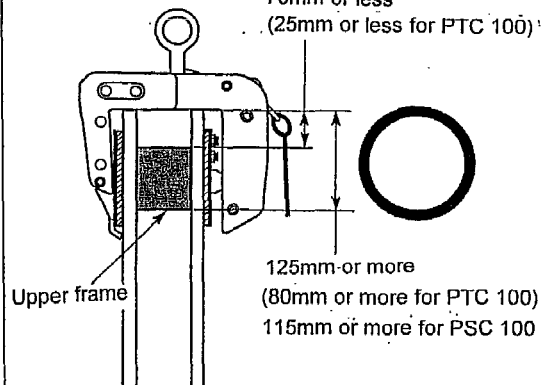

125mm or more
(80mm or more for PTC 100)
115mm or more for PSC 100

16. Do not use this Unit for the panel both sides or one side of which is a metal plate or a tile into which the spikes can not bite.

17. Execute a daily inspection for any abnormality with the operation of each component according to the inspection guideline.

Cautions

■ Maintenance and inspection of clamps

1. Method of maintaining clamps

Daily maintenance is most important for efficient safety operation of clamps even under the extreme conditions of use. Keep to the following items of maintenance work.

- (1) Maintain clamps according to the inspection standards for clamps.
- (2) Store clamps inside buildings not outside.
- (3) Make inspections of the following items and be careful in keeping clamps in the best conditions.
 - (i) Status of operation
 - (ii) Abrasion of pads and spikes
 - (iii) Deformation and distortion of the main unit
- (4) If you find out clamps which threaten to cause an accident, during operation or inspection, separate them from the good-conditioned ones for urgent repairing by indicating them as ones requiring repairing.
- (5) Never fail to receive makers' inspections.
- (6) Oil moving parts such as bolts and pins once every week. However, be careful not to put oil on the surface of the polyurethane rubber of the pad.

2. Periodical inspection

Execute periodical inspections according to the periodical inspection standards. The functions and longevity of clamps vary according to conditions of use. Therefore, you as the user are recommended to prepare your own effective handling standards or maintenance standards and to follow them. You are asked to make efforts to acquire security by all-out maintenance activities using our Super Tool's maintenance standards on lifting clamps for your reference. If an abnormality is confirmed, you are recommended to receive a maker's inspection by indicating the spot where the abnormality lies.

When preparing your own maintenance standards, be careful about the following things:

(1) Handling standards

- (i) Preparation of standards of use (according to shapes of works and methods of applications)
- (ii) Complete sharing of cautions in handling and use
- (iii) Making the checking at the site compulsory

(2) Periodical maintenance standards

- (i) Setting of the schedule of periodical maintenance days
- (ii) Establishment of methods of maintenance
 - a) Timing of inspections
 - b) Personnel in charge of inspections
 - c) Spots of which inspections are required
 - d) Measuring devices for inspections and examinations
 - e) Establishment of the limits of use
 - f) Clear indication of countermeasures and methods of repairing

3. Maker's inspection method

We as the maker make the following items of inspections to check whether the Units are normally operated or not.



- (1) Check for deformation, abrasion, stains, and damages of the pads.
- (2) Check for abrasion, clattering, and chipping of the spikes.
- (3) Check for abrasion of the spikes.
- (4) Check for deformation or distortion of the main unit.
- (5) Check for distortion of the shackle.
- (6) Check for defects of bolts, pins, links, and springs.



■ Daily inspection

Daily inspection and maintenance is required for safety and prevention of the degradation of efficiency in operation.

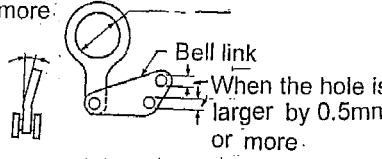
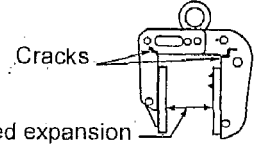
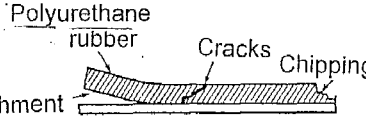
1. Checking for damages such as flaws and cracks on the respective parts of the pads and the shackle.
2. Checking of whether bolts, nuts, pins, etc. are properly installed.
3. Checking of whether each part is properly actuated and lubricated.
4. Checking for deformation, abrasion, and chipping of the pads.
5. Checking for abrasion and chipping of the spikes.
6. Checking for stains on the pads.
7. Refer to the maintenance standards for other details.

■ Maintenance standards

Items	Inspection method	Limit of use	Major causes of defects	Counter-measures										
Shackle	<ul style="list-style-type: none"> ●Check for deformation of the hole. (by measuring device) ●Check for deflection or deformation. (by visual check or measuring device) 	<ul style="list-style-type: none"> ●When the shackle hole is deformed by 1mm or more, or the pin hole is larger by 0.5mm or more: <p style="text-align: center;">When the shackle hole is larger by 1mm or more:</p>  <ul style="list-style-type: none"> ●When the shackle is deflected or deformed by 5 degrees. 	<ul style="list-style-type: none"> ●Overloading ●Sudden impact load ●Unreasonable lifting angle 	Replacement										
Main unit and Arms	<ul style="list-style-type: none"> ●Check for cracks or deformation ●Check for clattering of the caulking pin. (by visual check) 	<ul style="list-style-type: none"> ●When cracks, deformation, etc. are found ●When the clattering of the caulking pin occurs ●When the distance between the most remotely expanded arms is larger than the max. dimension in the capacity indications by the allowable extra distances in the table below at the position of each adjustment plate pin set up (Ref. p.14)  <table border="1" data-bbox="654 1288 1045 1512"> <thead> <tr> <th>Product No.</th> <th>Limit of the allowable expansion of the arms of the unit. (mm)</th> </tr> </thead> <tbody> <tr> <td>PTC100</td> <td>4 or more</td> </tr> <tr> <td>PCT100 PCT150</td> <td>8 or more</td> </tr> <tr> <td>PTC200</td> <td>8 or more</td> </tr> <tr> <td>PTC250</td> <td>8.5 or more</td> </tr> </tbody> </table>	Product No.	Limit of the allowable expansion of the arms of the unit. (mm)	PTC100	4 or more	PCT100 PCT150	8 or more	PTC200	8 or more	PTC250	8.5 or more	<ul style="list-style-type: none"> ●Overloading ●Dropping impact ●Sudden impact load ●Unreasonable lifting angle 	Replacement
Product No.	Limit of the allowable expansion of the arms of the unit. (mm)													
PTC100	4 or more													
PCT100 PCT150	8 or more													
PTC200	8 or more													
PTC250	8.5 or more													
Pads	<ul style="list-style-type: none"> ●Check for cracks on and chipping or detachment of the polyurethane rubber (by visual check) ●Check for deformation of the pads (by visual check or measuring device) 	<ul style="list-style-type: none"> ●When cracks or detachment or chippings are found by visual check:  <ul style="list-style-type: none"> ●When deformation or deflection of 0.5mm or more is found 	<ul style="list-style-type: none"> ●Overloading ●Non-use of pad surfaces, others ●Overloading ●Sudden impact load ●Unreasonable lifting angle 	Replacement										

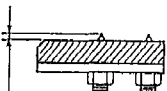
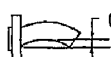
	<ul style="list-style-type: none"> ●Check for abrasion of the polyurethane rubber. (by visual check or measuring device) 	<ul style="list-style-type: none"> ●When the thickness of the pad is reduced to the limit of use as in the table below: <table border="1"> <thead> <tr> <th rowspan="2">Product No.</th> <th colspan="2">Limit of allowable thickness of the pad</th> </tr> <tr> <th>Movable</th> <th>Fixed</th> </tr> </thead> <tbody> <tr> <td>PTC100</td> <td>10mm or less</td> <td>11mm or less</td> </tr> <tr> <td>PSC100 PTC150</td> <td>8mm or less</td> <td>8mm or less</td> </tr> <tr> <td>PTC200</td> <td>8mm or less</td> <td>8mm or less</td> </tr> <tr> <td>PTC250</td> <td>9mm or less</td> <td>9mm or less</td> </tr> </tbody> </table> <p>Polyurethane rubber</p> 	Product No.	Limit of allowable thickness of the pad		Movable	Fixed	PTC100	10mm or less	11mm or less	PSC100 PTC150	8mm or less	8mm or less	PTC200	8mm or less	8mm or less	PTC250	9mm or less	9mm or less	<ul style="list-style-type: none"> ●Natural abrasion ●Others 	
Product No.	Limit of allowable thickness of the pad																				
	Movable	Fixed																			
PTC100	10mm or less	11mm or less																			
PSC100 PTC150	8mm or less	8mm or less																			
PTC200	8mm or less	8mm or less																			
PTC250	9mm or less	9mm or less																			
	<ul style="list-style-type: none"> ●Check for abrasion or chipping of the spikes. (by visual check or measuring device) 	<ul style="list-style-type: none"> ●When the flat surface of the spike point is abraded away to become 0.5mm or more.  <ul style="list-style-type: none"> ●When the spike point is tipped off. 	<ul style="list-style-type: none"> ●Natural abrasion and Others ●Lifting of hard objects such as iron, concrete, stone, etc. 																		
	<ul style="list-style-type: none"> ●Check whether the height of the protrusion of the spike is proper or not. (by visual check or measuring device) 	<ul style="list-style-type: none"> ●When the height of the protrusion of the spike is 1.5mm or less. <p>1.5mm or less</p> 	<ul style="list-style-type: none"> ●Natural abrasion and Others 	Replacement																	
			<ul style="list-style-type: none"> ●Loosened mounting nuts 	Fastening adjustment																	
	<ul style="list-style-type: none"> ●Check for loosened or detached screws for fastening the pads (by visual check) 	<ul style="list-style-type: none"> ●When screws are loosened or clattering. 	<ul style="list-style-type: none"> ●Sudden impact load ●Unreasonable lifting angle 	Fastening adjustment																	
		<ul style="list-style-type: none"> ●When screws (small screws and nuts) are fallen off. 	<ul style="list-style-type: none"> ●Incorrect handling or inspection 	To be fastened with new screws.																	
Adjustment plate pin	<ul style="list-style-type: none"> ●Check for deflection or deformation of the pin. ●Check for cracks or damages. (by visual check or measuring device) 	<ul style="list-style-type: none"> ●When deflection or deformation of 0.5mm or more is found:  <p>0.5mm or more</p> <ul style="list-style-type: none"> ● When cracks, damages, or falling-off of the spring pin are found. 	<ul style="list-style-type: none"> ●Overloading ●Sudden impact load ●Unreasonable lifting angle 	Replacement																	

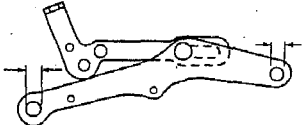
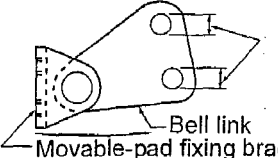
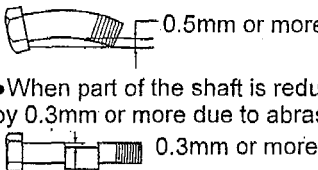
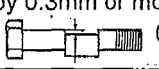
<p>Lock lever link</p>	<ul style="list-style-type: none"> •Check for deformation of the pin holes or link (by visual check or measuring device) •Check for operation of the lock lever.(by visual check) 	<ul style="list-style-type: none"> •When the pin hole is expanded by 0.5mm or more When the hole becomes larger by 0.5mm or more.  <ul style="list-style-type: none"> •When the operation or movement of the lock lever becomes worse due to the deflection or deformation of the link, etc. 	<ul style="list-style-type: none"> •Overloading •Sudden impact load •Unreasonable lifting angle 	<p>Replacement</p>
<p>Cam</p>	<ul style="list-style-type: none"> •Check for deformation of the pin holes. (by visual check or measuring device) •Check for operation of the fixing bracket for the movable pad. (by visual check) 	<ul style="list-style-type: none"> •When the pin hole is expanded by 0.5mm or more When the hole becomes larger by 0.5mm or more.  <ul style="list-style-type: none"> •When the movement of the movable-pad fixing bracket or bell link becomes worse due to the deformation of the bracket or the link. 	<ul style="list-style-type: none"> •Overloading •Sudden impact load •Unreasonable lifting angle •Lack of lubrication and others 	<p>Replacement</p>
<p>Bolts and pins</p>	<ul style="list-style-type: none"> •Check for abrasion or deformation of the shaft. (by visual check or measuring device) •Check for loosened bolts and nuts (by visual check) 	<ul style="list-style-type: none"> •When deflection or deformation of 0.5mm or more is found.  <ul style="list-style-type: none"> •When part of the shaft is reduced by 0.3mm or more due to abrasion.  <ul style="list-style-type: none"> When bolts or nuts are loosened or fallen off. 	<ul style="list-style-type: none"> •Overloading •Sudden impact load •Unreasonable lifting angle •Sudden impact load •Long-time use, others 	<p>Replacement</p>
<p>Spring</p>	<ul style="list-style-type: none"> •Check whether there is proper rebounding, when the shackle is pressed under the locked status. (by visual check) 	<ul style="list-style-type: none"> •When proper rebounding is not confirmed, when the shackle is pressed. •When deformation or breaking of the spring is confirmed by visual check. 	<ul style="list-style-type: none"> •Overloading •Sudden impact load •Fatigue, etc. 	<p>Replacement</p>