



## **ALC Panel Lifting Clamp**

**PAC 260**

## **Molded Board Lifting Clamp**

**PSC 260**

# **Operation Manual**

This operation manual explains the basic operation and handling of the clamps. Please read this manual carefully before use and observe the precautions for safe operation.

***SUPER*TOOL**

## **On the Proper Handling of Lifting Clamps with Super Tool's Mark**

We are thankful to you for your selection and purchase of our Lifting Clamps with Super Tool's mark on them. Our Lifting Clamps with Super Tool's mark on them (hereinafter to be called "Lifting Clamp" or "Clamp") is energy-saving lifting tools designed and developed for transportation of steel materials and other steel products.

### **Proper use of Lifting Clamps demanded**

You are kindly asked to operate the Lifting Clamps after careful reading and understanding of this instruction manual for the purpose of enhancing safety and efficiency at work.

### **Prime efficiency and economy**

The sophisticated functions, reasonableness and wide applications of the finely and carefully designed Lifting Clamps ensure prime efficiency and economy.

### **Special care of safety**

We have executed tensile tests with loads three times (or twice) the rated capacity according to the testing standards set forth by the National Institute of Industrial Safety of Ministry of Labor and attached inspection numbers to individual products, thus directing special attention to the aspect of safety.

### **Cautions for safety operation**

Please do not fail to carefully read this instruction manual before use of the Lifting Clamps.

Mistaken use of the Lifting Clamps (hereinafter to be called "Clamps") may cause troubles such as the dropping of load.

Never fail to carefully read this manual for proper operation before use.

Education of "crane safety regulations," "operation manual for lifting clamps," "in-house operation standards," etc. should be given before actual operation not only to business owners who have purchased the Clamps but also to their operators to ensure that actual operators have acquired enough knowledge of clamps, safety information, and cautions.

As according to the "Lifting clamp safety council," we have divided cautions in general into "Dangers" and "Cautions," which are used in this instruction manual.

<b>◇DANGER:</b> Indicates mistaken handling may cause a potentially hazardous situation which, if not avoided, could result in death or serious injury.
---

<b>△CAUTION:</b> Indicates mistaken handling may cause a potentially hazardous situation which, if not avoided, could result in medium damage or slight injury, or could result in property damage.
---

Even though only mentioned in the Cautions, those incidents may lead to a serious disaster. So, do not fail to pay attention both to dangers and cautions which are of great importance in operating the Clamps properly.

### Meanings of Signs



The signs of ◇ and △ indicate that attention is to be given to the marks indicative of dangers and cautions respectively. The signs figuratively show the contents of danger or caution. (The left-side sign indicates a caution to the pinching.)

The sign indicates prohibited actions.





The sign of ○ indicates that an action is enforced or instructed to be executed. Inside the sign or beside it is shown a concrete instruction is described.

\* After reading of this manual, please keep it at a convenient place to which any user can gain easy access for reference.



### 1. About handling in general

<b>Dangers</b>	
<ul style="list-style-type: none"> <li>● Any person who is not well-informed about instruction manual, tags, and signs of cautions is not eligible for use of the Lifting Clamps.</li> <li>● Any person who is not legally qualified is never to operate a crane and a lifting clamp. (Clauses 221 and 222, Crane Safety Regulations)</li> <li>● While lifting or turning the work, do not enter the area where the lifted work threatens to drop off or fall over. (Clauses 28 and 29, Crane Safety Regulations)</li> <li>● Do not use this lifting clamp for other purposes than lifting work.</li> </ul>	
<ul style="list-style-type: none"> <li>● Never fail to execute a before-use and periodical inspection. (Clauses 217 and 220, Crane Safety Regulations)</li> </ul>	





### 2. About checking before operation

<b>Dangers</b>	
<ul style="list-style-type: none"> <li>● Do not use a clamp other than applicable to the operation method.</li> <li>● Do not use an abnormal clamp with deformation, cracks, operational trouble, abrasion, etc.</li> <li>● If the load is under the following conditions, do not use the clamp. (fragile material, high-hardness material, low-hardness or extremely low-hardness material, and members with the gripping part of no direction tapered down to the edge and of more than 8 degrees in temperature of itself)</li> </ul>	
<ul style="list-style-type: none"> <li>● Please check on the clamp main unit the type, basically applicable load, opening diameter, and indication of periodical inspections executed.</li> <li>● The load shall be within the allowable range of the basically applicable load of the clamp.</li> <li>● The thickness of the load shall be within the allowable clamping range.</li> </ul>	
<b>Cautions</b>	
<ul style="list-style-type: none"> <li>● Do not use the clamp for the work under the following conditions. (The load is more than 150 degrees, is less than minus 20 degrees in temperature, and acidic or alkaline chemicals.)</li> </ul>	
<ul style="list-style-type: none"> <li>● The sling to be used for the clamp shall be an appropriate one for the lifting operation.</li> </ul>	

### 3. About the method of use and lifting operation



<b>◇Dangers</b>	
<ul style="list-style-type: none"> <li>●Do not use the Clamp, lifting at one point. (excluding special products or custom ordered products)</li> <li>●Do not use the Clamp in the following way of lifting: (overlapped works, padded work, engrafted lifting, concurrent lifting, and side gripping)</li> <li>●Do not use the Clamp for pulling out from among steel sheet pilings and not lift pulled-out steel sheets vertically.</li> <li>●Do not use the Clamp when strong wind threatens to cause any danger.</li> <li>●Do not use the Clamp for a hydraulic excavator.</li> </ul>	
<ul style="list-style-type: none"> <li>●Install two or more Clamps in a balanced way to keep the work's balance.</li> <li>●The lifting angle of the Clamp and the dividing angle should be kept within the allowable angles according to types.</li> <li>●The work is to be inserted to the innermost end of the Clamp opening.</li> <li>●When you use the Clamp with a locking system, never fail to use the Clamp with the locking system on.</li> </ul>	
<b>△Cautions</b>	
<ul style="list-style-type: none"> <li>●If oil, paint, scales, rust, etc. are on the gripping pad, do not use the Clamp.</li> <li>●Do not drop to the ground or drag along the ground the Clamp.</li> </ul>	

### 4. About the operation of a crane

<b>◇Dangers</b>	
<ul style="list-style-type: none"> <li>●Never lift the work weighing more than the basic working load.</li> <li>●Do not operate the crane in such a way as to give an impacting load to the work or the Clamp.</li> <li>●Do not allow a person to stand on the load. Never use the Clamp for the purpose of carrying him.</li> <li>●Do not lift the earth itself.</li> <li>●In the course of lifting the work, do not release the lock of the Clamp.</li> <li>●Do not let the Clamp removed from the work collide with the work or an adjacent member.</li> </ul>	
<ul style="list-style-type: none"> <li>●When you wind up the wire by the crane and notice the load at the lifting ring, stop the operation temporarily for safety checking (depth of the work into the Clamp opening; status of locking).</li> <li>●Stop the operation of the crane just before the work reaches the ground, check the following items of things: (Slant and falling over of the work; security at the landing site and its surrounding)</li> </ul>	
<b>△Cautions</b>	
<ul style="list-style-type: none"> <li>●Do not operate the crane in such a way as to drag the work along the ground.</li> <li>●Do not step away from the crane (winder, etc.) operating position while keeping the work being lifted with the Clamp.</li> </ul>	
<ul style="list-style-type: none"> <li>●Hoisting and lowering by the crane should be operated slowly and carefully.</li> </ul>	

### 5. About maintenance, storage and remodeling

<b>◇Dangers</b>	
<ul style="list-style-type: none"> <li>●Never execute any remodeling of the Clamp and its accessories.</li> <li>●Do not apply welding work or heating to the Clamp and its accessories.</li> <li>●Do not use any other parts than our company's brand-name parts.</li> <li>●Store at a different place Clamps requiring repairing not to be used mistakenly.</li> <li>●A person with specialized knowledge specified by the business owner is to</li> </ul>	

<p>conduct maintenance and repairing work.</p> <ul style="list-style-type: none"><li>●When you detect abnormality with the Clamp, do not use it and immediately repair or dispose of it.</li><li>●Remove, if any, paint or mud sticking to the moving parts of the Clamp, cams, and pads.</li></ul>	
<p><b>△Cautions</b></p>	
<ul style="list-style-type: none"><li>●Conduct maintenance and repairing without any loads.</li><li>●Conduct maintenance and repairing after posting a sign indicating that you're working on the maintenance work.</li><li>●Never fail to lubricate oil on the rotating part of the Clamp (around the pin), guide groove, sliding parts, etc.</li><li>●Store Clamps inside a room.</li></ul>	

# Panel Lifting Clamp for Housing

## PAC 260/PSC 260

### ■ Uses

Optimal for lifting and moving of and construction work for panels for housing.

Description	Item No.	Uses
ALC panel Lifting Clamp	PAC260	This unit is optimal for lifting and moving of and construction work for panels for Autoclaved Lightweight aerated Concrete (ALC).
Molded board Lifting Clamp	PSC260	This unit is optimal for lifting and moving of and construction work for panels for molded cement board.

### ■ Features

1. The units are compact and light, and so are easy to use.
2. In proportion to lifting load, tightening strength will increase, clamping the work securely.
3. The clamping range is wide and adjustable with an adjustment plate pin.
4. Because of the spikes attached on the movable pads (panel-clamped part), no slipping between the panel and the clamp will occur ensuring safety execution.
5. Polyurethane rubber is used for the fixed pad, so the front side of the panel is not susceptible to scratches.
6. Working efficiency can be enhanced as the tightening lock can be unlocked by remote control.
7. Clamps are hard to be caught at scaffoldings with a catch-prevention cover, and it is especially safe to hang the panel.
8. With a safety hook bolt, the clamp main body can be mounted with a sling belt for double safety.

### ■ Specifications

Description/ Item No.	Capacity	Clamping Range (Pin adjustment type)	Product Weight
ALC panel Lifting Clamp PAC260	260kg	Level. 1: 90-105mm Level. 2: 115-130mm Level. 3: 140-155mm	6.9kg
Molded board Lifting Clamp PSC260	260kg	Level. 1: 50-65mm Level. 2: 70-85mm	6.9kg

# General dimensional drawing

## ●PAC260

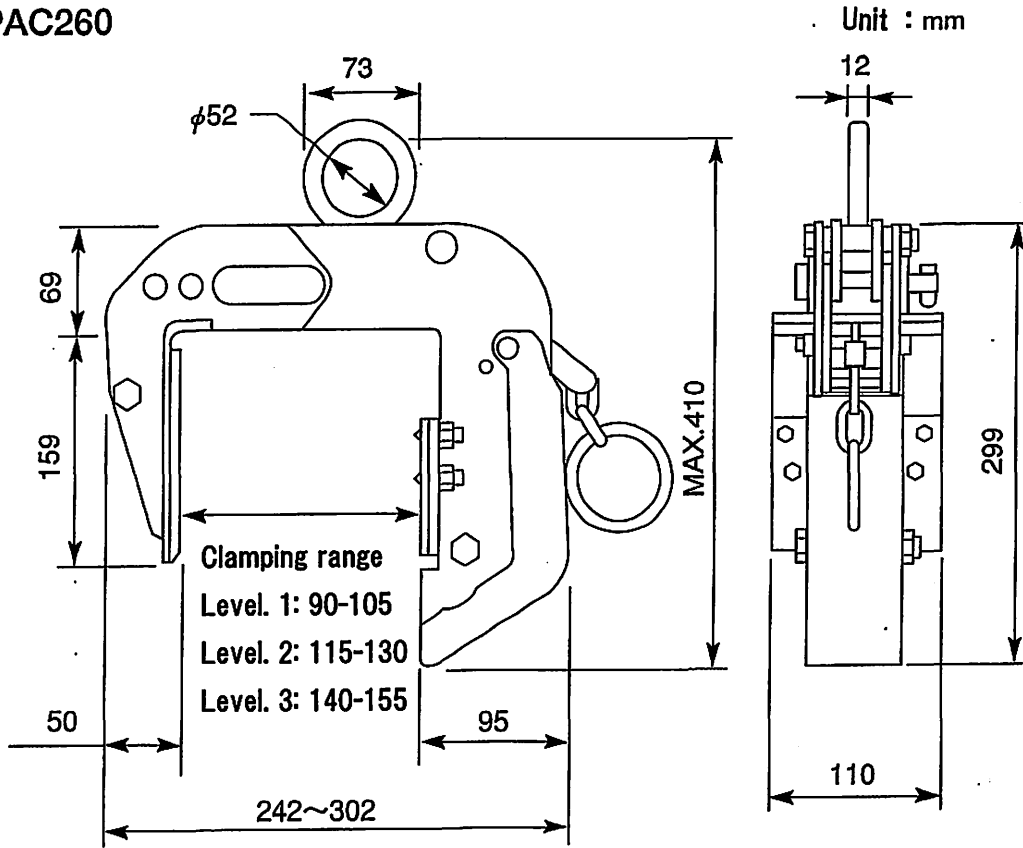

## ●PSC260

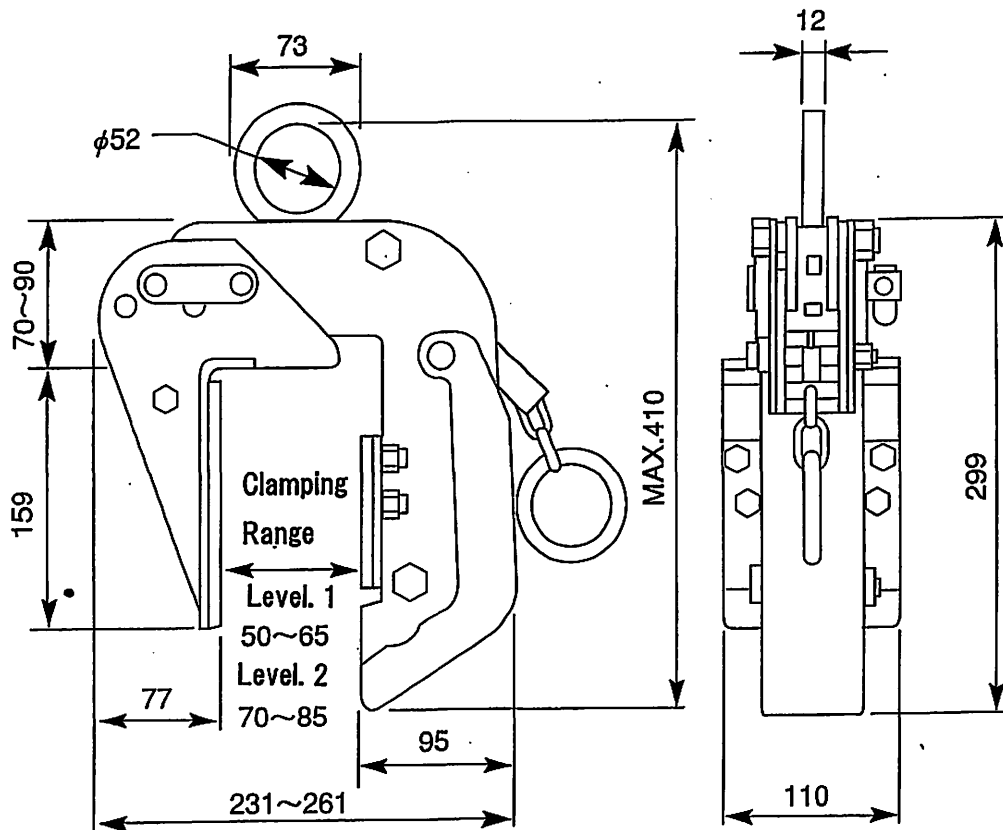

# PAC260 Parts Name

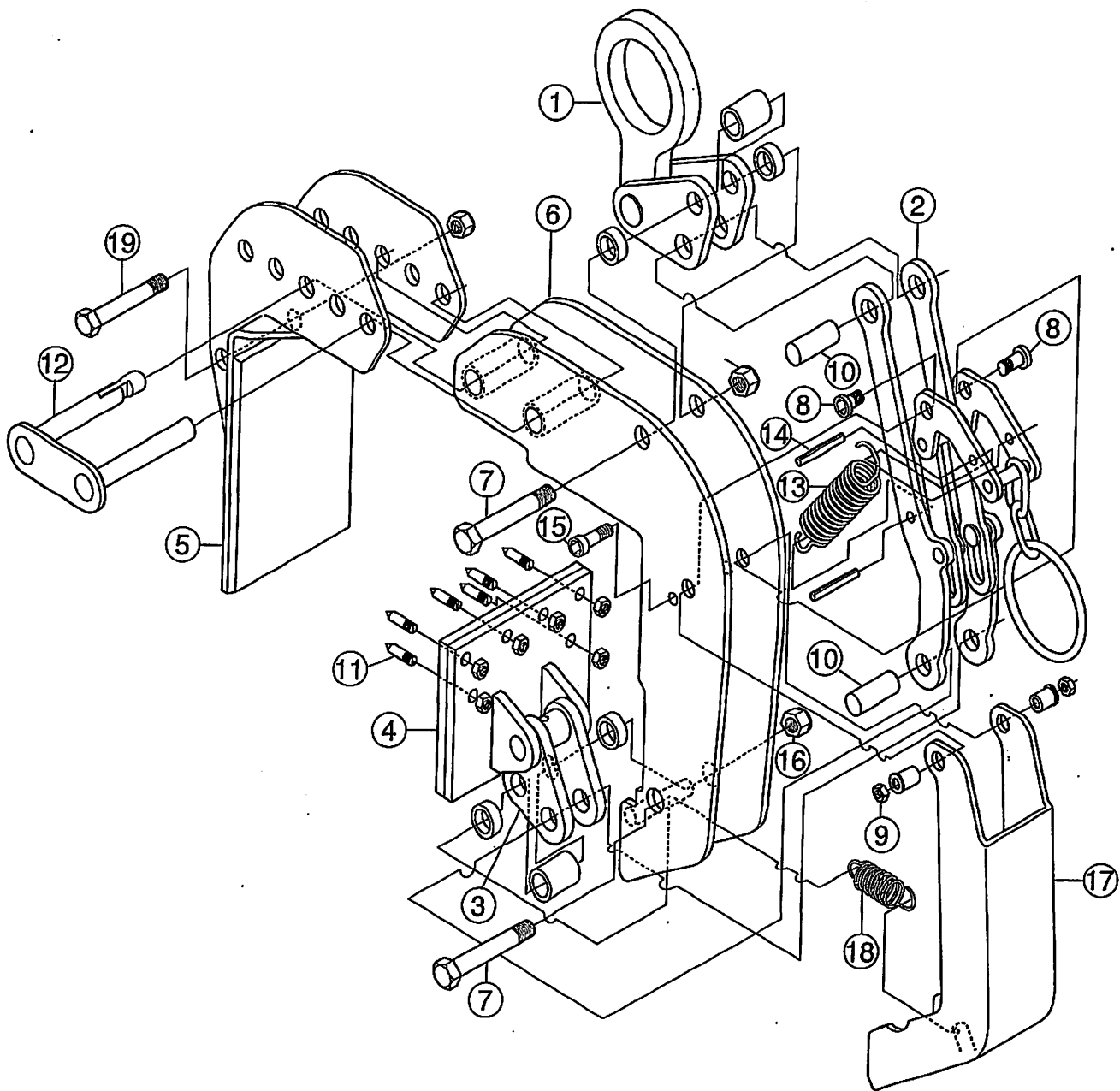

Parts No.	Parts Name	Item No.	Set Number
<b>SHACKLE</b>			
1	Shackle	PAH	1
7	Bolt with short and long collars	PACH	1
16	U-shaped nut	PACN	1
<b>LOCK LEVER LINK</b>			
2	Lock Lever Link	PAF	1
8	Hex. hole head disc bolt with collar washer	PACF	2
9	U-shaped nut	PACD	2
10	Pin	PACP	1
13	Spring for lock	PACS	1
14	Spring Pin	PACA	1
15	Hex. hole head bolt	PACB	2
<b>MOVABLE PAD</b>			
3	Cam link with pin collar	PAE	2
7	Bolt with short and long collars	PACT	1
16	U-shaped nut	PACN	1
10	Pin	PACP	1
4	Movable pad	PACE	1
11	Spike	PACG	6

Parts No.	Parts Name	Item No.	Set Number
<b>FIXED PAD FOR PAC260</b>			
5	Fixed Pad	PAR	1
19	Safety hook bolt/nut	PACR	1
12	Adjustment plate pin	PACV	1
<b>COVER</b>			
17	Cover	PAJ	1
18	Spring for cover	PACJ	1
<b>ROPE(common)</b>		PACU260	1

\*No.6 is a main body, which is not for sale.



# PSC260 Parts Name

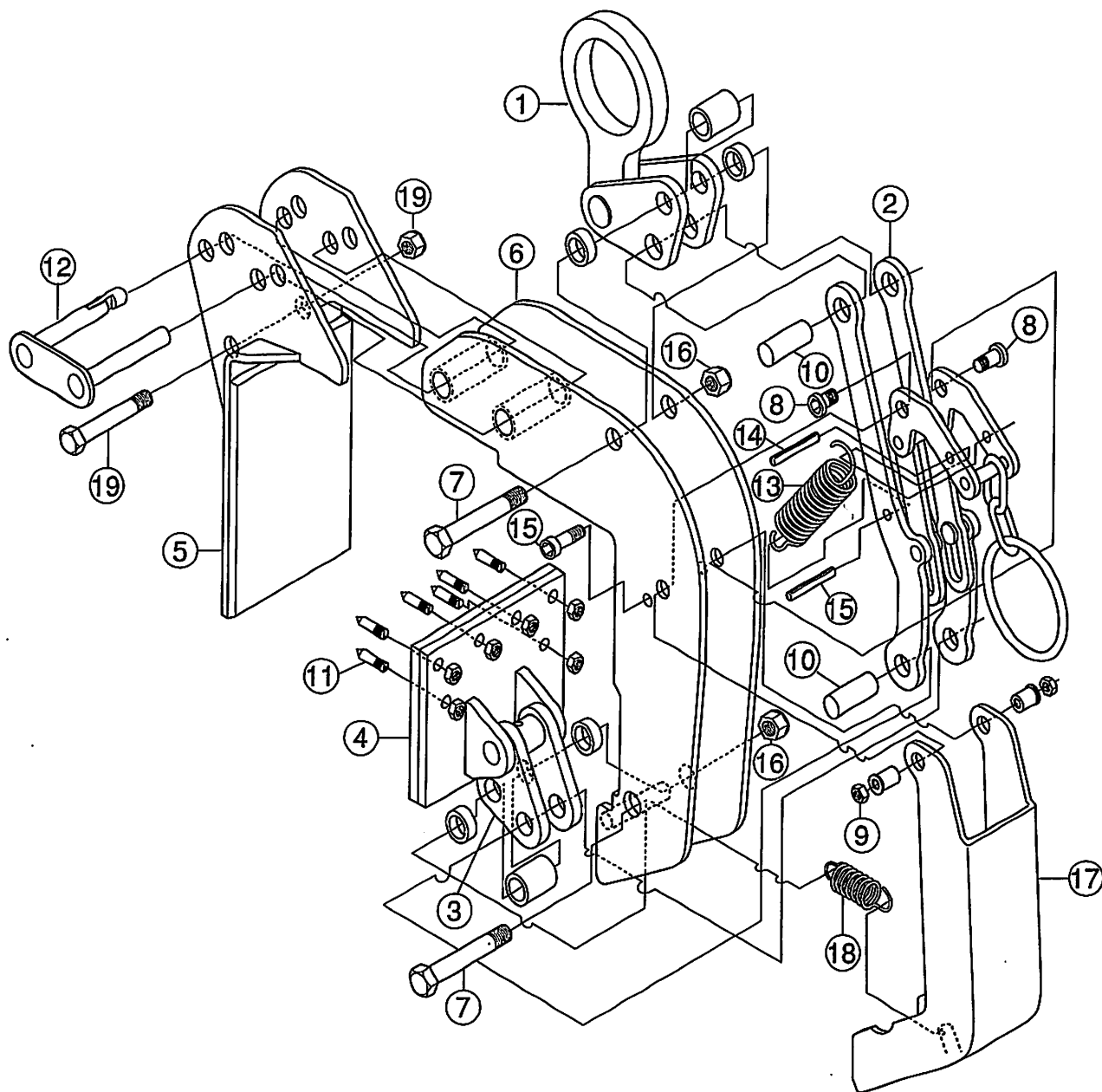

Parts No.	Parts Name	Item No.	Set Number
<b>SHACKLE</b>		<b>PAH</b>	
1	Shackle	PACH	1
7	Bolt with short and long collars	PACN	1
16	U-shaped nut		1
<b>LOCK LEVER LINK</b>		<b>PAF</b>	
2	Lock Lever Link	PACF	1
8	Hex. hole head disc bolt with collar washer	PACD	2
9	U-shaped nut		2
10	Pin	PACP	1
13	Spring for lock	PACS	1
14	Spring Pin	PACA	1
15	Hex. hole head bolt	PACB	2
<b>MOVABLE PAD</b>		<b>PAE</b>	
3	Cam link with pin collar	PACT	2
7	Bolt with short and long collars	PACN	1
16	U-shaped nut		1
10	Pin	PACP	1
4	Movable pad	PACE	1
11	Spike	PACG	6

Parts No.	Parts Name	Item No.	Set Number
<b>FIXED PAD FOR PSC260</b>		<b>PSR</b>	
5	Fixed Pad	PSCR	1
19	Safety hook bolt/nut	PSCV	1
12	Adjustment plate pin	PACK	1
<b>COVER</b>		<b>PAJ</b>	
17	Cover	PACJ	1
18	Spring for cover	PACL	1
<b>ROPE(common)</b>		<b>PACU260</b>	<b>1</b>

\*No.6 is a main body, which is not for sale.

## How to Use

1. Refer to the right figure how to attach the remote control rope.
2. Adjust the clamping range according to the thickness of the panel by replacing the plate pin. When replacing the adjustment pin, insert the pin sufficiently into the main body and exit the pin until the toggle head is bent.

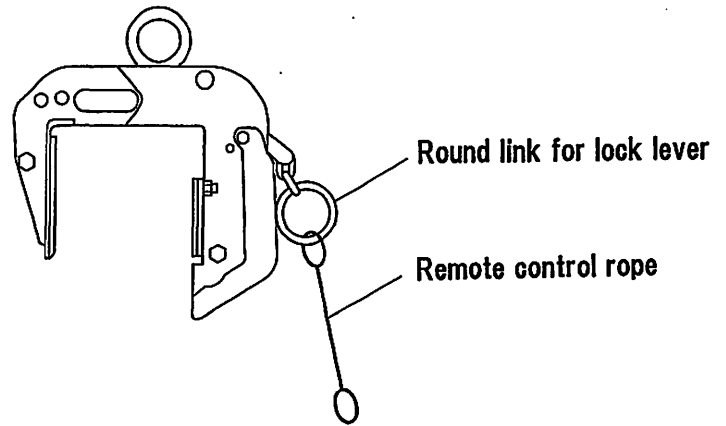

### ●PAC260

Adjustment plate pin

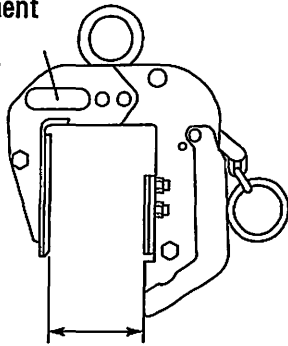

Clamping range (1) 90~105mm

Adjustment plate pin

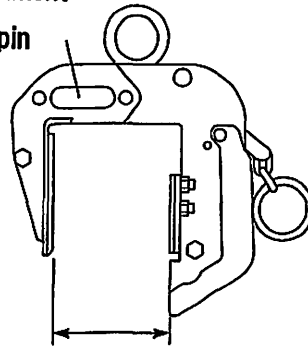

Clamping range (2) 115~130mm

Adjustment plate pin

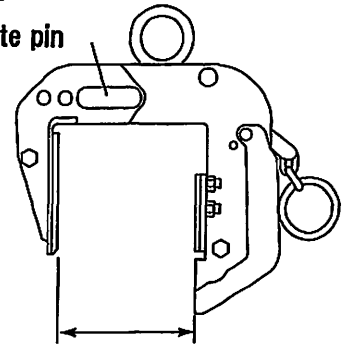

Clamping range (3) 140~155mm

### ●PSC260

Adjustment plate pin

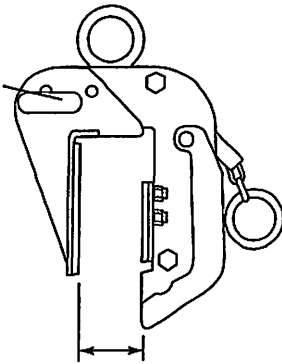

Clamping range (1) 50~65mm

Adjustment plate pin

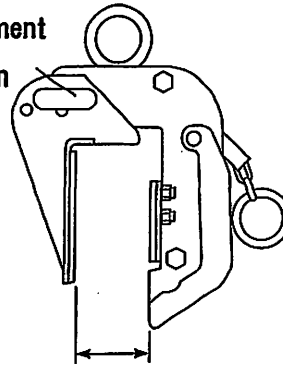

Clamping range (2) 70~85mm

3. Lower the lock lever and confirm that the arms are opened.

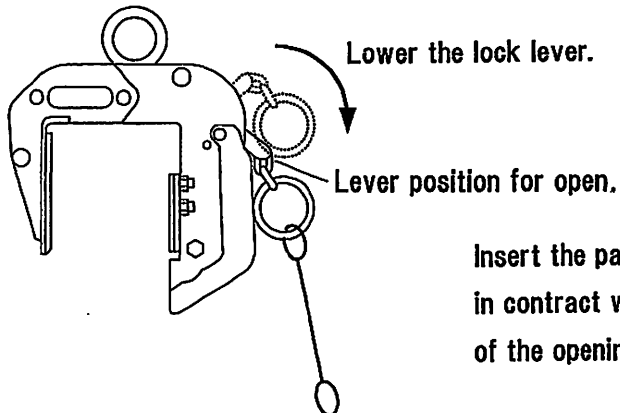

4. Insert the panel into the opening of the lifting clamp while it is open until the upper surface of the panel comes in contact with the opening, and raise the lock lever to lock the panel. Then lifting is ready.

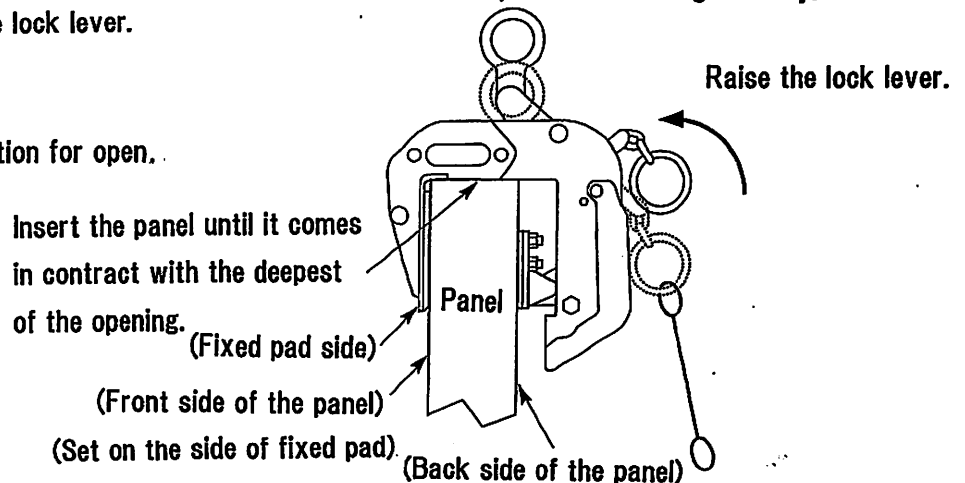

- After confirmation that the lock lever is locked, lift the crane and transport the panel to the specified location.  
Use a balance (PSB) for lifting with two-point lifting.

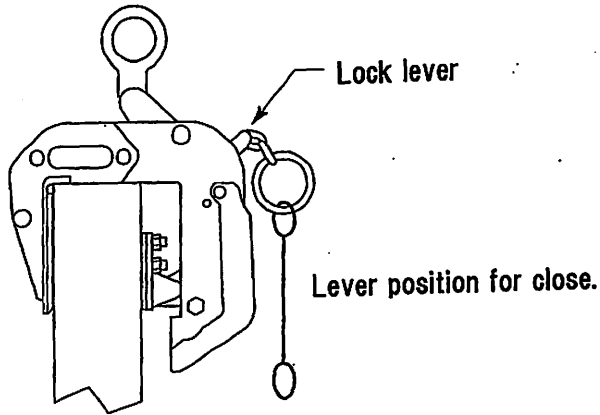

- The clamp main body has a hook for mounting the sling belt for double safety. Use it for safer operation. This is a subsidiary hook part for safety. Do not use it by itself.  
(Sling belts should be prepared by the customer.)

Example of balance use

- Holding longer side

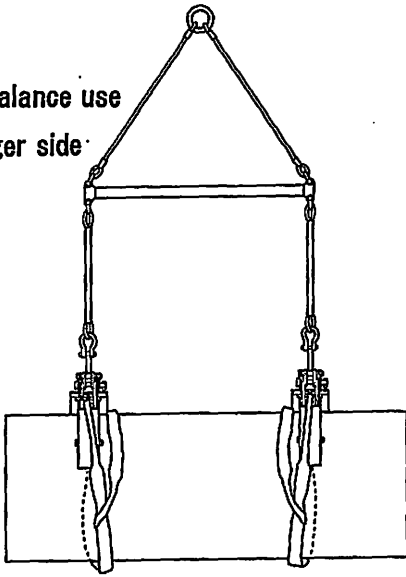

Example of use when a balance is not used.  
Mount the sling belt on the safety hook bolt of the clamp main body for double safety.

- Holding longer side

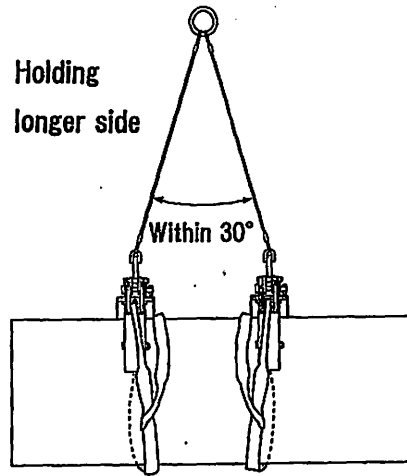

- Holding shorter side

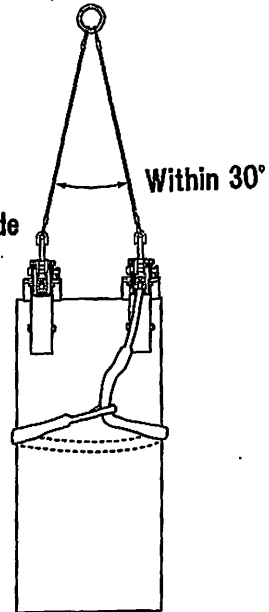

- After transporting the panel to the specified position, lower the crane and confirm that the panel is completely onto the ground.
- Lower the crane to loosen the wire rope sufficiently. Then, pull down the lock lever to release the lock. (The lock cannot be released when the crane is not lowered completely.) Mount the panel temporarily, loosen the wire rope, and open the clamp.

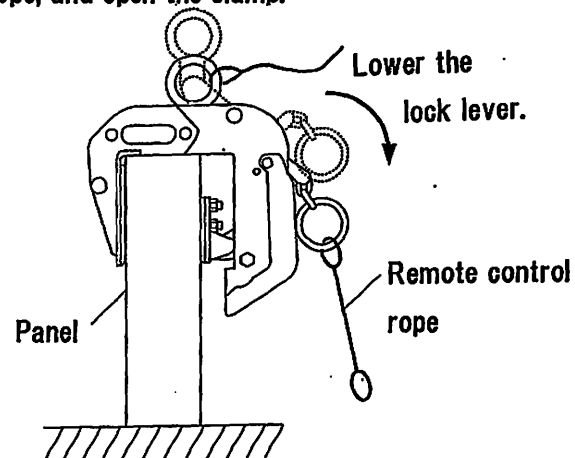

- Check the clamping range before proceeding to the next operation. Repeat from the procedure No. 3.

## Warning

1. Do not enter within the dangerous range during lifting to avoid falling accidents.
2. Do not lift a panel with a thickness outside the clamping range.
3. Check the weight of the panel. Do not lift the load over the capacity of the lifting clamp.
4. Be sure to lift the center and center of gravity of the load when setting the lifting clamp. Be sure to lift two points and use a balance (PSB610) as much as possible.

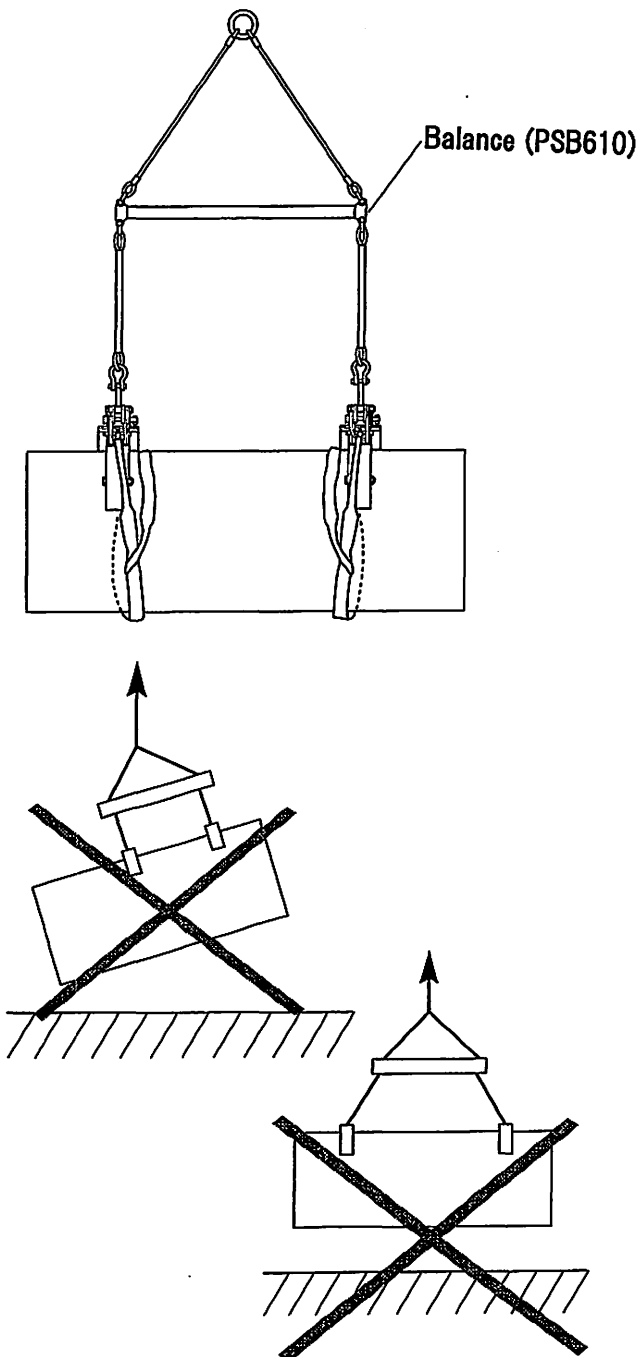

5. Do not lift more than two plates simultaneously. Falling accidents of the panel may occur. Be sure to lift only one sheet.

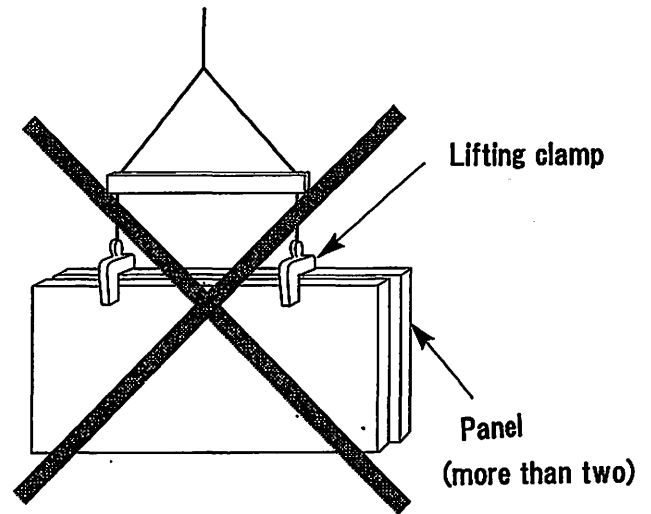

6. Do not lift the panel with side gripping. Tightening force of the clamp may become less and result in danger.

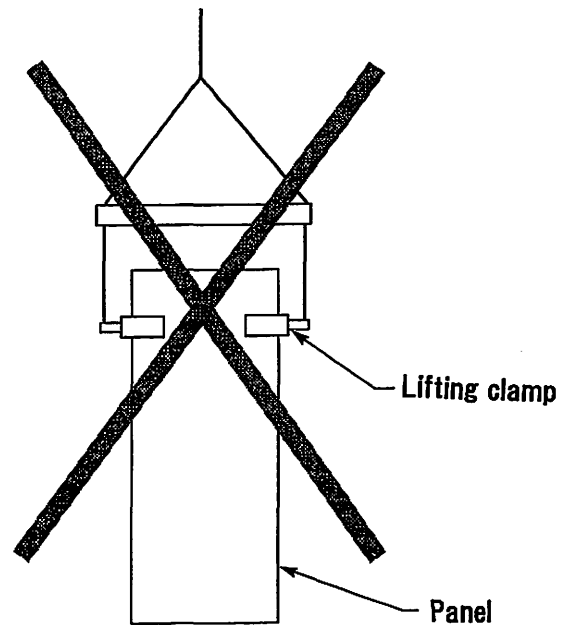

7. Do not hit lifting clamp or lifting load to other objects during lifting.  
(Be careful especially during hanging.)  
Impact or loose rope may cause falling accidents.

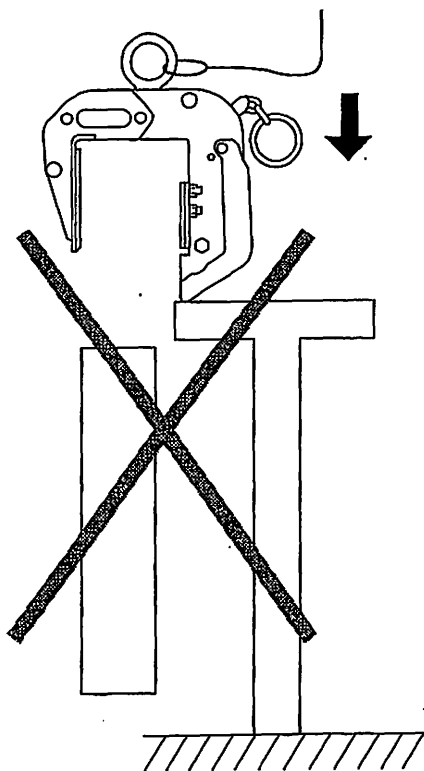
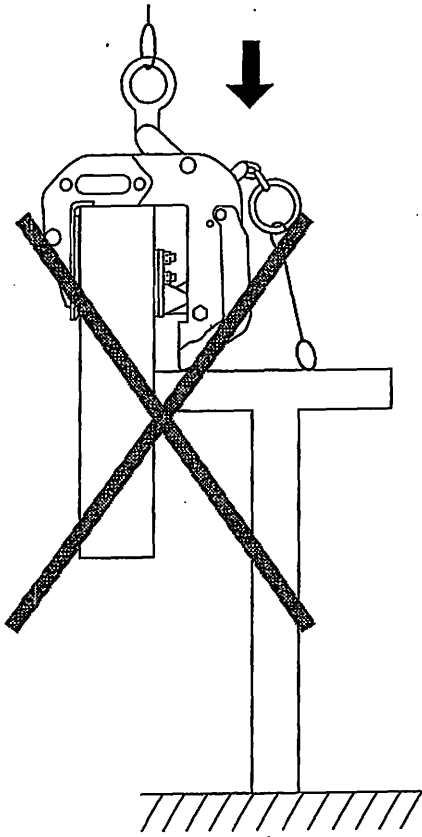

8. Be careful not to catch the remote control ropes on obstacles such as scaffoldings during lifting and hanging. (The lock lever will be opened and the clamp may come off, leading to falling accidents.)

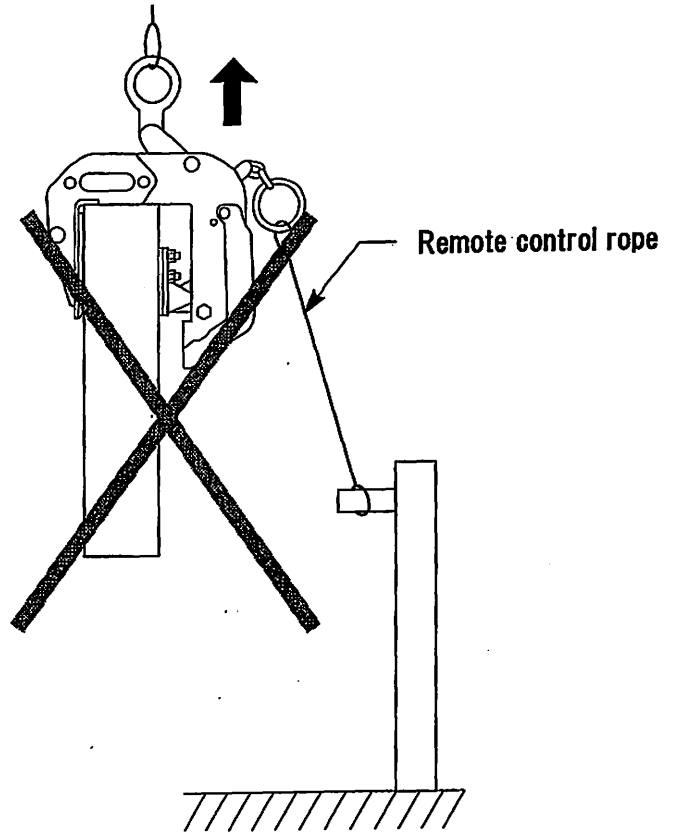

9. Do not use the pad or panel (load) with water, ice, snow, oil, sand, mud, etc.

10. Keep the protrusion of the spikes on the movable pad side between 1.5 and 2 mm.

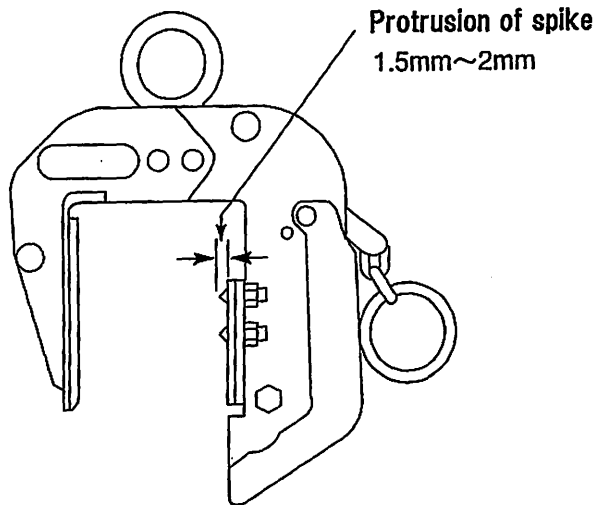

11. Do not alter the product by welding or cutting by gas.

12. When locking the lock lever, be careful not to pinch your hands or fingers between the lock lever and the main body.

13. Mount the clamp so that the lock lever side is upward when pulling the clamp.

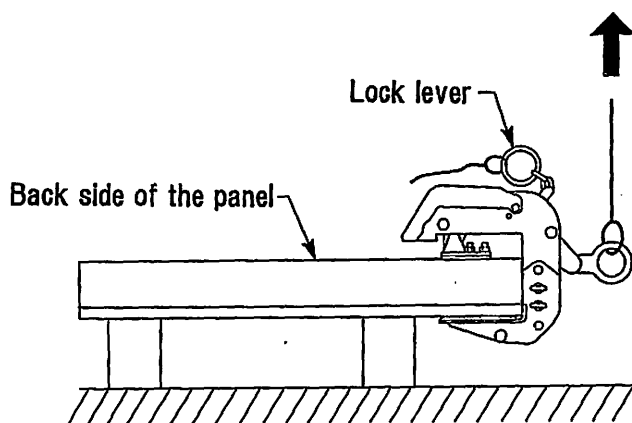

14. When lifting the molded plate in the upright direction, make sure that the frame column is on the surface of the clamp pad. Clamping the part where there's no frame column may cause damage or falling of the panel.

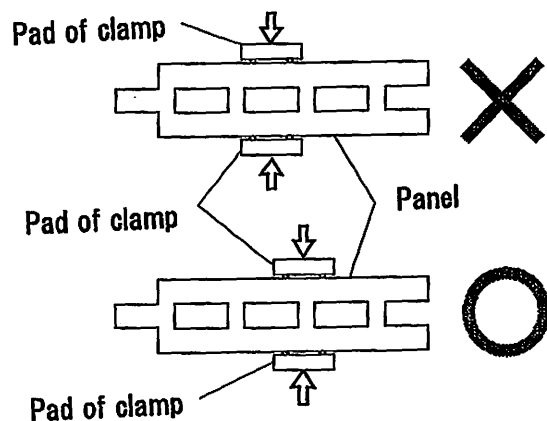
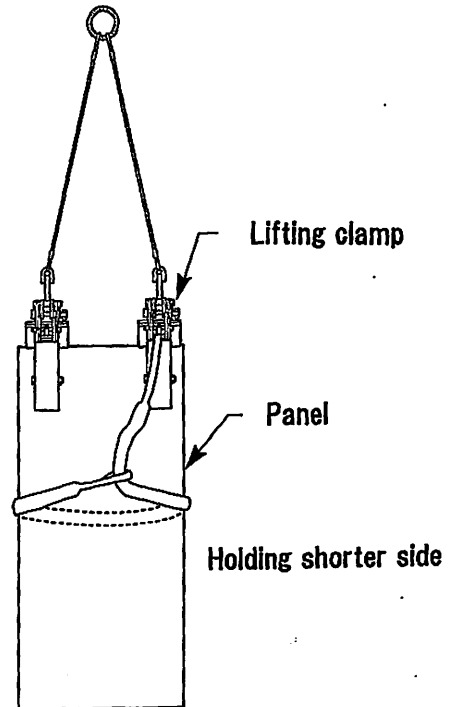

15. When lifting a single-sided tiled panel, set the non-spiked fixed pad side on the tile surface (panel surface) and clamp it. Do not clamp the panel on which spikes do not enter both sides such as metals and tiles. Falling accidents may occur.

16. Perform daily inspections on each part for the normal operation of each parts.

# Maintenance and Inspection of Lifting Clamp

## 1. How to maintain lifting clamp

Daily maintenance is important for efficient and safe operation even under the severe use condition. For such purposes, please comply with the followings.

- (1) Make the use conditions explicit and control.
- (2) Keep clamps in-house and do not leave them outside.
- (3) Inspect the followings to maintain in a good condition.
  - (a) Operating condition.
  - (b) Wear of pad or spike.
  - (c) Deformation or distortion of main body.
- (4) If a hazardous lifting clamp is found during use or inspection, clearly indicate the parts to be repaired and distinguish it from conforming products and immediately repair it.
- (5) Lubricate operation parts such as bolt and pin once a week. (Be careful not to lubricate surface of polyurethane rubber pad. Falling accidents of load may occur.)

## 2. Periodic Inspection

Perform periodic inspection in accordance with the periodic inspection and maintenance standards. Functions and life of clamps may differ in a great degree as they are used in varieties of fields under different conditions of use. Therefore, preparation and practice of effective handling/inspection standards manual by users themselves are recommended. We ask you to establish complete maintenance and control for the assurance of safety in reference to the inspection standards of "Super" clamp. If abnormalities are found, clearly identify the parts to be repaired, and to keep the adequate condition of the clamp. For your preparation of the standards, pay special attention to the followings.

- (1) Operation and maintenance standards
  - (A) Preparation of standards for use (Load shape, operating methods).
  - (B) Thorough understanding and compliance of cautions on handling.
  - (C) Maintain rules of inspection and check at site.
- (2) Standards on periodic inspection
  - (A) Establishing dates of periodic inspection.
  - (B) Establishing inspection and maintenance methods.
    - (a) Inspecting period.
    - (b) Person in charge for the inspection.
    - (c) Inspection site.
    - (d) Tools for inspection and check.
    - (e) Establishment of permissible limit of use.
    - (f) Designation of maintenance and repair methods.

### **3. How to inspect**

**We check condition of followings.**

- (1) Operating condition.**
- (2) Wear of pad.**
- (3) Wear of spike.**
- (4) Deformation or distortion of main body.**
- (5) Distortion of shackle.**
- (6) Condition of bolt, pin, link, spring, etc.**
- (7) Other categories of inspection on the inspection standards.**

#### **■Daily inspection**

**Conduct daily inspection and maintenance to prevent the loss of safety and efficiency.**

- 1. No scratches or cracks in the main body, pad, or shackle.**
- 2. Set condition of bolts, nuts, and pins, etc.**
- 3. The operation and lubrication condition of each part.**
- 4. Wear or chipping of pad.**
- 5. Wear or chipping of spike.**
- 6. Refer to the inspection standards.**

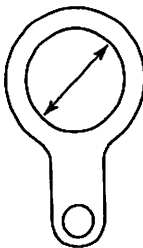
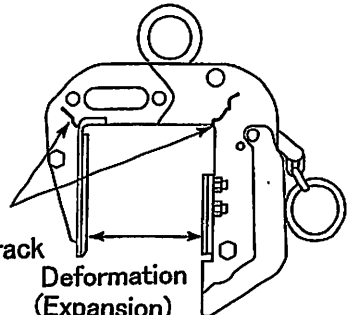
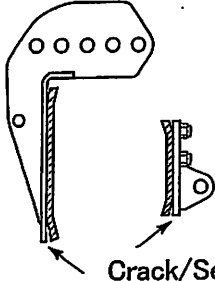
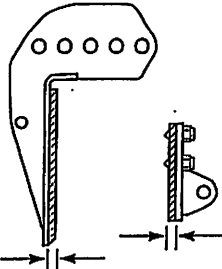
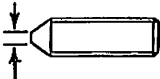
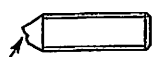

## ■ INSPECTION STANDARDS

Category	Inspecting Method	Limit of use	Main failure cause	Counter-measures
Shackle	<ul style="list-style-type: none"> <li>● Measure shackle hole diameter.</li> </ul>	<ul style="list-style-type: none"> <li>● When the hole diameter exceeds 1 mm due to deformation.</li> </ul> 	<ul style="list-style-type: none"> <li>● Overload.</li> </ul>	Replace
Main body	<ul style="list-style-type: none"> <li>● Visually check wear or deformation.</li> </ul>	<ul style="list-style-type: none"> <li>● When a crack or deformation is found visually.</li> </ul>  <p>Crack Deformation (Expansion)</p>	<ul style="list-style-type: none"> <li>● Overload.</li> <li>● Impact by falling, etc.</li> </ul>	Dispose
Pad	<ul style="list-style-type: none"> <li>● Visually check crack or abrasion of polyurethane rubber.</li> </ul>	<ul style="list-style-type: none"> <li>● When a crack or abrasion is found visually.</li> </ul>  <p>Crack/Separation</p>	<ul style="list-style-type: none"> <li>● Overload.</li> <li>● Use except the plane surface of pad.</li> </ul>	Replace
	<ul style="list-style-type: none"> <li>● Measure wore thickness of polyurethane rubber pad.</li> </ul>	<ul style="list-style-type: none"> <li>● Wear of polyurethane rubber.</li> </ul>  <p>When the tickness is less than 4mm.</p>	<ul style="list-style-type: none"> <li>● Natural wear.</li> </ul>	
	<ul style="list-style-type: none"> <li>● Check wear or chip of spike.</li> </ul>	<ul style="list-style-type: none"> <li>● When the plane surface of top is worn.</li> </ul>  <p>PAC: more than 1.4mm. PSC: more than 0.5mm.</p> <ul style="list-style-type: none"> <li>● When the thread is chipped.</li> </ul> 	<ul style="list-style-type: none"> <li>● Natural wear or others.</li> </ul>	

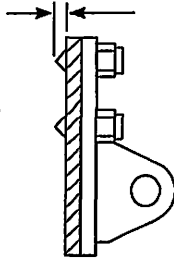
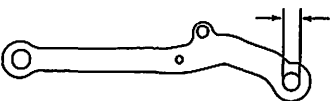
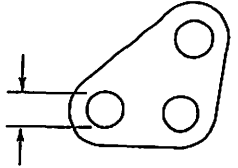
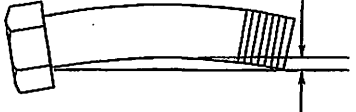
Category	Inspecting Method	Limit of use	Main failure cause	Counter-measures	
Pad	<ul style="list-style-type: none"> <li>● Check protrusion of spike.</li> </ul>	<ul style="list-style-type: none"> <li>● When the protrusion of spike is less than 1.5mm.</li> </ul> <p>The protrusion of spike is less than 1.5mm.</p> 	<ul style="list-style-type: none"> <li>● Natural wear or others.</li> </ul>	Replace	
Lock lever link part	Lock lever link	<ul style="list-style-type: none"> <li>● Measure pin hole diameter or deformation of link.</li> </ul>	<ul style="list-style-type: none"> <li>● When the pin hole is stretched or bent more than 0.5mm.</li> </ul>  <ul style="list-style-type: none"> <li>● When abnormal noise or catching occur.</li> </ul>	<ul style="list-style-type: none"> <li>● Overload.</li> <li>● Impossible clamping angle.</li> <li>● Sudden shock load.</li> <li>● Overload.</li> <li>● Shortage of lubrication.</li> </ul>	Replace
	Upper and lower sides bell link	<ul style="list-style-type: none"> <li>● Measure diformation of pin hole.</li> </ul>	<ul style="list-style-type: none"> <li>● When pin hole is streched more than 0.5mm.</li> <li>● When abnormal noise or catching occur.</li> </ul> 	<ul style="list-style-type: none"> <li>● Overload.</li> <li>● Natural wear.</li> </ul>	Replace
Bolt or pin	<ul style="list-style-type: none"> <li>● Measure wear or deformation of flame part.</li> </ul>	<ul style="list-style-type: none"> <li>● When the wear or disformation exceeds 0.5mm.</li> </ul>  <p>0.5mm or more</p>	<ul style="list-style-type: none"> <li>● Overload.</li> <li>● Sudden shock load.</li> <li>● Natural wear.</li> </ul>	Replace	
Spring	<ul style="list-style-type: none"> <li>● Check if there is an appropriate repulsive force when locking and pushing the shackle.</li> <li>● Check if the spring does not fall off or there is no disengagement.</li> </ul>	<ul style="list-style-type: none"> <li>● When the spring does not react when the shackle is pushed down.</li> <li>● When the bend of the spring can be confirmed visually.</li> <li>● When the hook of the spring is removed from the mounting pin.</li> </ul>	<ul style="list-style-type: none"> <li>● Fatigue, others.</li> <li>● Sudden shock load.</li> <li>● Fatigue, others.</li> </ul>	Replace	
Cover	<ul style="list-style-type: none"> <li>● Check deformation, etc.</li> </ul>	<ul style="list-style-type: none"> <li>● When the cover does not move smoothly due to deformation, etc.</li> </ul>	<ul style="list-style-type: none"> <li>● Poor handling due to impact, etc.</li> </ul>	Replace	