



Balance with hook for fork lift

FLH1

FLH2

Operation Manual

This operation manual explain the basic usage and handling of clamps. Please do not fail to carefully read this instruction manual before use and never fail to follow each attention of usage for the proper handling of clamps.

SUPER TOOL CO., LTD.

Balance with hook for fork lift

FLH1 FLH2

FEATURES

1. Attaching of the balance will change a fork lift to a mobile crane.
2. Only tighten the securing bolts to fix the balance.
3. The latch is attached to the swivel hook for omnidirectional-operation and is vibration-proof.

SPECIFICATIONS

Item No.	Rated capacity (ton)	Applicable fork (mm)		Net weight (Kg)
		Width	Thickness	
FLH1	1	70~120	15~40	12
FLH2	2	120~150	38~65	24

MAJOR DIMENSIONS AND PARTS NAMES

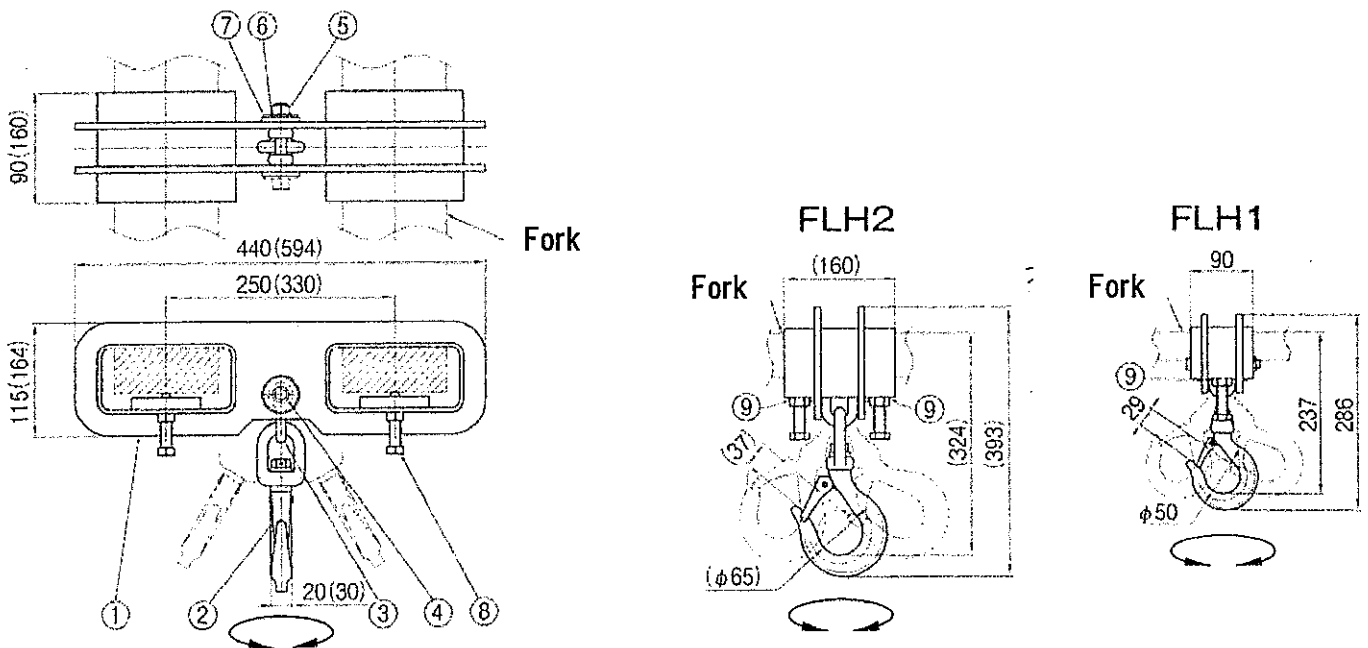

No.	Parts Name	Q'ty	No.	Parts Name	Q'ty
①	Body	1	⑥	Collar	2
②	Swivel hook	1	⑦	Washer	2
③	Shackle	1	⑧	Securing bolt	2 (4)
④	Bolt for attaching a hook	1	⑨	Lock nut	2 (4)
⑤	Nut for attaching a hook	1			

Q'ty and dimensions inside () are for FLH2

■ Operating Method

● Installation of lifting clamp

(1) Set the width at 250mm for FLH1, and 330 for FLH2

(Align the center of fork lift to the center of the space between the forks)

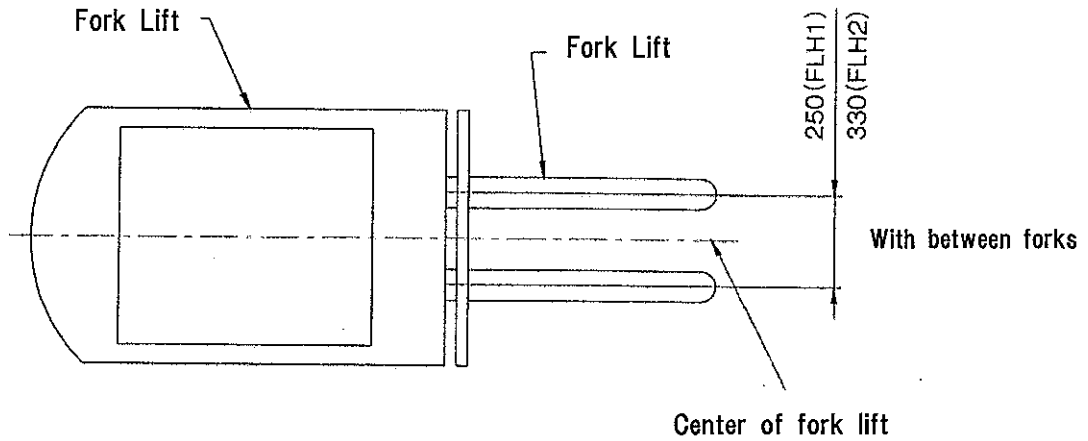

(2) Place the lifting clamp on the proper rest (sleeper etc).

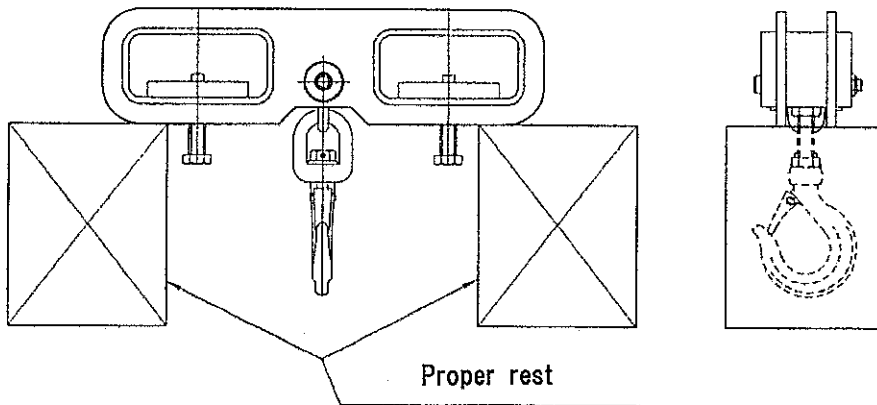

FLH1: more than 180mm in height

FLH2: more than 250mm in height

(3) Loosen securing bolts (two bolts).

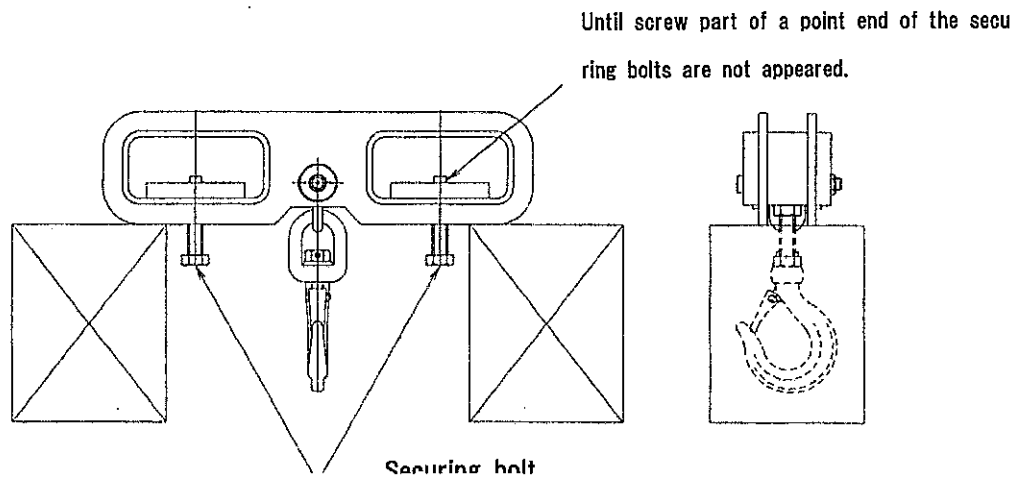

(4) Insert the forks into holes for the forks of the fork lift and position them to be fixed. (When inserting the forks, take care not to collide with the lifting clamp)

Next, raise the forks up in order to easily tighten the securing bolts.

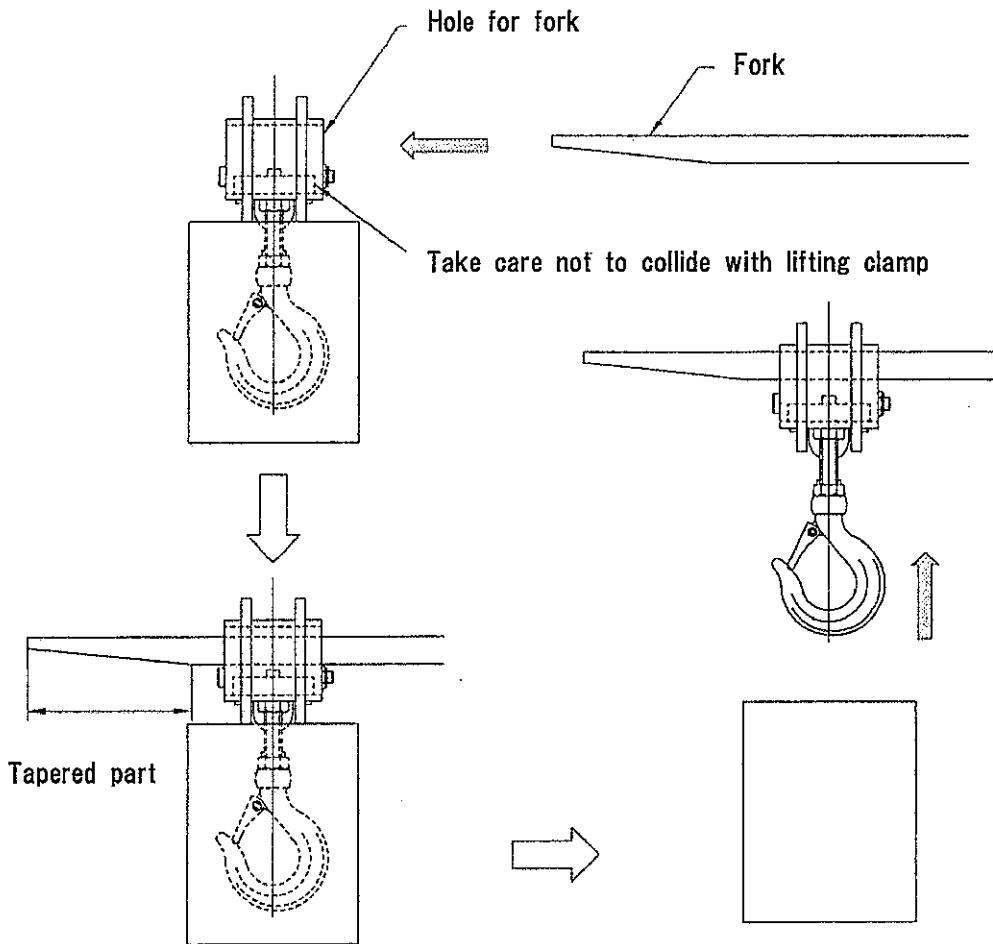

(5) Tighten the lifting clamp and forks of the fork lift by securing bolts
(The angle of the forks of the fork lift must be horizontal at this time)
Never use when the fork of the fork lift is not horizontal.

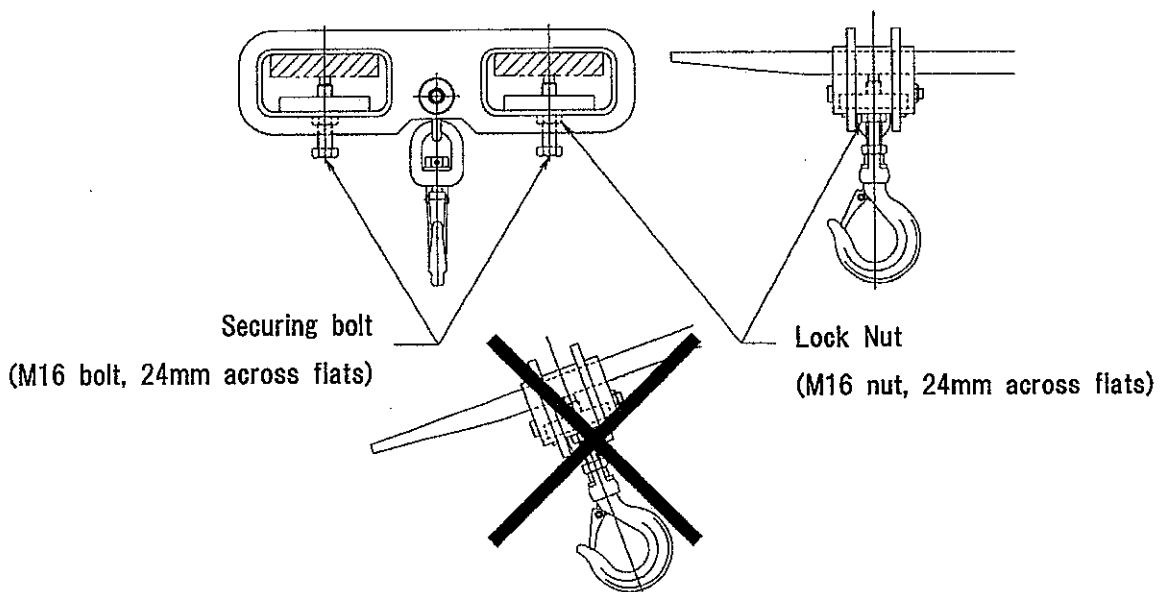

● Instruction of use

(1) Set the load (sling tool etc.) to the swivel hook of the lifting clamp.

Lift the load and move it to the destination. Read <WARNINGS> carefully.

● Removal of lifting clamp

(1) Loosen the lock nut for stopper of loosening. Next, loosen the securing bolts.

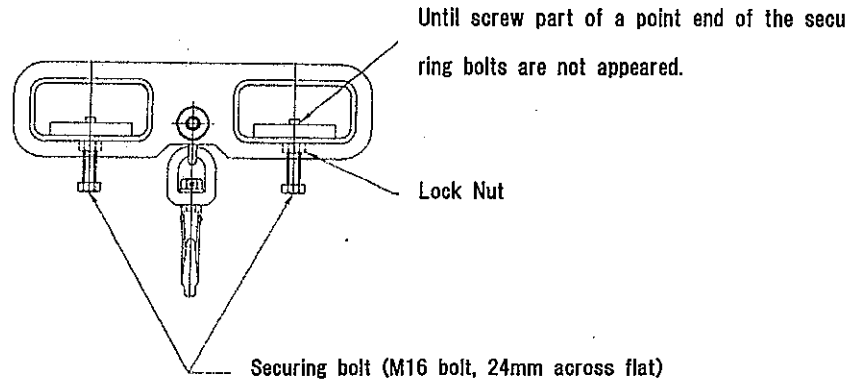

(2) Place the lifting clamp on the roper rest (sleeper etc.)

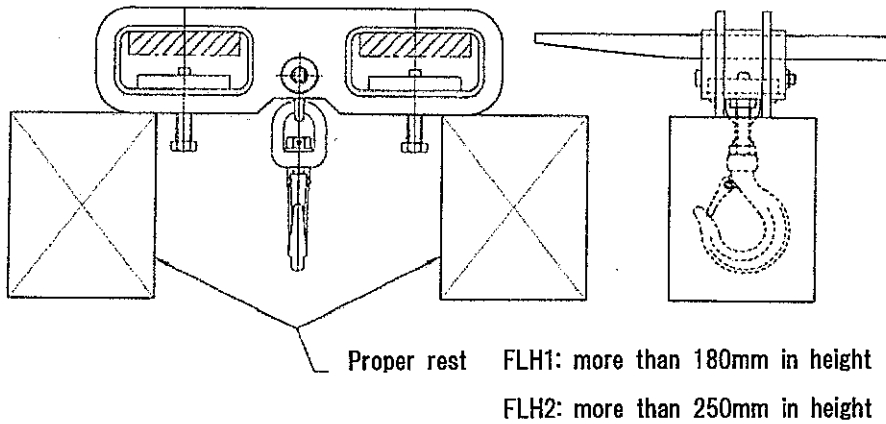

(3) Pull out the forks.

(When pulling out the forks, make sure that the fork and the lifting clamps are not caught in)

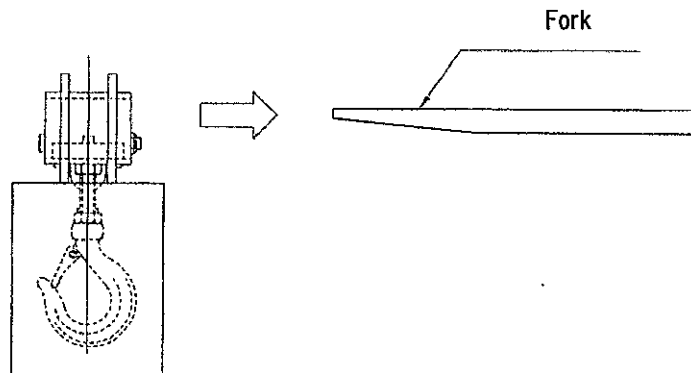

INSTRUCTIONS FOR USE

Keep these instructions within easy access of operators.

It is important that operators understand these warnings and instructions before using

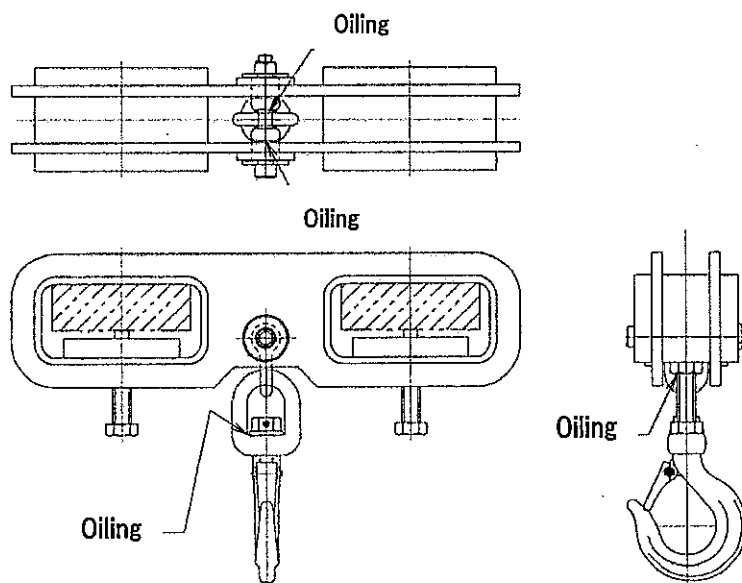

<WARNINGS>

1. The maximum rated capacity of this lifting clamp is 1 ton.
Never exceed the rated capacity of the lifting clamp.
Especially when lifting the load is caught in, the extra massive strength causes the damage of the lifting clamp.
2. Never use the lifting clamp for lateral pulling or extracting.
This lifting clamp is used only for vertical lifting.
3. Never use the forks other than the specified specifications.
4. Never drop or apply a shock to the load.
5. Never hit the lifting clamp or the load with an obstacle during lifting and transporting.
6. All personnel must stand clear of the lifting clamp and the load (within the range of the load falling down).
7. Never make a sudden start or stop during lifting and transporting.
8. When inserting and pulling out the forks, operate slowly and take care not to hit the lifting clamp with the forks.
9. When installing the lifting clamp, set it to the center of fork lift.
10. Never modify lifting clamps.
11. Oil specified points as below sometimes.
12. Check the abnormality periodically according standards for checking.

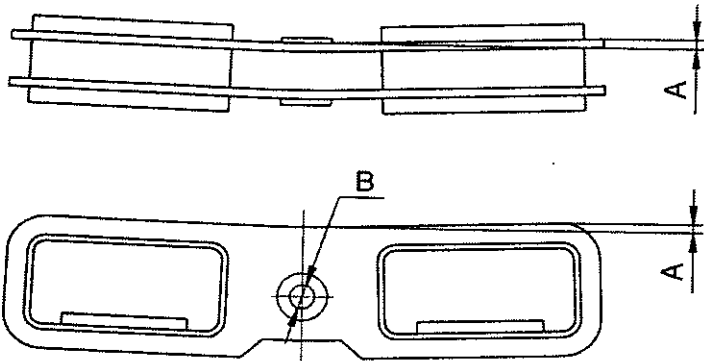
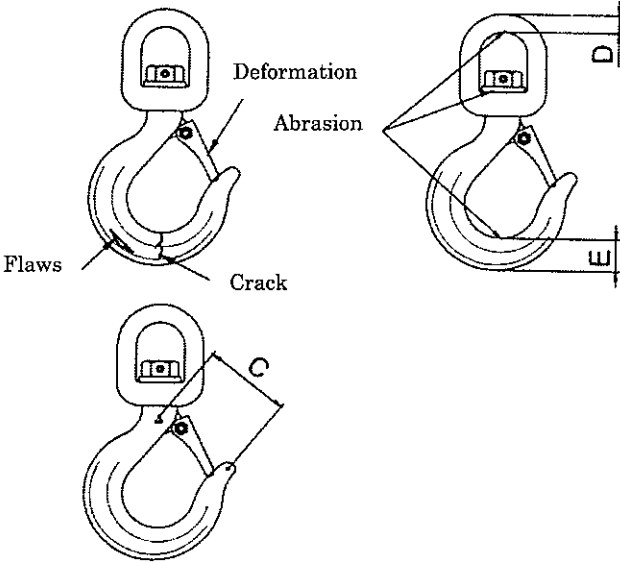

■ INSPECTION STANDARDS

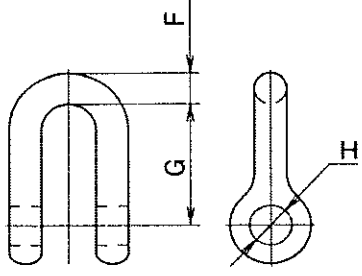
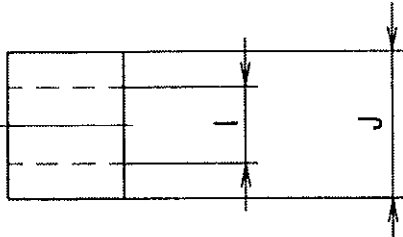
Category	Inspecting Method	Limit of use	Counter-measures
<p>Body</p> <p>Bolts and Nuts</p>	<p>● Check for deformation, cracks and flaws (visual, measuring or color checking)</p> <p>● Check for abrasion or deformation on the bolt holes. (by measuring device)</p>	<p>● When confirmed by visual checking</p>  <p>(FLH1) A: Deformation of more than 3mm B: Limit diameter of $\phi 26\text{mm}$</p> <p>(FLH2) A: Deformation of more than 3mm B: Limit diameter of $\phi 32\text{mm}$</p>	<p>Disposal</p>
<p>Swivel Hook</p>	<p>● Check for flaws, crack, deformation, and abrasion (by visual checking, measuring device, or color checking)</p> <p>● Visual checking and confirm if the latch is functioning correctly or not.</p>	 <p>(FLH1) C: Limit dimension is more than 63mm D: Limit dimension is less than 12.4mm E: Limit dimension is less than 21.9mm</p> <p>(FLH2) C: Limit dimension is more than 84mm D: Limit dimension is less than 15.2mm E: Limit dimension is less than 29.5mm</p> <p>Incorrect functioning and deformation of the latch</p>	<p>Replacement</p>

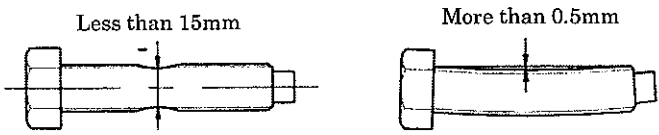
<p>Shackle</p>	<ul style="list-style-type: none"> ● Check for cracks and flaws (Visual checking or color checking) ● Abrasion at the lifting part (by measuring device) ● Deformation of the hole (by measuring device) 	<ul style="list-style-type: none"> ● When abrasion or  <p>(FLH1) F: Less than 9mm G: More than 43.2mm H: More than ϕ 13.7mm</p> <p>(FLH2) F: Less than 12.6mm G: More than 60.5mm H: More than ϕ 18.9mm</p>	<p>Replacement</p>
<p>Collar</p>	<ul style="list-style-type: none"> ● Check for abrasion or deformation (by visual check and measuring device) 	<ul style="list-style-type: none"> ● Abrasion  <p>(FLH1) I: More than ϕ 13mm J: Less than ϕ 23.5mm</p> <p>(FLH2) I: More than ϕ 18.5mm J: Less than ϕ 29.5mm</p>	<p>Replacement</p>
<p>Bolt for attaching a hook</p>	<ul style="list-style-type: none"> ● Check for abrasion or deformation (by visual check and measuring device) 	<ul style="list-style-type: none"> ● Abrasion ● Deformation  <p>(FLH1) K: Less than ϕ 11.5mm (FLH2) K: Less than ϕ 15.5mm</p>	<p>Replacement</p>
<p>Securing bolt</p>	<ul style="list-style-type: none"> ● Check for abrasion or deformation (by visual check and measuring device) 	<ul style="list-style-type: none"> ● Abrasion ● Deformation  <p>Less than 15mm</p> <p>More than 0.5mm</p>	<p>Replacement</p>