

# Lifting Clamp for Concrete Material

**CGC250 CGC500 CGC1000 (Cam Type)**  
**CGC250N CGC500N (Pad Type)**

## Operation Manual

This operation manual explain the basic usage and handling of clamps. Please do not fail to carefully read this instruction manual before use and never fail to follow each attention of usage for the proper handling of clamps.

***SUPER*TOOL**

## On the Proper Handling of Lifting Clamps with Super Tool's Mark

We are thankful to you for your selection and purchase of our Lifting Clamps with Super Tool's mark on them. Our Lifting Clamps with Super Tool's mark on them (hereinafter to be called "Lifting Clamp" or "Clamp") is energy-saving lifting tools designed and developed for transportation of steel materials and other steel products.

### **Proper use of Lifting Clamps demanded**

You are kindly asked to operate the Lifting Clamps after careful reading and understanding of this instruction manual for the purpose of enhancing safety and efficiency at work.

### **Prime efficiency and economy**

The sophisticated functions, reasonableness and wide applications of the finely and carefully designed Lifting Clamps ensure prime efficiency and economy.

### **Special care of safety**

We have executed tensile tests with loads three times (or twice) the rated capacity and attached inspection numbers to individual products, thus directing special attention to the aspect of safety.

### **Cautions for safety operation**

Please do not fail to carefully read this instruction manual before use of the Lifting Clamps.

Mistaken use of the Lifting Clamps (hereinafter to be called "Clamps") may cause troubles such as the dropping of lifted work.

Please never fail to carefully read this manual for proper operation before use.

Education of "crane safety regulations," "operation manual for lifting clamps," "in-house operation standards," etc. is to be given before actual operation not only to business owners who have purchased the Clamps but also to their operators to ensure that actual operators will have acquired enough knowledge of clamps, safety information, and cautions.

As according to the "Lifting clamp safety council," we have divided cautions in general into "Dangers" and "Cautions," which are used in this instruction manual.

**◇DANGER:** Indicates mistaken handling may cause a potentially hazardous situation which, if not avoided, could result in death or serious injury.

**△CAUTION:** Indicates mistaken handling may cause a potentially hazardous situation which, if not avoided, could result in medium damage or slight injury, or could result in property damage.

Even though only mentioned in the Cautions, those incidents may lead to a serious disaster. So, do not fail to pay attention both to dangers and cautions which are of great importance in operating the Clamps properly.

### **Meanings of Signs**

The signs of ◇ and △ indicate that attention is to be given to the marks indicative of dangers and cautions respectively. The signs figuratively show the contents of danger or caution. (The left-side sign indicates a caution to the pinching.)



The sign of indicates prohibited actions.





The sign of indicates that an action is enforced or instructed to be executed. Inside the sign or beside it is shown a concrete instruction is described.







(The left-side sign requires a lifting at two points.)

\* After reading of this manual, please keep it at a convenient place to which any user can gain easy access for reference.

### 1. About handling in general



<b>Dangers</b>	
<ul style="list-style-type: none"> <li>•Any person who is not well-informed about instruction manual, tags, and signs of cautions is not eligible for use of the Lifting Clamps.</li> <li>•Any person who is not legally qualified is never to operate a crane and a lifting clamp.</li> <li>•While lifting or turning the work, do not enter the area where the lifted work threatens to drop off or fall over.</li> <li>•Do not use this lifting clamp for other purposes than lifting work.</li> </ul>	
<ul style="list-style-type: none"> <li>•Never fail to execute an inspection before use and periodical inspections.</li> </ul>	

### 2. About checking before operation





<b>Dangers</b>	
<ul style="list-style-type: none"> <li>•Do not use a clamp other than applicable to the operation method.</li> <li>•Do not use an abnormal clamp with deformation, cracks, operational trouble, abrasion, etc.</li> <li>•If the work to lift is under the following conditions, do not apply the clamp. (fragile material, high-hardness material, low-hardness or extremely low-hardness material, and members with the large inclined gripping part and of more than 10 degrees in temperature of itself)</li> </ul>	
<ul style="list-style-type: none"> <li>•Please check on the clamp main unit the type, basically applicable load, opening diameter, and indication of periodical inspections executed.</li> <li>•The load of the work to lift shall be within the allowable range of the basically applicable load of the clamp.</li> <li>•The thickness of the work to lift shall be within the allowable clamping range.</li> </ul>	
<b>Cautions</b>	
<ul style="list-style-type: none"> <li>•Do not use the clamp with tags and signs of cautions attached to it taken away, and with them kept invisible.</li> <li>•Do not use the clamp for the work under the following conditions. (The work to lift is more than 150 degrees, is less than minus 20 degrees in temperature, and acidic or alkaline chemicals.)</li> </ul>	
<ul style="list-style-type: none"> <li>•The sling to be used for the clamp shall be an appropriate one for the lifting operation.</li> </ul>	

### 3. About the method of use and lifting operation



<b>◇Dangers</b>	
<ul style="list-style-type: none"> <li>•Do not use the Clamp, lifting at one point.</li> <li>•Do not use the Clamp in the following way of lifting: (overlapped works, padded work, engrafted lifting, concurrent lifting, and side gripping)</li> <li>•Do not use the Clamp for pulling out from among steel sheet pilings and not lift pulled-out steel sheets vertically.</li> <li>•Do not use the Clamp when strong wind threatens to cause any danger.</li> <li>•Do not use the Clamp for a hydraulic excavator.</li> </ul>	

<ul style="list-style-type: none"> <li>●Install two or more Clamps in a balanced way to keep the work' balance.</li> </ul>	
<ul style="list-style-type: none"> <li>●The lifting angle of the Clamp and the dividing angle are to be kept within the allowable angles according to types.</li> <li>●The work is to be inserted to the innermost end of the Clamp opening.</li> <li>●When you use the Clamp with a locking system, never fail to use the Clamp with the locking system on.</li> </ul>	
<p><b>△Cautions</b></p>	
<ul style="list-style-type: none"> <li>●If oil, paint, scales, rust, etc. are on the gripping pad, do not use the Clamp.</li> <li>●Do not drop to the ground or drag along the ground the Clamp.</li> </ul>	

#### 4. About the operation of a crane

<p><b>◇Dangers</b></p>	
<ul style="list-style-type: none"> <li>●Never lift the work weighing more than the basic working load.</li> <li>●Do not operate the crane in such a way as to give an impacting load to the work or the Clamp.</li> <li>●Do not allow a man to stand on the lifted work. Never use the Clamp for the purpose of carrying a man.</li> <li>●Do not lift the earth itself.</li> <li>●In the course of lifting the work, do not release the lock of the Clamp.</li> <li>●Do not let the Clamp removed from the work collide with the work or an adjacent member.</li> <li>●When you wind up the wire by the crane and notice the load at the lifting ring, stop the operation temporarily for safety checking (depth of the work into the Clamp opening; status of locking).</li> <li>●Stop the operation of the crane just before the work reaches the ground, check the following items of things: (Slant and falling over of the work; security at the landing site and its surrounding)</li> </ul>	
<ul style="list-style-type: none"> <li>●When you wind up the wire by the crane and notice the load at the lifting ring, stop the operation temporarily for safety checking (depth of the work into the Clamp opening; status of locking).</li> <li>●Stop the operation of the crane just before the work reaches the ground, check the following items of things: (Slant and falling over of the work; security at the landing site and its surrounding)</li> </ul>	
<p><b>△Cautions</b></p>	
<ul style="list-style-type: none"> <li>●Do not operate the crane in such a way as to drag the work along the ground.</li> <li>●Do not step away from the crane (winder, etc.) operating position while keeping the work being lifted with the Clamp.</li> </ul>	
<ul style="list-style-type: none"> <li>●Hoisting and lowering operation by the crane are to be made slowly and carefully.</li> </ul>	

5. About maintenance, storage and remodeling

<b>◇Dangers</b>	
<ul style="list-style-type: none"> <li>●Never execute any remodeling of the Clamp and its accessories.</li> <li>●Do not apply welding work or heating to the Clamp and its accessories.</li> <li>●Do not use any other parts than our company's brand-name parts.</li> <li>●Store at a different place Clamps requiring repairing not to be used mistakenly.</li> </ul>	
<ul style="list-style-type: none"> <li>●A person with specialized knowledge specified by the business owner is to conduct maintenance and repairing work.</li> <li>●When you detect abnormality with the Clamp, do not use it and immediately repair or dispose of it.</li> <li>●Remove, if any, paint or mud sticking to the moving parts of the Clamp, cams, and pads.</li> </ul>	
<b>△Cautions</b>	
<ul style="list-style-type: none"> <li>●Conduct maintenance and repairing with no work lifted.</li> <li>●Conduct maintenance and repairing after posting a sign indicating that you're working on the maintenance work.</li> <li>●Never fail to put lubricating oil on the rotating part of the Clamp (around the pin), guide groove, sliding parts, etc.</li> <li>●Store Clamps inside a room.</li> </ul>	

Note: Please contact our company's sales agents or sales offices to make advantage of our services in respect with items of inspections and maintenance standards accompanying disassembly and assembly.

# Lifting Clamp for Concrete Material

CGC250 CGC500 CGC1000  
CGC250N CGC500N

## ■ Applications

This is a dedicated clamp optimal for lifting and carrying reinforced concrete U-shaped gutters, U-shaped flume channels, concrete shelf boards.

## ■ Features

1. When the clamp is landed, the hook plate has the mechanism to automatically maintain the release status of the clamp which save the trouble of removing the clamp.
2. Cam teeth are made in horizontal way. When the teeth of the cams are worn down, replace cams by turning them upside down or move teeth of cams up and down, enabling them to be used 4 times. (CGC250-500-1000)
3. Pad type adopt spike mechanism which make it possible to clamp the work tightly. (CGC250N-500N)
4. Special polyurethane rubber is used for the surface of the pad. By putting back spikes, it can also be used as non-scratch pad. (CGC250N-500N)
5. By using the separately sold cam set(or pad set), the change can be made from pad type to cam type (or from cam type to pad type). (Refer to the replacement method of cams and pads)

## ■ Specification

Item No.	Rated Capacity (kg)	Jaw Opening (mm)	N.W. (kg)
CGC250	250	30~160	6
CGC500	500	30~160	12
CGC1000	1000	30~180	26
CGC250N	250	30~140	6
CGC500N	500	30~140	12

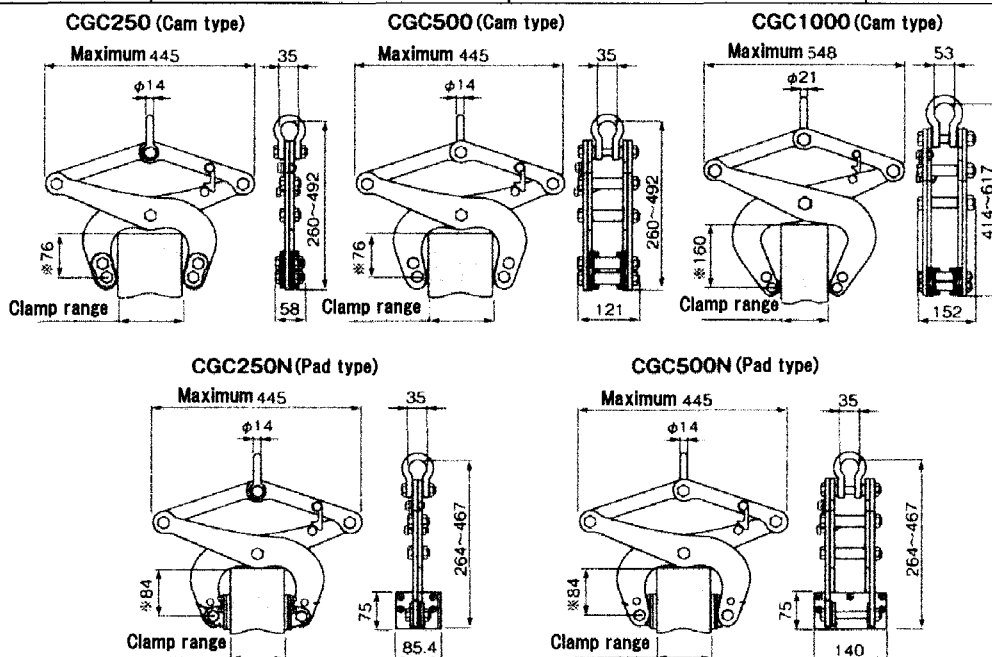

Dimension of the marked ※ is the inside depth of maximum clamp range

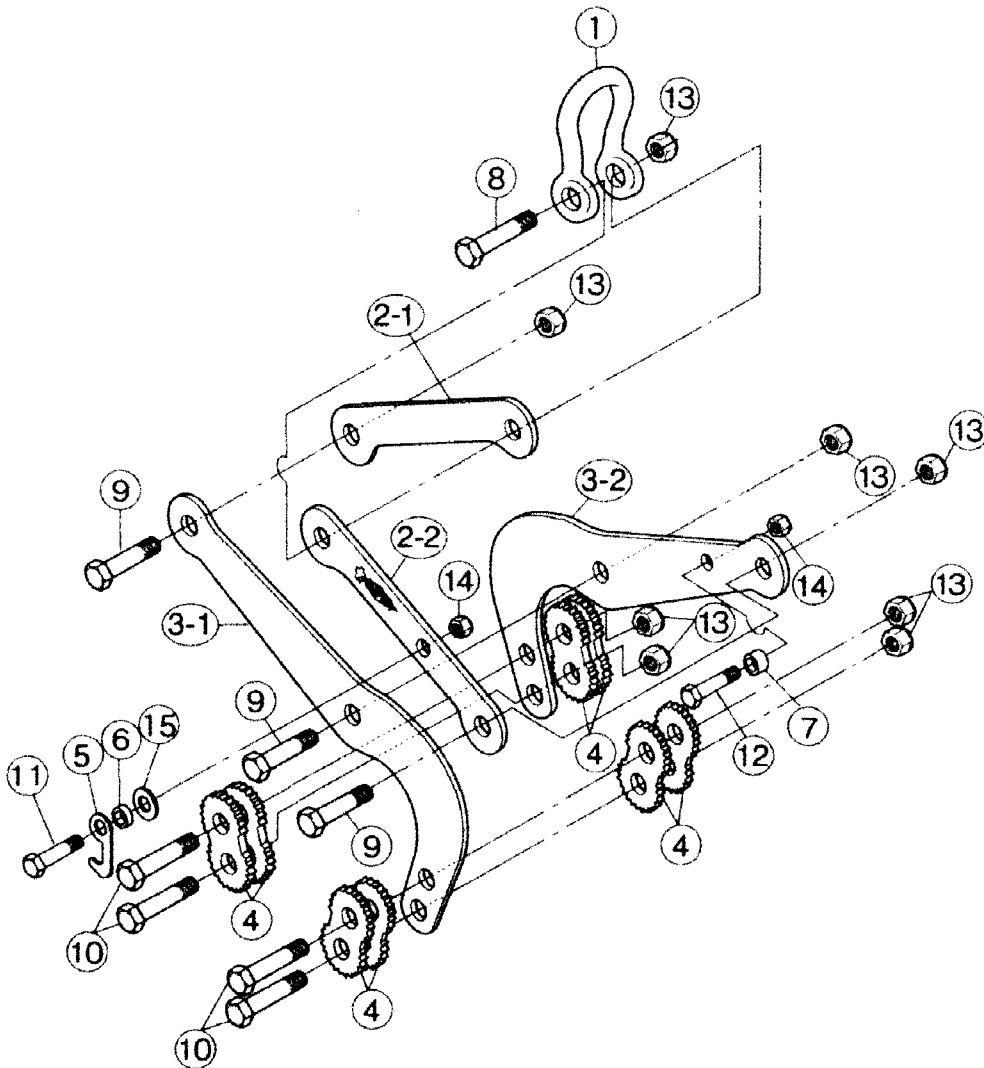

No.	Description	Item No.	Set Qty.
<b>Shackle</b>		<b>CGH250</b>	
1	Shackle	CGCH250	1
8	Hex bolt for 250 (1)	CGCA250	1
13	U Nut(1)		1
<b>Link</b>		<b>CGL250</b>	
2-1	Link (1)	CGCL250	1
※2-2	Link (2)	-	-
9	Hex bolt for 250 (2)	CGCB250	2
13	U Nut (1)		2
<b>Claw</b>		<b>CGQ250</b>	
3-1	Claw (1)	CGCQ250	1
3-2	Claw (2)	CGCR250	1
9	Hex bolt for 250 (2)	CGCC250	1
13	U Nut (1)		1

No.	Description	Item No.	Set Qty.
<b>Cam</b>		<b>CGT250</b>	
4	Cam	CGCT250	8
10	Hex bolt for 250 (3)	CGCD250	4
13	U Nut (1)		4
<b>Hook Plate</b>		<b>CGJ250</b>	
5	Hook Plate	CGCJ250	1
6	Collar for hook (1)	CGGE250	1
11	Hex bolt for hook (1)		1
14	U Nut (2)		1
15	Flat washer		1
7	Collar for hook (2)	CGCF250	1
12	Hex bolt for hook (2)		1
14	U Nut (2)		1

※2-2 Link(2) Engraved parts are not sold

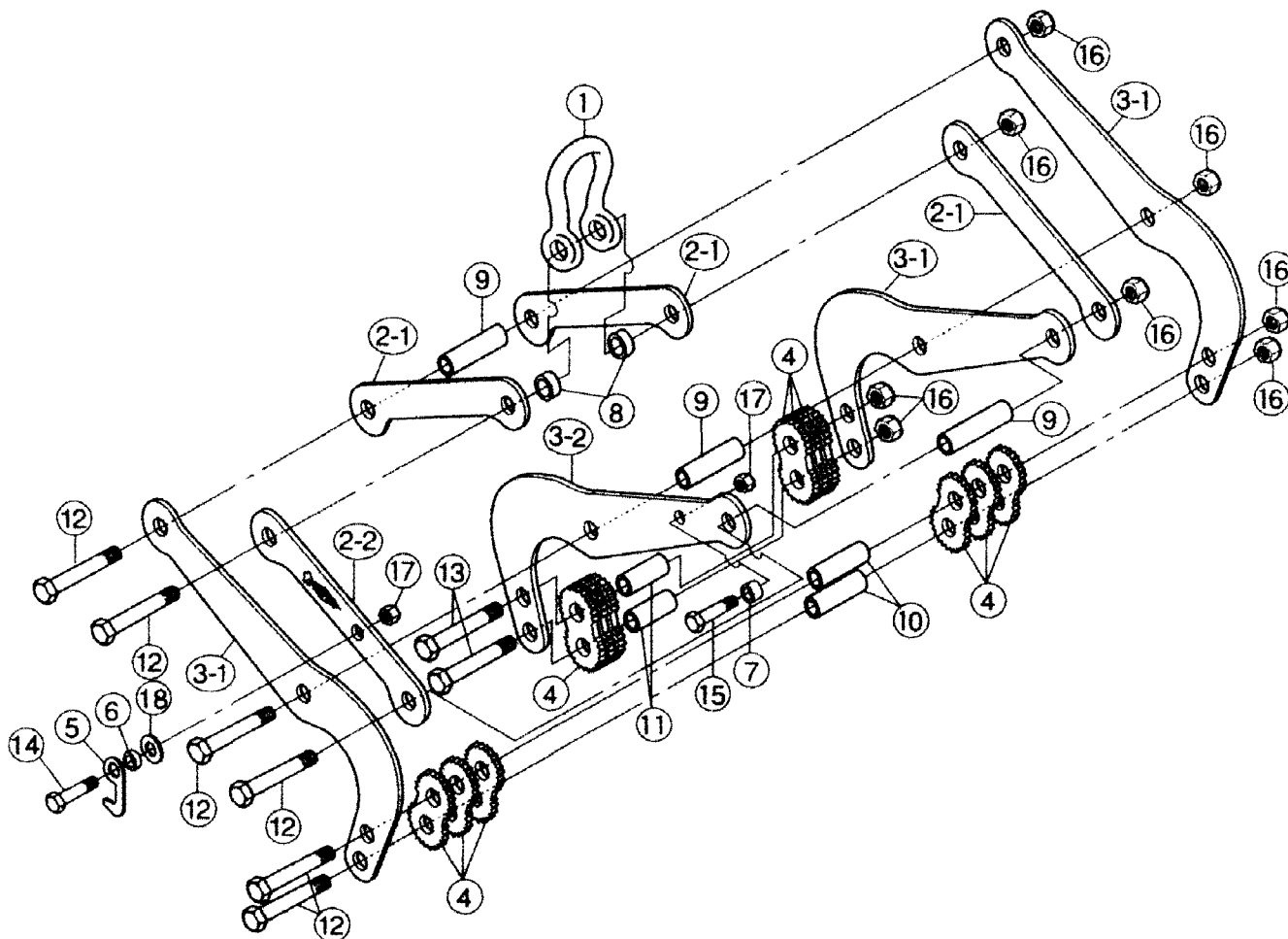

No.	Description	Item No.	Set Qty.
<b>Shackle</b>		<b>CGH500</b>	
1	Shackle	CGCH500	1
8	Collar for body (1)	CGCV500	2
12	Hex bolt for 500 (1)	CGCA500	1
16	U Nut (1)		1
<b>Link</b>		<b>CGL500</b>	
2-1	Link (1)	CGCL500	3
※2-2	Link (2)	-	-
9	Collar for body (2)	CGCW500	2
12	Hex bolt for 500 (1)	CGCB500	2
16	U Nut (1)		2
<b>Claw</b>		<b>CGQ500</b>	
3-1	Claw (1)	CGCQ500	3
3-2	Claw (2)	CGCR500	1
9	Collar for body (2)	CGCX500	1
12	Hex bolt for 500 (1)	CGCA500	1
16	U Nut (1)		1

No.	Description	Item No.	Set Qty.
<b>Cam</b>		<b>CGT500</b>	
4	Cam	CGCT500	12
10	Collar for body (3)	CGCY500	2
12	Hex bolt for 500 (1)	CGCB500	2
16	U Nut (1)		2
11	Collar for body (4)	CGCZ500	2
13	Hex bolt for 500 (2)	CGCC500	2
16	U Nut (1)		2
<b>Hook Plate</b>		<b>CGJ500</b>	
5	Hook Plate	CGCJ500	1
6	Collar for hook (1)	CGCE500	1
14	Hex bolt for hook (1)		1
17	U Nut (2)		1
18	Flat washer		1
7	Collar for hook (2)	CGCF500	1
15	Hex bolt for hook (2)		1
17	U Nut (2)		1

※2-2 Link(2) Engraved parts are not sold



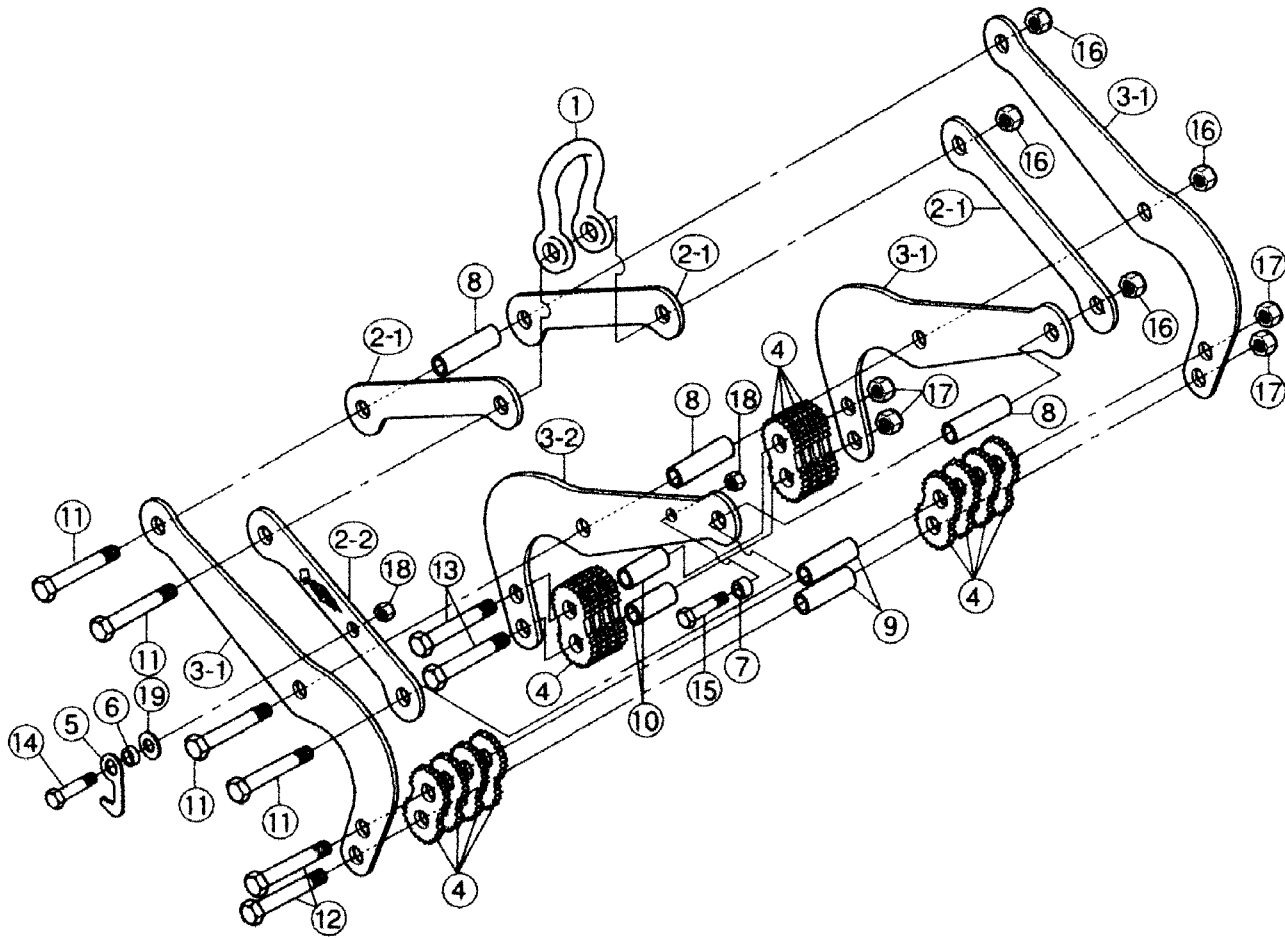

No.	Description	Item No.	Set Qty.
<b>Shackle</b>		<b>CGH1000</b>	
1	Shackle	CGCH1000	1
11	Hex bolt for body (1)	CGCA1000	1
16	U Nut (1)		1
<b>Link</b>		<b>CGL1000</b>	
2-1	Link (1)	CGCL1000	3
※2-2	Link (2)	-	-
8	Collar for body (1)	CGCW1000	2
11	Hex bolt for body (1)	CGCB1000	2
16	U Nut (1)		2
<b>Claw</b>		<b>CGQ1000</b>	
3-1	Claw (1)	CGCQ1000	3
3-2	Claw (2)	CGCR1000	1
8	Collar for body (1)	CGCX1000	1
11	Hex bolt for body (1)	CGCA1000	1
16	U Nut (1)		1

No.	Description	Item No.	Set Qty.
<b>Cam</b>		<b>CGT1000</b>	
4	Cam	CGCT1000	16
9	Collar for body (2)	CGCY1000	2
12	Hex bolt for body (2)	CGCC1000	2
17	U Nut (2)		2
10	Collar for body (3)	CGCZ1000	2
13	Hex bolt for body (3)	CGCD1000	2
17	U Nut (2)		2
<b>Hook Plate</b>		<b>CGJ1000</b>	
5	Hook Plate	CGCJ1000	1
6	Collar for hook (1)	CGCE1000	1
14	Hex bolt for hook (1)		1
18	U Nut (3)		1
19	Flat washer		1
7	Collar for hook (2)	CGCF1000	1
15	Hex bolt for hook (2)		1
18	U Nut (3)		1

※2-2 Link(2) Engraved parts are not sold

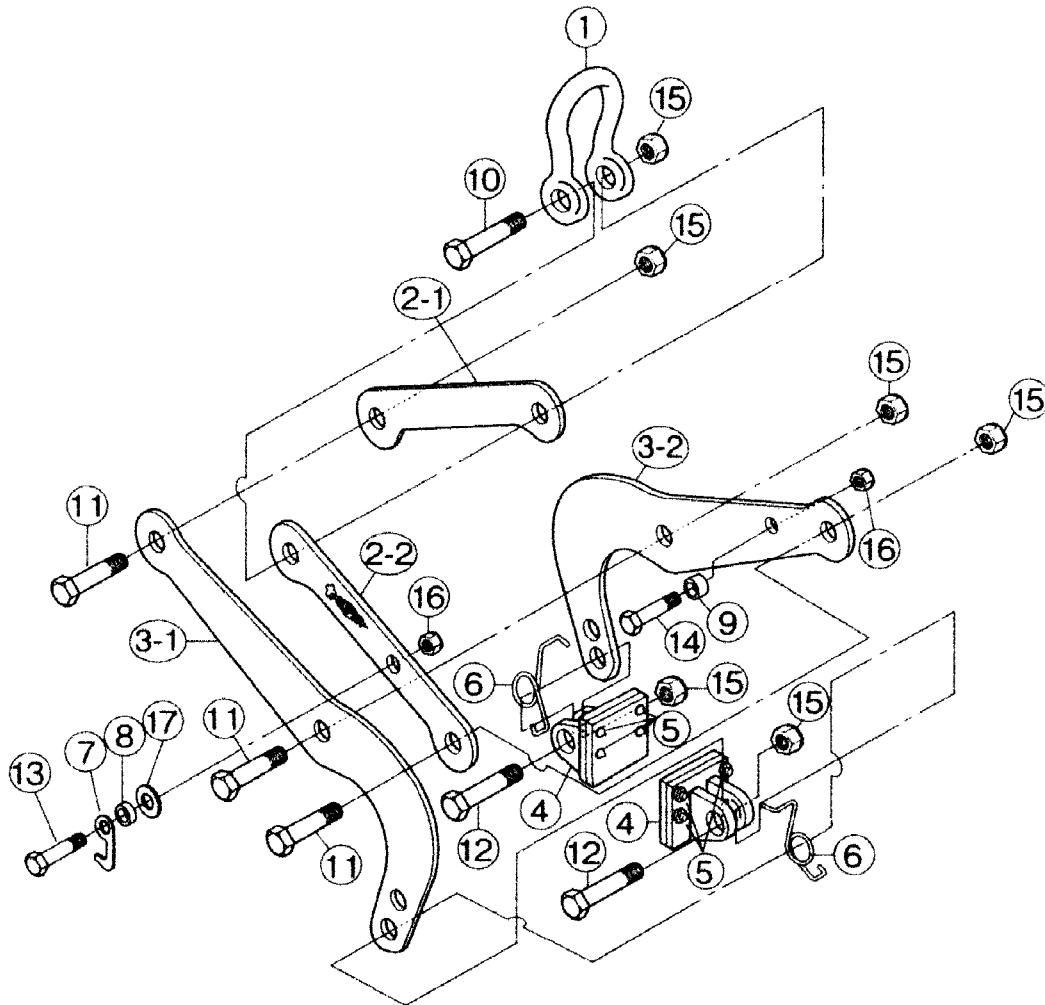

No.	Description	Item No.	Set Qty.
<b>Shackle</b>		<b>CGH250N</b>	
1	Shackle	CGCH250N	1
10	Hex bolt for 250 (1)	CGCA250N	1
15	U Nut (1)		1
<b>Link</b>		<b>CGL250N</b>	
2-1	Link (1)	CGCL250N	1
※2-2	Link (2)	-	-
11	Hex bolt for 250 (2)	CGCB250N	2
15	U Nut (1)		2
<b>Claw</b>		<b>CGQ250N</b>	
3-1	Claw (1)	CGCQ250N	1
3-2	Claw (2)	CGCR250N	1
11	Hex bolt for 250 (2)	CGCC250	1
15	U Nut (1)		1

No.	Description	Item No.	Set Qty.
<b>Pad</b>		<b>CGP250N</b>	
4	Pad	CGCP250N	2
5	Spike-Hex Nut	CGCN250N	8
6	Spring	CGCM250N	2
12	Hex bolt for 250 (3)	CGCD250N	2
15	U Nut (1)		2
<b>Hook Plate</b>		<b>CGJ250N</b>	
7	Hook plate	CGCJ250N	1
8	Collar for hook (1)	CGCE250N	1
13	Hex bolt for hook (1)		1
16	U Nut (2)		1
17	Flat washer		1
9	Collar for hook (2)	CGCF250N	1
14	Hex bolt for hook (2)		1
16	U Nut (2)		1

※2-2 Link(2) Engraved parts are not sold

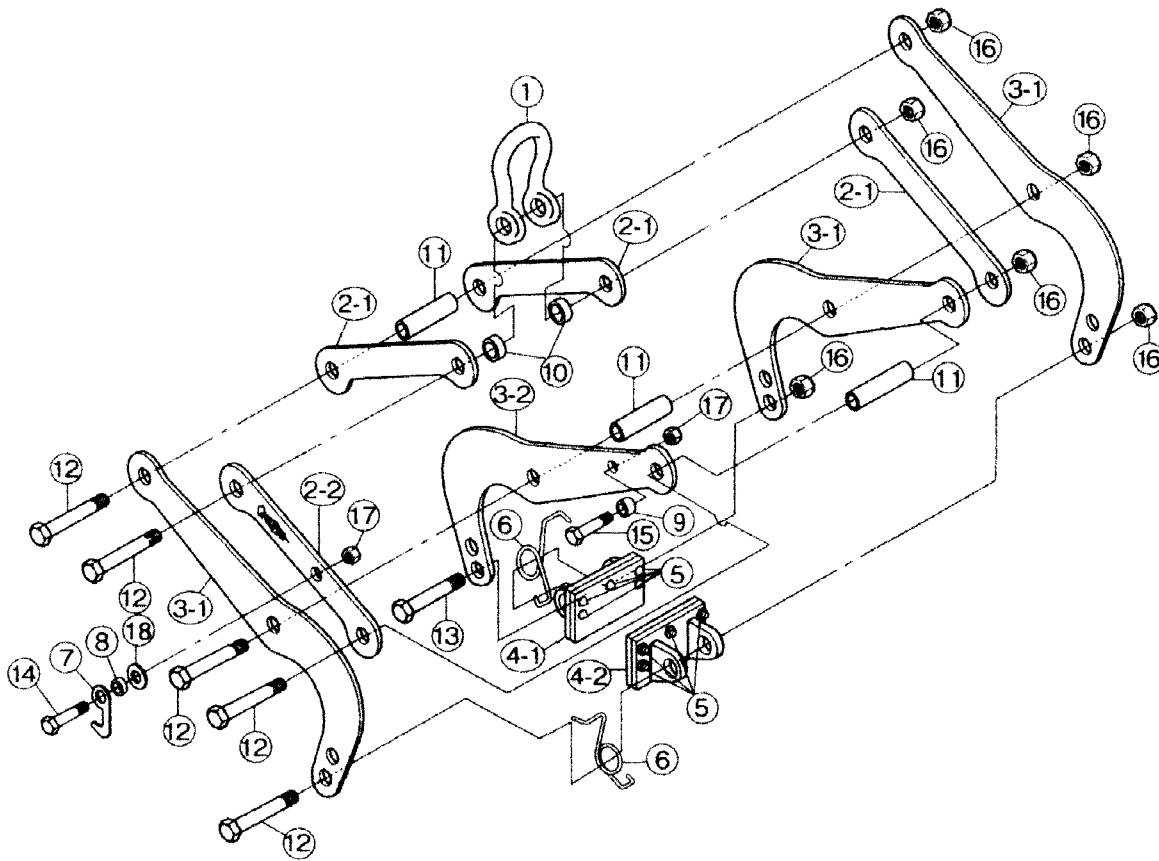

No.	Description	Item No.	Set Qty.
<b>Shackle</b>		<b>CGH500N</b>	
1	Shackle	CGCH500N	1
10	Collar for body (1)	CGCV500N	2
12	Hex bolt for 500 (1)	CGCA500N	1
16	U Nut (1)		1
<b>Link</b>		<b>CGL500N</b>	
2-1	Link (1)	CGCL500N	3
※2-2	Link (2)	-	-
11	Collar for body (2)	CGCW500N	2
12	Hex bolt for 500 (1)	CGCB500N	2
16	U Nut (1)		2
<b>Claw</b>		<b>CGQ500N</b>	
3-1	Claw (1)	CGCQ500N	3
3-2	Claw (2)	CGCR500N	1
11	Collar for body (2)	CGCX500N	1
12	Hex bolt for 500 (1)	CGCA500N	1
16	U Nut (1)		1

No.	Description	Item No.	Set Qty.
<b>Pad</b>		<b>CGP500N</b>	
4-1	Pad (1)	CGCP500N	1
4-2	Pad (2)		1
5	Spike -Hex Nut	CGCN500N	10
6	Spring	CGCM500N	2
12	Hex bolt for 500 (1)	CGCA500N	1
16	U Nut (1)		1
13	U Nut (1)	CGCC500N	1
16	U Nut (1)		1
<b>Hook Plate</b>		<b>CGJ500N</b>	
7	Hook Plate	CGCJ500N	1
8	Collar for hook (1)	CGCE500N	1
14	Hex bolt for hook (1)		1
17	U Nut (2)		1
18	Flat Washer		1
9	Collar for hook (2)	CGCF500N	1
15	Hex bolt for hook (2)		1
17	U Nut (2)		1

※2-2 Link(2) Engraved parts are not sold

## Operational Procedures

### 1. Operating Method

Strictly observe to hoist by 2 point and carry out the same operation.

- (1) Apply the clamp dedicated for lifting concrete products (hereafter called "clamp") on the crane hook by using wire rope. In the mean time, keep the clamp under the release status by hanging hook plate. (Table. 1)
- (2) Lift up the clamp of the release status and move the clamp to the work. When use two clamps at the same time, be careful not to get the clamps collide with each other or not to have the wire rope twisted.
- (3) Lower the clamps to touch the works. Turn the hook plate backward to put the clamp into the lifting status. As you wind up the crane hook, the work can be lifted up. (Table 2)

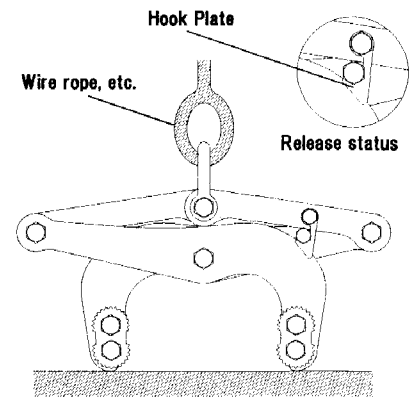

Table.1

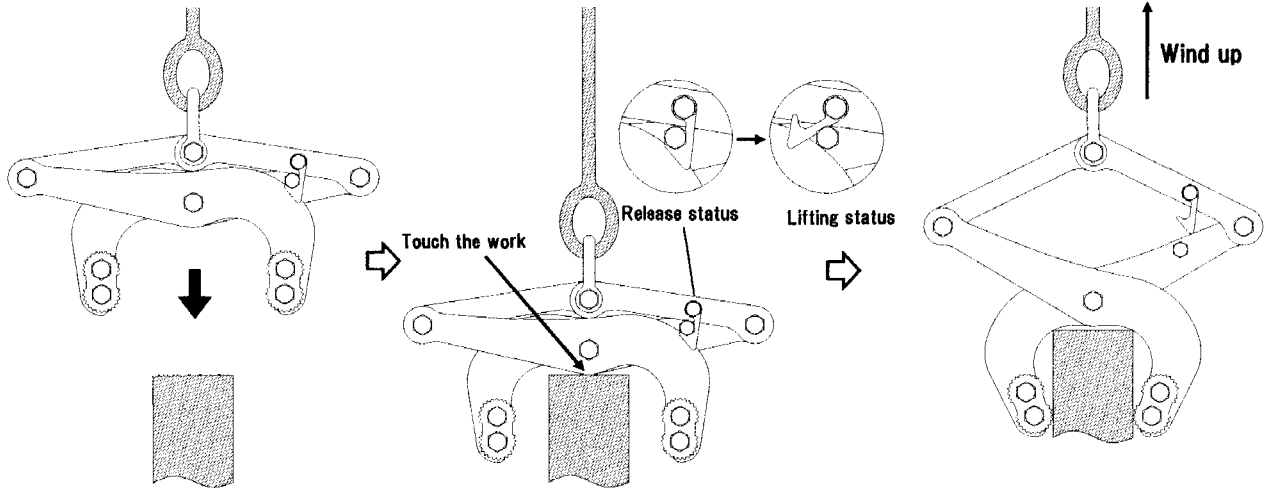
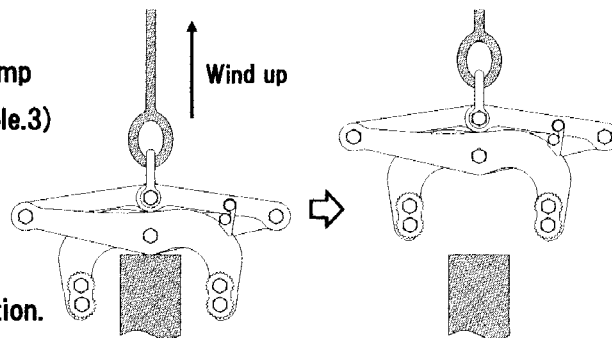

Table.2

- (4) After confirming that the work is being lifted up smoothly and stably, move the work to a destination.
- (5) Upon arrival at the destination, lower and land the work. Confirm that the work is landed in a well-balanced manner. In addition, the hook plate is then designed to be automatically locked. If not, lock it with your own hand.

- (6) When winding up the crane hook, only the clamp under the release status will be lifted up. (Table.3)



- (7) Return to Item 2 of Operational Procedures for repetitive use when doing the same operation.

Table. 3

## 2. Replacement Procedure for Cam

### (1) Disassembling and reassembling of Cam (Replacement procedure of used parts)

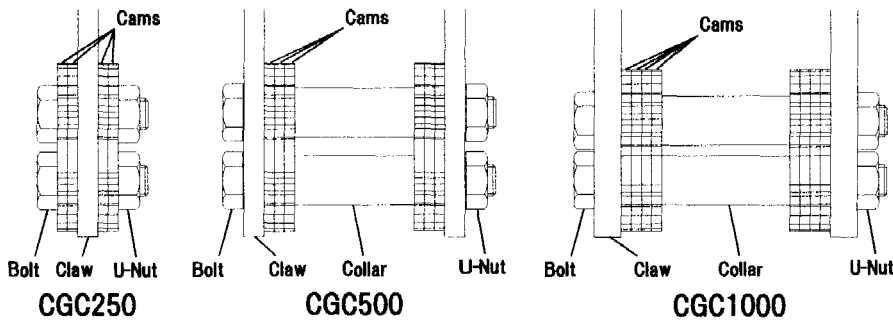

Table. 4

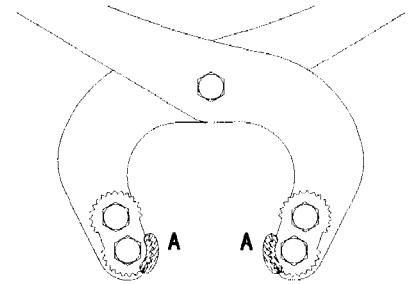

Table5

- ① Disassemble cams by loosening bolt and U-Nut. (Table. 4)
- ② Replace cams by turning them upside down or move up and down so that non-used part can be placed on A of table 5. Refer to page 7 to 9 for replacing position of the cams.  
 ※Pad can also be attached(CGC250-500) (Refer to pad replacement method)
- ③ Tighten bolt and U nut.

### (2) Disassembling and reassembling of Pads

- ① Loosen the fixing bolts and nuts, then remove the springs and the old pad (Table.6)
- ② Attach new pad and springs onto the claws  
 Refer to page 10 to 11 for replacing the position of the pads.  
 ※Cam also can be attached  
 (Refer to cam replacement method)

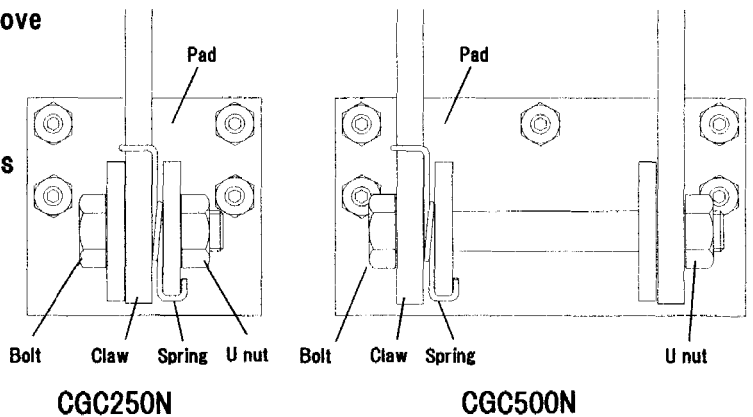

Table. 6

- ③ Fasten bolt and U nut

### (3) Spike Adjustment / Replacement Method

When the pad is used as non-scratching pad, or spike is worn out, the pads need to be adjusted or replaced.

- ① Loosen hex nut and turn spike by hex wrench or by screw driver for adjustment and replacement. (Table.7)
- ② Fasten the hex nuts

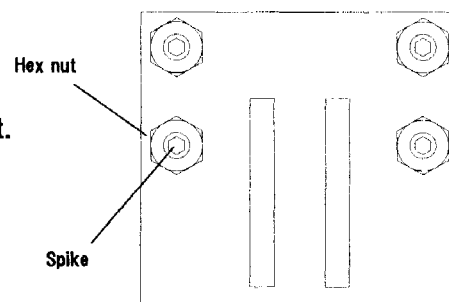
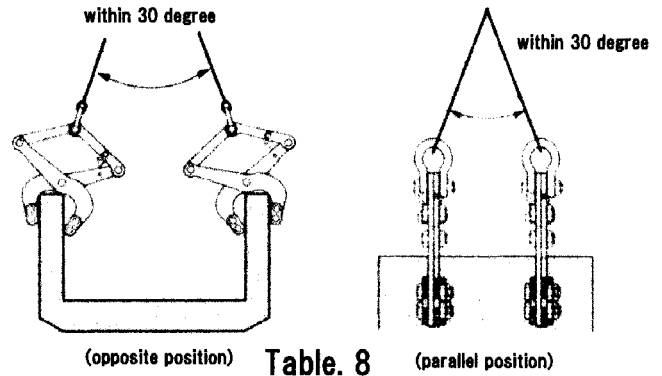

Table. 7

## Cautions

- When clamping the work at two points, try to use the balancer and lift it vertically. In addition, if the balancer cannot be used, set the clamping and lifting angle at the specified angles shown in the figures.



- The work is in principle to be lifted up vertically, and not to be pulled sideways. Otherwise, clamping power cannot be applied to the work.

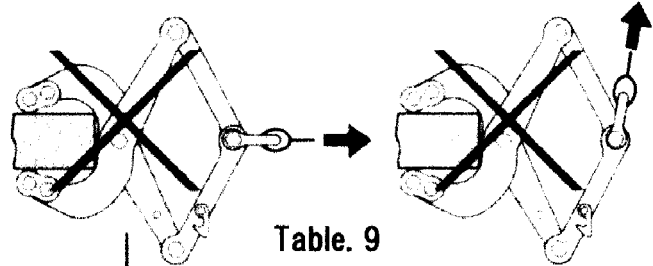

- Piled U-shaped gutters, concrete boards, etc. must not be lifted

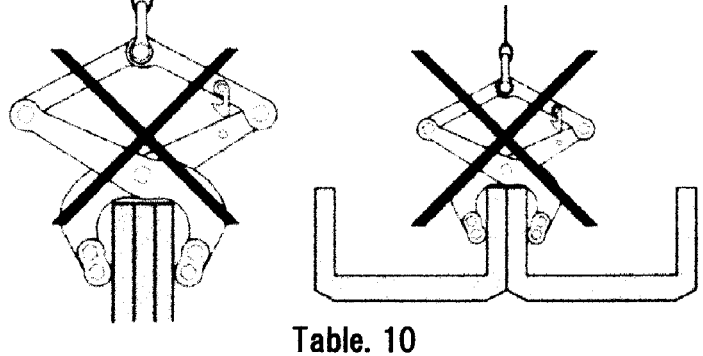

- Clamping a point apart from the gravity point of the work may cause a displacement of the gripping position, causing a danger. (Remember to clamp the work by two points to keep the balance.)

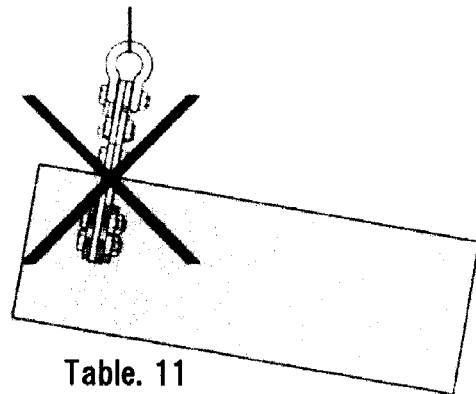

- The following lifting must be avoided. (Table.12)
  - Pulling out of a U-shaped gutter buried underground.
  - Piled-up U-shaped gutters

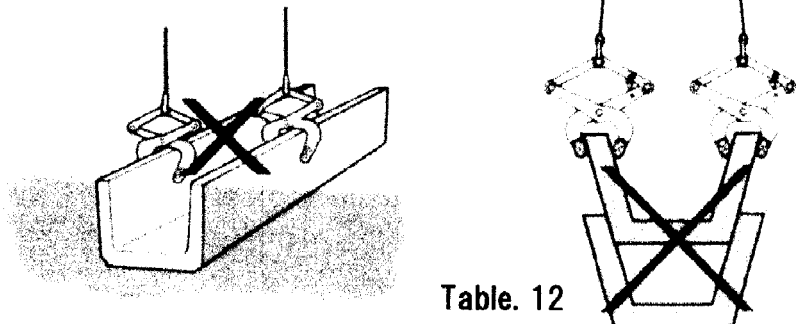

- Before lifting the work, check for the status of the clamp.

## Attention

- ◆ Never fail to check before use for detachment and the level of abrasion of the polyurethane rubber pads and abnormalities with any other parts.
- ◆ Do not use clamp of other than concrete products.
- ◆ Use this unit within the allowable load weight.
- ◆ Apply this unit only for boards of the allowable thicknesses (within the clamping ranges).
- ◆ Do not enter the area where the lifted work may drop.
- ◆ Do not give any impact to the work or the lifting clamp.
- ◆ Avoid any abrupt movement or sudden stop.
- ◆ Do not apply this unit to concrete products under curing.
- ◆ Do not remodel the unit. Application of heat and any modification may cause a substantial degrading of The quality (strength) of the Unit.
- ◆ When water, oil, sands, ice, or snow is on the surface of the concrete products to lift, there threatens to be a slipping accident. Never fail to remove any of them from the concrete products.

## Others

### 1. Inquiries for spare parts and repair.

In case of spare parts and repair to be needed, stop using clamps and contact our main or each sales office shown on the backside.

### 2. Liability Insurance Policy

Under the normal use of condition of this clamp, we have insurance policy to pay damage caused by the defective quality. (Only within the range of insured amount)

Pay attention that the following cases are not to be covered for insurance.





- (1) In case of lifting up more than the rated capacity limit.
- (2) In case of mishandling or user's self-determined method of repair or conversion.

## Daily Inspection

To prevent the deterioration of operation safety and efficiency, carry out daily inspection and maintenance.

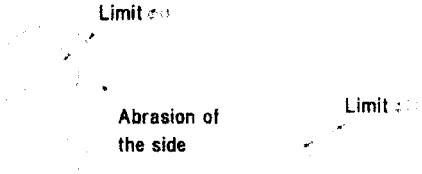
1. Check if the body and each parts of cams or shackle do not have scratch or crack.
2. Check if the bolts and nuts are assembled in a good condition.
3. Check if each parts operate in a good condition.
4. Check if cams and pads do not have wear or defectives and also check if the tip of teeth are not clogged.
5. Refer to the inspection criteria for other inspection points,

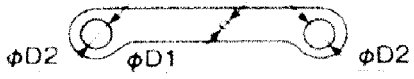
■ INSPECTION STANDARDS

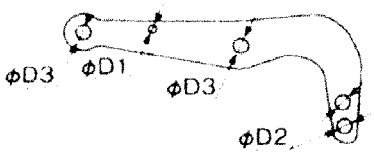
Category	Inspecting Method	Limit of use	Counter-measures												
Shackle	<ul style="list-style-type: none"> <li>● Check for flaws or cracks (by visual check or color check)</li> <li>● Check wear or deformation on lifted part and on screw holes. (by measuring device)</li> </ul>	<ul style="list-style-type: none"> <li>● When confirmed by visual checking</li> <li>● When hole diameter, even one part of circumference exceeds the size as per the below table.</li> </ul> <table border="1" data-bbox="577 360 1305 461"> <tr> <td>Item No.</td> <td>CGC250-500-250N-500N</td> <td>CGC1000</td> </tr> <tr> <td>d(mm)</td> <td>Less than 13 (standard <math>\phi</math> 14)</td> <td>Less than 20 (standard <math>\phi</math> 21)</td> </tr> <tr> <td>D(mm)</td> <td>More than 17 (standard <math>\phi</math> 16)</td> <td>More than 23 (standard <math>\phi</math> 22)</td> </tr> </table> 	Item No.	CGC250-500-250N-500N	CGC1000	d(mm)	Less than 13 (standard $\phi$ 14)	Less than 20 (standard $\phi$ 21)	D(mm)	More than 17 (standard $\phi$ 16)	More than 23 (standard $\phi$ 22)	Replacement			
Item No.	CGC250-500-250N-500N	CGC1000													
d(mm)	Less than 13 (standard $\phi$ 14)	Less than 20 (standard $\phi$ 21)													
D(mm)	More than 17 (standard $\phi$ 16)	More than 23 (standard $\phi$ 22)													
Bolts and Nuts	<ul style="list-style-type: none"> <li>● Check for abrasion or deformation on the axial part (by measuring device)</li> <li>● Check for deflection or deformation. (by visual check or measuring device)</li> <li>● Check whether the assembled condition of nuts is good or not. (by visual check)</li> </ul>	<ul style="list-style-type: none"> <li>● When the diameter of axis, even one part of circumference become less than the size of below table.</li> </ul> <table border="1" data-bbox="577 750 1171 817"> <tr> <td>Threads Size</td> <td>M10</td> <td>M14</td> <td>M20</td> </tr> <tr> <td>D(mm)</td> <td>9.5</td> <td>13.5</td> <td>19.5</td> </tr> </table> <ul style="list-style-type: none"> <li>● When confirmed deflection or deformation of more than 0.5mm</li> <li>● When found breakage, loose, or detachment</li> </ul> 	Threads Size	M10	M14	M20	D(mm)	9.5	13.5	19.5	Replacement				
Threads Size	M10	M14	M20												
D(mm)	9.5	13.5	19.5												
Link	<ul style="list-style-type: none"> <li>● Check for deflection or deformation. (by visual ckeck or measuring device)</li> <li>● Check for abrasion or deformation of pin hole (by measuring device)</li> </ul>	<ul style="list-style-type: none"> <li>● When confirmed deflection or deformation of more than 1mm</li> </ul>  <ul style="list-style-type: none"> <li>● When hole diameter, even one part of circumference exceeds the size as per the below table.</li> </ul> <table border="1" data-bbox="577 1332 1305 1433"> <tr> <td>Item No.</td> <td>CGC250-500-250N-500N</td> <td>CGC1000</td> </tr> <tr> <td>D1(mm)</td> <td>Less than 11 (standard <math>\phi</math> 10.5)</td> <td>Less than 11 (standard <math>\phi</math> 10.5)</td> </tr> <tr> <td>D2(mm)</td> <td>More than 15 (standard <math>\phi</math> 14.5)</td> <td>More than 21 (standard <math>\phi</math> 20.5)</td> </tr> </table> 	Item No.	CGC250-500-250N-500N	CGC1000	D1(mm)	Less than 11 (standard $\phi$ 10.5)	Less than 11 (standard $\phi$ 10.5)	D2(mm)	More than 15 (standard $\phi$ 14.5)	More than 21 (standard $\phi$ 20.5)	<p>Replace the link of no mark.</p> <p>Dispose the hoist tool with mark.</p>			
Item No.	CGC250-500-250N-500N	CGC1000													
D1(mm)	Less than 11 (standard $\phi$ 10.5)	Less than 11 (standard $\phi$ 10.5)													
D2(mm)	More than 15 (standard $\phi$ 14.5)	More than 21 (standard $\phi$ 20.5)													
Arm	<ul style="list-style-type: none"> <li>● Check for deflection or deformation. (by visual ckeck or measuring device)</li> <li>● Check for abrasion or deformation of pin hole (by measuring device)</li> </ul>	<ul style="list-style-type: none"> <li>● When confirmed deflection or deformation of more than 1mm</li> </ul>  <ul style="list-style-type: none"> <li>● When hole diameter, even one part of circumference exceeds the size as per the below table.</li> </ul> <table border="1" data-bbox="577 1814 1305 1944"> <tr> <td>Item No.</td> <td>CGC250-500-250N-500N</td> <td>CGC1000</td> </tr> <tr> <td>D1(mm)</td> <td>11 (standard <math>\phi</math> 10.5)</td> <td>11 (standard <math>\phi</math> 10.5)</td> </tr> <tr> <td>D2(mm)</td> <td>15 (standard <math>\phi</math> 14.5)</td> <td>15 (standard <math>\phi</math> 14.5)</td> </tr> <tr> <td>D3(mm)</td> <td>15 (standard <math>\phi</math> 14.5)</td> <td>21 (standard <math>\phi</math> 20.5)</td> </tr> </table> 	Item No.	CGC250-500-250N-500N	CGC1000	D1(mm)	11 (standard $\phi$ 10.5)	11 (standard $\phi$ 10.5)	D2(mm)	15 (standard $\phi$ 14.5)	15 (standard $\phi$ 14.5)	D3(mm)	15 (standard $\phi$ 14.5)	21 (standard $\phi$ 20.5)	Replacement
Item No.	CGC250-500-250N-500N	CGC1000													
D1(mm)	11 (standard $\phi$ 10.5)	11 (standard $\phi$ 10.5)													
D2(mm)	15 (standard $\phi$ 14.5)	15 (standard $\phi$ 14.5)													
D3(mm)	15 (standard $\phi$ 14.5)	21 (standard $\phi$ 20.5)													

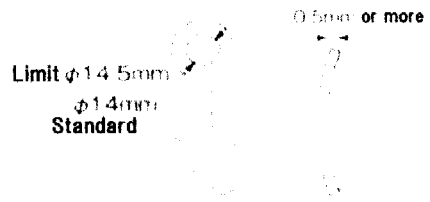
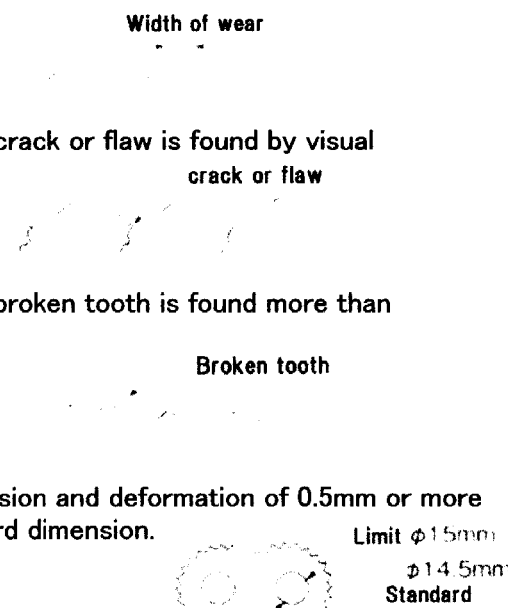
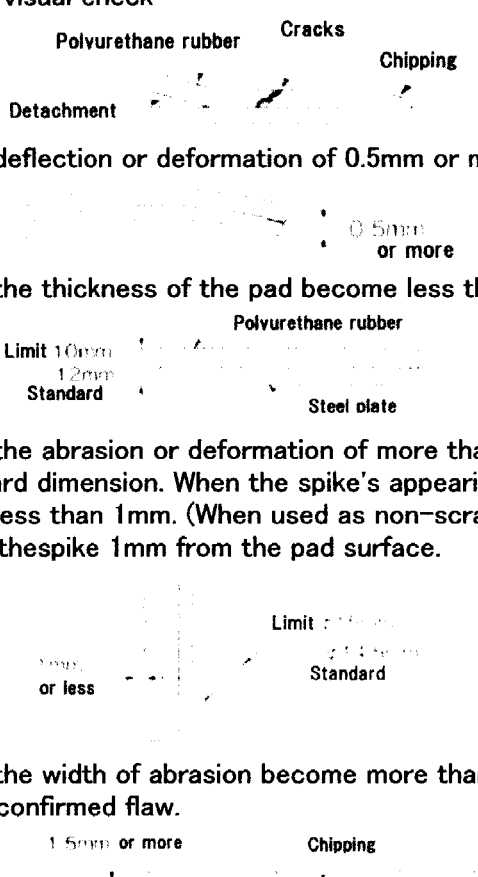

Hook Plate	<ul style="list-style-type: none"> <li>● Check for deflection or deformation. (by visual check or measuring device)</li> <li>● Check for abrasion or deformation of pin hole (by measuring device)</li> </ul>	<ul style="list-style-type: none"> <li>● When confirmed deflection or deformation of more than 0.5mm</li> <li>● When abrasion or deformation become more than 0.5mm of standard dimension</li> </ul> 	Replacement
Cam	<ul style="list-style-type: none"> <li>● Check for amount of wear on the edge part (by visual check or measuring device)</li> </ul>	<ul style="list-style-type: none"> <li>● When the amount of wear exceeds 0.5mm.</li> <li>● When the crack or flaw is found by visual</li> <li>● When the broken tooth is found more than one part</li> <li>● When abrasion and deformation of 0.5mm or more than standard dimension.</li> </ul> 	Replacement
Pads	<ul style="list-style-type: none"> <li>● Check for cracks and detachment of the polyurethane rubber (by visual check)</li> </ul>	<ul style="list-style-type: none"> <li>● When cracks or detachment or chippings are found by visual check</li> <li>● When deflection or deformation of 0.5mm or more is found</li> <li>● When the thickness of the pad become less than 10mm</li> <li>● When the abrasion or deformation of more than 0.5mm of standard dimension. When the spike's appearing height become less than 1mm. (When used as non-scratching pad, pull the spike 1mm from the pad surface.)</li> <li>● When the width of abrasion become more than 1.5mm or when confirmed flaw.</li> </ul> 	Replacement
Spring	<ul style="list-style-type: none"> <li>● Check for deformation or extension (by visual check)</li> </ul>	<ul style="list-style-type: none"> <li>● When cracks or detachment or chippings are</li> <li>● When confirmed not enough resilience</li> </ul>	Replacement