

» Convenient for Steel Plate Lifting

HPC-N

HORIZONTAL LIFTING CLAMP

CHECK!



Operation manual & parts drawing

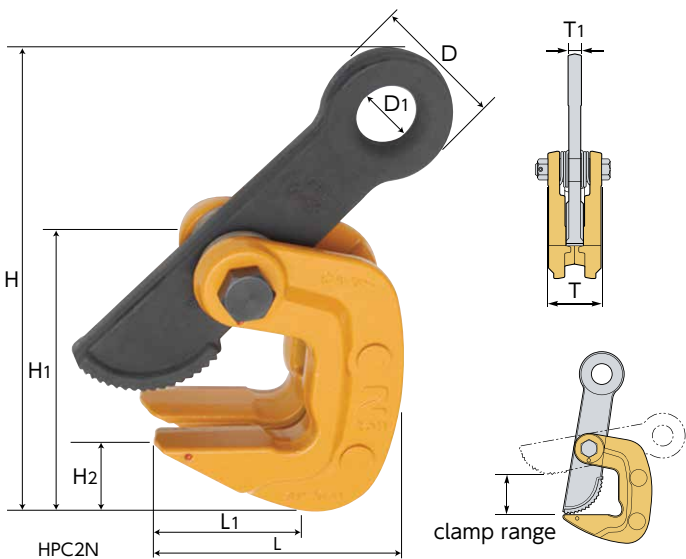

Example of use

⚠ Always lift a load at 2 or more points for safety.

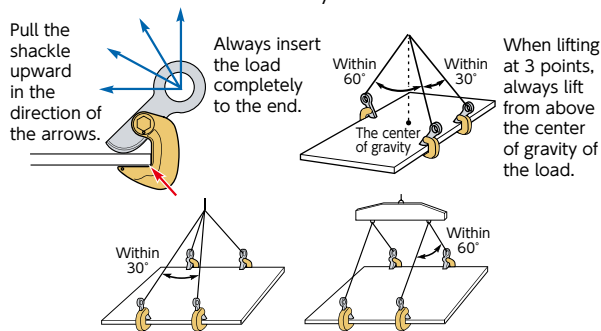

When lifting a long load, lift at 4 or more points, and use a balance whenever possible. (for safe operation, the lifting angle of the sling ropes must be kept within the specified angles.)

Features

- For lateral (horizontal) lifting of steel plates, flat steel bars, H beams, etc.
- With the spring mechanism, it is unnecessary to hold the clamp after setting it onto the load. And when the load lands on the floor, the initial clamp force assures that the clamp does not come off.

Item No.	Rated capacity (ton)	Clamp range (mm)	Size (mm)										N.W. (kg)
			L	L1	H(MAX)	H1	H2	D	D1	T	T1		
HPC0.5N	0.5	0~35	82.5	51.5	170	96.5	25	40	18	40	10	0.9	
HPC1N	1	0~40	98	59	204	117	32	50	23	51	13	1.8	
HPC2N	2	0~50	125	73	268	152.5	33	67	30	67	17	4.0	
HPC3N	3	0~60	150	88	329	181	51	82	36	80	22	6.8	
HPC5N	5	0~80	195	117	415	236	66	101	46	102	28	15	

Vertical & lateral lifting clamps

Vertical lifting clamps

Lateral lifting clamps

Horizontal lateral lifting clamps, lifting hooks

Steel beam lifting clamps, balance

» Suitable for Various Steel Structures

HHC

LIFTING HOOK

CHECK!



Operation manual & parts drawing

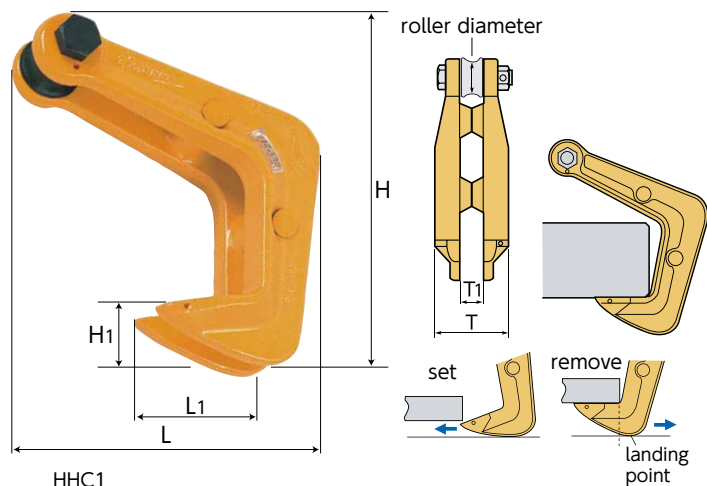

Example of use

⚠ For safety, always use lifting hooks at 4 or more points in opposite positions. For steel beams and pipes, lift at 2 points positioned at both ends. * Always hang the wire rope as shown in the drawing below.

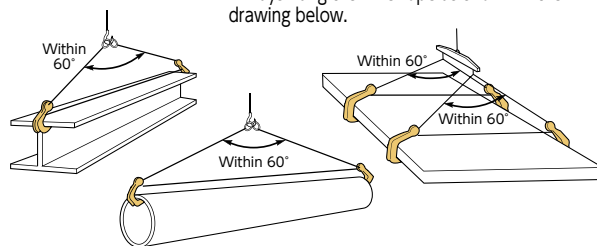

* Conduct daily inspection to confirm that all parts are functioning properly.

Features

- Ideal for lifting and handling various steel structures.
- The roller at the head of the hook prevents from damaging the wire rope.
- The sharp hook ends enable easy inserting into small clearance.
- The landing point designed slightly outside of the hook makes the remove operation very smooth.

Item No.	Rated capacity (ton)	Max. plate thickness	Size (mm)								N.W. (kg)
			L	L1	H	H1	T	T1	Roller dia.		
HHC0.5	0.5	58	121	42	152	27	63	30	19	1.1	
HHC1	1	65	144	47	178	33	80	40	23.5	2.1	
HHC2	2	80	182	58	223	42	105	54	30	4.5	
HHC3	3	95	215	68	264	49	125	65	35	7.8	
HHC5	5	125	279	90	342	60	160	85	44	16.5	

Screw cam clamps

Beam clamps

Super foot locks, lifting hooks

Super lock hooks

Drum lift clamps

Lifting hooks for forklift, rail clamps

Reinforcing rod vertical lifting clamps

safety belt clamps

* Parts drawings and operation manuals can be downloaded from our website.
● For all the appendix, please refer to P.54 ~56