

# REPLACEMENT PARTS AND ASSEMBLIES

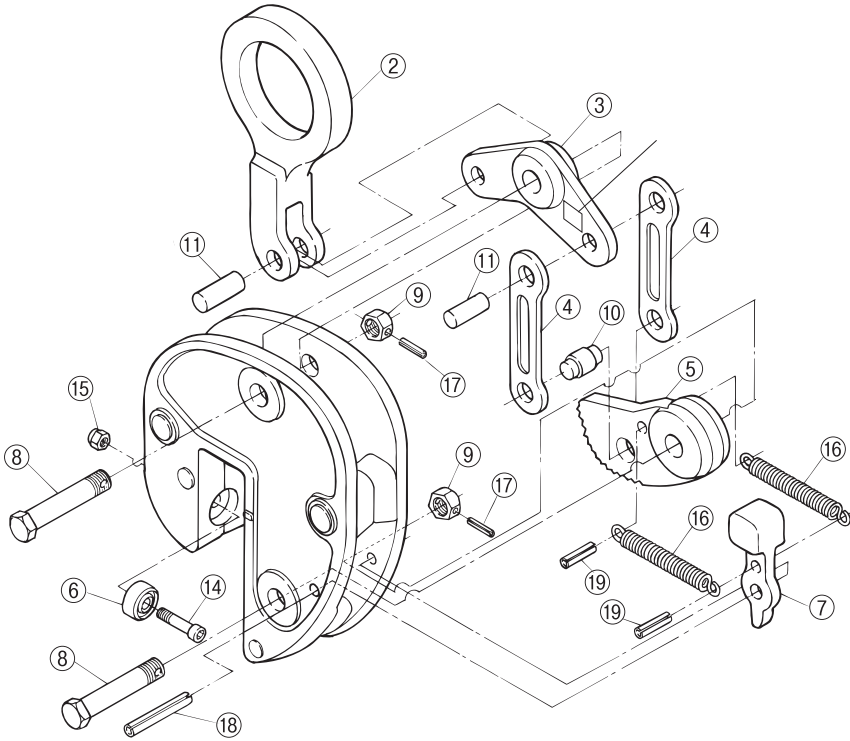

Part No.	Part Name	Item No.	Set Q'ty
<b>SHACKLE</b>		<b>SVH</b>	
2	Support pin for shackle	SVCH	1
11	Spherical Based Cam	SVCY	1
<b>LINK ASSEMBLY</b>		<b>SVL</b>	
3	L-shape link	SVCL	1
4	I-shape link	SVCI	2
11	Connection pin for link	SVCY	1
8	Support bolt	SVCX	1
9	Support nut		1
17	Spring for support pin	SVCD	1
<b>CAM ASSEMBLY</b>		<b>SVT</b>	
5	Cam	SVCT	1
19	Spring pin for spring	SVCQ	1
8	Support bolt	SVCX	1
9	Support nut		1
17	Spring for support pin	SVCD	1
10	Connection pin for cam	SVCK	1

Part No.	Part Name	Item No.	Set Q'ty
<b>PAD ASSEMBLY</b>		<b>SVP</b>	
6	Pad	SVCP	1
14	Hex. hole head bolt	SVCV	1
15	Nylon nut		1
<b>STOPPER ASSEMBLY</b>		<b>SVR</b>	
7	Stopper	SVCR	1
19	Spring pin for spring	SVCQ	1
18	Spring pin for stopper	SVCU	1
16	Spring for cam	SVCS	2

- 1) When ordering, specify the rated capacity (ton) of item No.  
(Example: Cam for SVC3 is SVT3)
- 2) Periodic lubrication is required at pin and working portion.