

HHC

Standard

ITEM No.	Capacity (tons)	Max.plate thickness(mm)	Weight (kg)
HHCO.5	0.5	58	1.1
HHC1	1	65	2.1
HHC2	2	80	4.5
HHC3	3	95	7.8
HHC5	5	125	16.5

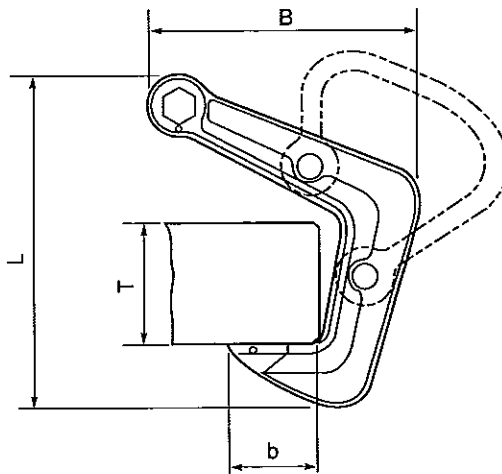
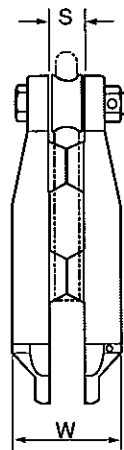

Principal dimensions of types HHC						(Unit : mm)
Capacity	T(Max.)	L	B	b	S	W
0.5ton	58	152	121	42	30	63
1 ton	65	178	144	47	40	80
2 ton	80	223	182	58	54	105
3 ton	95	264	215	68	65	125
5 ton	125	342	279	90	85	160

Replacement parts and fittings

(Model : HHC)

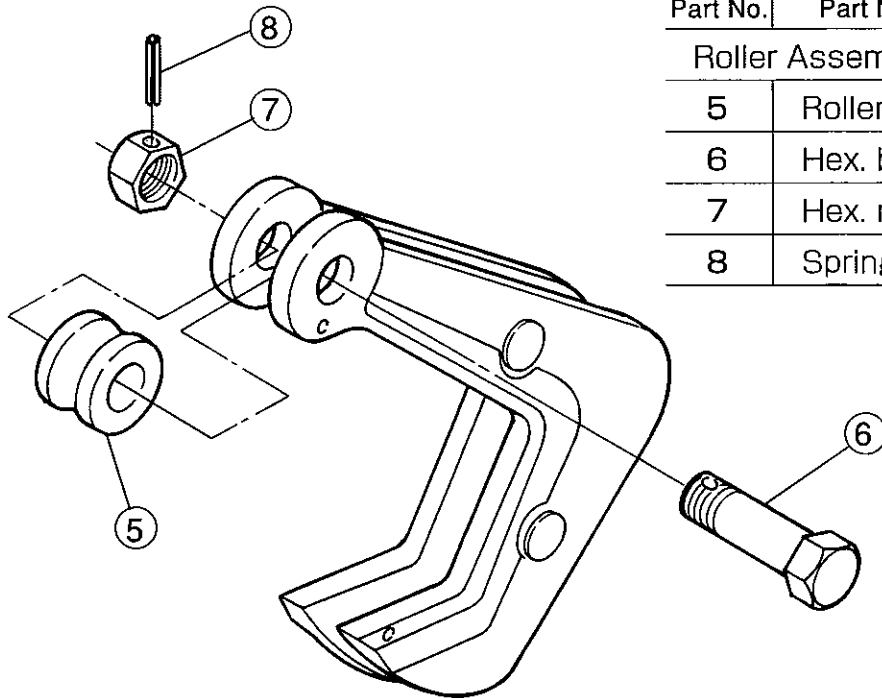

Part No.	Part Name	ITEM No.
Roller Assembling		HHR
5	Roller	HHCR
6	Hex. bolt	HHCK
7	Hex. nut	
8	Spring pin	HHCP

Standards for checking hook

(Model : HHC)

Check the operation of each part daily. Especially, measure the distance of safety checking points on the body periodically as to the limitation in the use of hook.

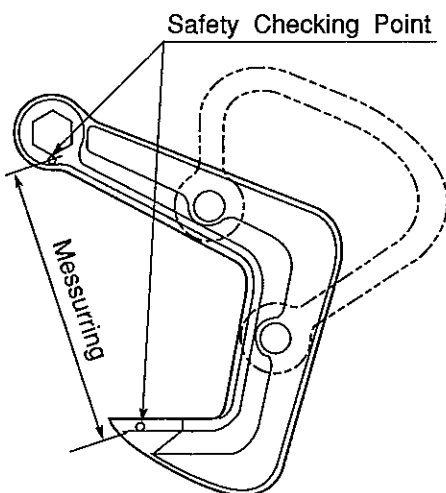

ITEM No.	Capacity (tons)	Distance of Safety Checking Point	
		Standard (mm)	Limit of use (mm)
HHC0.5	0.5	111	114.5
HHC 1	1	126	130.0
HHC 2	2	154	158.5
HHC 3	3	187	192.5
HHC 5	5	243	250.5