

# Mini Chain Block CB 250kg, 0.25t

- Rugged steel body construction yet lightweight and portable
- Double cover protection for brake chamber
- Drop forged & heat treated alloy hooks
- High quality alloy calibrated load chain
- Heat treated alloy steel triple spur gears and pinion shaft
- Operating temperature of -40°C to +50°C (-40°F to +122°F)
- Proof tested to 1.5 times rated capacity
- Meets or exceeds all international standards

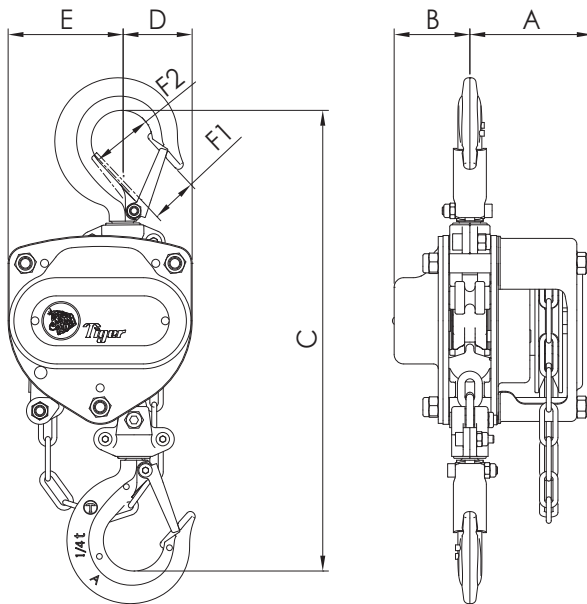

Product Code	Capacity (tons, T)	Effort (kg, lb)	Dimensions (mm, in)							Load Chain		Std. Lift (ft)	Unit weight w/ standard lift (lb)	Adder weight per additional ft of lift (lb)
			A	B	C	D	E	F1	F2	Diameter (mm)	No. of falls			
CB-0025	0.25, 0.275	17, 37	64, 2.52	40, 1.58	240, 9.45	36, 1.42	60, 2.37	22, 0.867	31, 1.22	Ø4.0	1	10	8.4	0.15