

Low Headroom Combination Chain Block & Trolley LHCG

- (LH) low headroom design
- Range from 1.0t to 10t
- Operating temperature of -30°C to +50°C (temperature range of -50°C to +50°C available as an option)
- Available with a chain container
- Available with overload protection
- Available with trolley beam locking device
- Spark Resistant version available

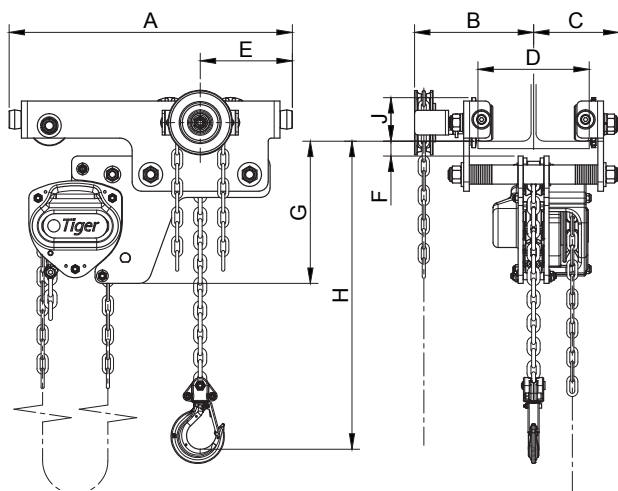

Above drawing is reference only

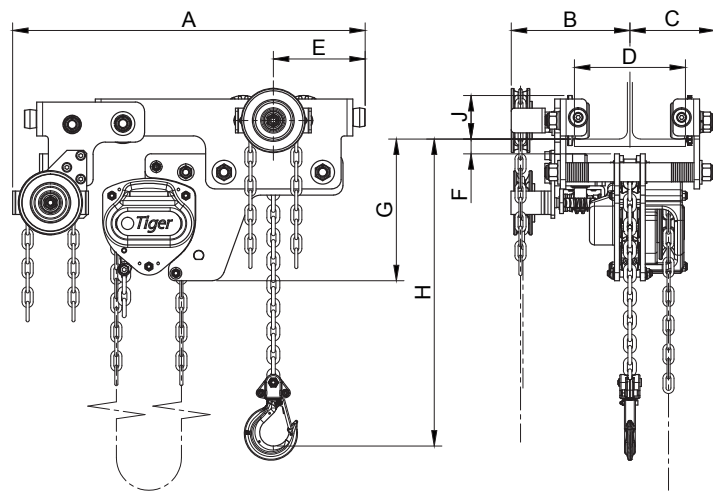

Above drawing is reference only

Product Code	Capacity (tons, T)	Dimensions (mm, in)									Unit weight w/ standard lift (lb)
		A	B	C	D	E	F	G	H	J	
LHCG-0100	1.0, 1.1	458, 18	192, 8	138, 5	62-180, 2-7	149, 6	24, 1	230, 9	210, 8	70.5, 3	74
LHCG-0200	2.0, 2.2	582, 23	196, 8	146, 6	88-180, 3-7	179, 7	24, 1	299, 12	260, 10	79.5, 3	111
LHCG-0300	3.0, 3.3	698, 27	196, 8	153, 6	88-180, 3-7	221, 9	32, 1	341, 13	305, 12	96.5, 4	174
LHCG-0600	6.0, 6.6	808, 32	209, 8	164, 6	106-194, 4-8	274, 11	32, 1	344, 13	425, 17	117, 5	238
LHCG-1000	10.0, 11.0	972, 38	336, 13	263, 10	150-320, 6-13	341, 13	45, 2	364, 14	550, 22	182, 7	587

Standard lift is 3m (10') and Standard geared trolley hand chain length is 2.4m (8'). Dimension D is the standard track width range. Please contact us for track widths outside of this range. Dimension F is the maximum beam flange thickness.