



CRT

Rail Clamp



ORIGINAL INSTRUCTION GUIDE

- PLEASE PASS ONTO OPERATOR

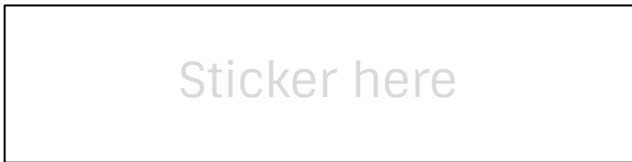



Operator Instruction Guide



MUST READ BEFORE USE

1. It is important that this manual is read and fully understood and that all instructions are followed before using the Tiger product.
2. Inspect the product for any damage or wear before use. Do not use the product if it is not in good working order.
3. The product must be operated, inspected, maintained and repaired by a competently trained person in accordance with applicable safety codes and regulations.
4. Do not use the machine to lift, support or transport people in any way.
5. Do not lift loads over or near people.
6. Never work under or near hoisted loads.
7. The product is for manual operation only. Do not attempt to use a motorized mechanical device to operate the product.
8. Do not use the product in explosive environments unless an ATEX version has been supplied.
9. It is the responsibility of the operator to exercise caution, use good practice, common sense and be familiar with proper rigging techniques.
10. Improper use could result in death or serious injury.
11. The supplier takes no responsibility for any form of consequential loss or damage as the result of unauthorised repair or use of spare part other than those issued on behalf of the manufacturer/supplier.

Contents:

1. Safety Information	1	6. Manufacturer Testing and Verification	4
2. Function/Operation	2	7. Product Warranty and Warnings	5
3. Inspection	3	8. Technical Data	6
4. Maintenance	4	9. Exploded Diagrams	6
5. Transport, Storage, Decommissioning and Disposal	4		

For details of the full Tiger product range visit our website: www.tigerlifting.com

Due to our policy of continual product development, dimensions, weights and specifications may change without prior notice.

© Copyright Tiger Lifting UK Limited. No part of this manual shall be reproduced, transmitted, transcribed, translated into any language human or electronic, stored in any electronic retrieval system, in any form without the written permission of Tiger Lifting UK Limited, Morpeth, UK

1. Safety Information

The operating company is responsible for the proper and professional instruction of the operating personnel. The personnel responsible for operation, maintenance or repair of the product must read, understand and follow these operating instructions. These instructions are intended to make the user familiar with the product and enable them to use it to the full extent of its intended capabilities.

The operating instructions must always be available at the place where the product is operated. Apart from the operating instructions and the accident prevention act valid for the respective country and area where the product is used, statutory regulations and procedures along with the commonly accepted regulations for safe and professional work must also be adhered to. The indicated protective measures will only provide the necessary safety if the product is operated correctly and installed and/or maintained according to the instructions. The operating company must be committed to ensure safe and trouble-free operation of the product.



Health and Safety at Work

All equipment must be maintained and tested to meet relevant statutory regulations. It is the responsibility of every company to ensure that their employees have been fully and properly trained in the safe operation of their equipment.

Equipment Labelling

The identification stamping details the product type, model, manufacturer, year of manufacture, working load limit (WLL), serial number and the jaw range. The CE marking indicates compliance with the essential health and safety requirements of the Machinery Directive 2006/42/EC. Other international standards that the unit conforms to may be shown.

Safety Instructions

! WARNING

- Always** store and handle clamps correctly.
- Always** inspect clamps before use and before placing into storage.
- Always** remove dirt, rust, paint, grease, oil and any other foreign matter from the surface of the steel plate before clamping.

- Never** use defective clamps.
- Never** return damaged clamps to storage.
- Never** lift track that is not fully engaged with the clamping jaws.
- Never** lift loads that are not balanced, and the holding action is not secure.
- Never** lift more than one track at a time.
- Never** leave load supported by the clamp unattended unless specific precautions have been taken.
- Never** expose clamps to chemicals, particularly acids, without consulting the supplier.
- Never** use the clamp in areas containing flammable vapours, liquids, gasses or combustible dust or fibres.
- Never** expose a clamp directly to the elements, water spray, steam etc without consulting the supplier.
- Never** use clamps which are unidentified or uncertified for lifting applications.
- Never** throw or drop clamps.
- Never** allow a load attached to the clamp to swing or spin unintentionally.
- Never** work under suspended loads.

2. Function/Operation

The Tiger CRT rail clamps are designed for lifting and pulling single rails lengthways and crossways, securely and safely. The clamps are designed to fit most types of rail section currently in use. The clamps are locked onto the rail-head via a lever operated spring mechanism.

Determine the weight of the rail being lifted and make sure that it does not exceed the rated load of the clamp. The track head thickness must be within the grip range of the clamp.

Our CRT clamps have a safety device with double function: For holding open and locking under load in order to hold rails securely, even when they are overturning, i.e. the grab cannot open accidentally.

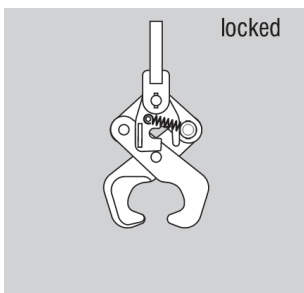

LOCKED: The spring tension that holds the safety latch, holds the lever against the lower bolt pin preventing the clamp from opening.

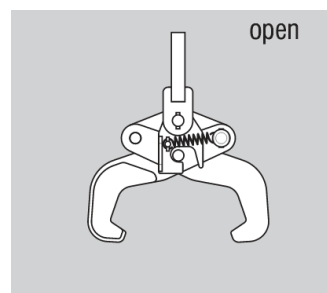

OPEN: The safety latch engages into the lower bolt pin, preventing the clamp from being unintentionally closed.



Attaching the clamp to the track

Lock the clamp into the open position then hold the clamp over the beam to be lifted, push the safety latch to the left to release it from the lower bolt pin to engage the jaws.

Releasing the clamp from the track

Lower the rail to the floor to release the weight from the clamp. Move the safety latch to the left to disengage the jaws, then lower the clamp until the clamp can be locked in the open position with the safety latch around the lower bolt pin. The clamp can now be released.

It is recommended to use clamps suspended from a lifting beam for long rail lengths.

The lifting capacity (e.g.:100%) corresponds to the lifting capacity of the grab. Pulling at an angle results in stronger forces especially in the lifting sling used.

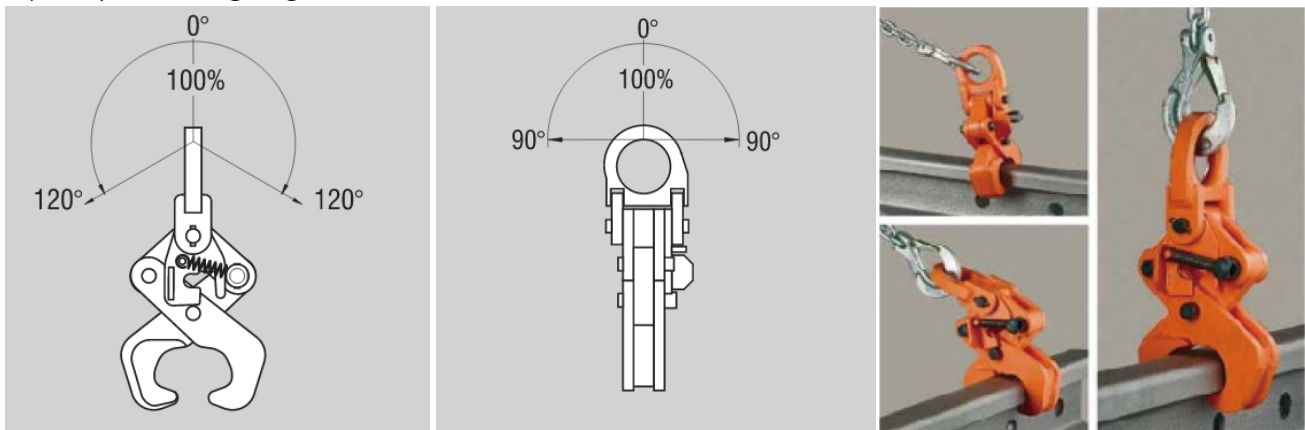

3. Inspection

According to national and international accident prevention and safety regulations, lifting equipment must be inspected:

- in accordance with the risk assessment of the operating company
- prior to initial operation
- before the unit is put into service for any subsequent use
- after substantial changes
- however, at least once every 6 months, by a competent person.

The intervals of inspection must be determined by the individual application and are based upon the type of service to which the clamp will be subjected. In the event of any defects refer the clamp to a Competent Person for thorough examination.

Examinations should include the following:

- Examine clamp for wear and distortion.
- Examine the clamping jaw and spring for damage.
- Examine the safety latches ability to engage and disengage the jaws.
- Examine for loose or missing fasteners, stops or nameplates.
- Examine for corrosion.
- Examine for illegible labels and markings.



4. Maintenance

The equipment should not be dismantled for cleaning or maintenance, except by an authorised competent person. Clean the clamp. Lubricate any moving parts. Correctly secure all fastenings.

5. Transport, Storage, Decommissioning and Disposal

Transporting the unit:

- Do not drop or throw the unit, always deposit it carefully.
- Use suitable transport means. These depend on the local conditions.

Storing or temporarily taking the unit out of service:

To ensure the continuing integrity of the unit you should store the unit in conditions that do not lead to damage or deterioration. Therefore:

- Inspect clamps and accessories before placing into storage.
- **Never** return damaged clamps to storage.
- The unit should be secured against unauthorised and unwarranted use.
- Store the unit in a clean and dry place.
- Wipe off all dirt and water.
- A light oil film should be applied to moving parts.
- Protect the unit including all accessories against contamination, humidity and damage by means of a suitable cover.
- Protect against corrosion.
- If the unit is to be used again after it has been taken out of service, it must first be inspected again by a competent person.

Disposal

When the product comes to the end of its lifecycle, after taking the unit out of service, recycle or dispose of the parts of the unit respecting local and national environmental regulations.

6. Manufacturer Testing and Verification

This product was manufactured under our single-unit control of quality and was passed with strict inspection in accordance with our inspection standards.

Capacity (tonne)	WLL (kg)	Test Load (kg)
2	2,000	4,000

Declaration of Conformity

Tiger CRT Clamps have a 4:1 factor of safety. They are tested in line with the requirements within applicable sections of ASME B30.20, the Australian Standard AS 4991 and EN13155:2003+A1:2009. All items comply with the essential health and safety requirements of the Machinery Directive 2006/42/EC.

Temperature range from -20°C to + 100°C (ambient and load temperatures).



7. Product Warranty and Warnings

Definitions

'Customer' means the individual, firm, company or other party with whom the Company contracts;

'Company' means Tiger Lifting UK Limited or Woo Sing Industrial Co., Ltd;

'Contract' the contract between the Company and the Customer for the sale and purchase of this product;

'Defective Goods' goods, parts or materials, which by reason of fault or incorrect design or workmanship, are found to be defective or fail or are unable to perform in accordance with a Contract;

One Year Limited Warranty

The Company makes every effort to assure that its products meet high quality and durability standards and extends the following warranty to the Customer of new products manufactured by the Company:

1. The Company warrants that this product, when shipped, shall be free from defects in materials and workmanship under normal use and service and the Company shall, at its election, repair or replace free of charge any Defective Goods, provided that all claims for defects under this warranty shall be made in writing immediately upon discovery and, in any event, within one (1) year from the date of purchase of this product by the Customer and provided, further, that Defective Goods shall be kept for examination by the Company or its authorised agents or returned to the Company or an authorised service centre upon request by the Company.
2. The Company does not warrant components of products provided by other manufacturers. However to the extent possible, the Company will assign to the "Purchaser" applicable warranties of such other manufacturers.
3. Except for the repair or replacement mentioned in (1.) above, which is the Company's sole liability and Customer's exclusive remedy under this warranty, the Company shall not be responsible for any other claims arising out of the purchase and use of this product, regardless of whether the Customer's claims are based on breach of contract, tort (including negligence), breach of statutory duty, or otherwise, including claims for any loss of profit, goodwill or business opportunity or any indirect or consequential loss arising under or in connection with the Contract.
4. This one year limited warranty is conditional upon the installation, maintenance and use of this product pursuant to the product manuals prepared in accordance with content instructions by the Company. The warranty on this product does not apply to defects due directly or indirectly to misuse, abuse, negligence or accidents. This warranty does not apply if the product has been subjected to improper fittings, alignment or maintenance.
5. The Company shall not be responsible for any loss or damage caused by transportation, prolonged or improper storage or normal wear and tear of this product or for loss of operating time.
6. This warranty shall not apply to this product if it has been fitted with or repaired with parts, components or items not supplied or approved by the Company or which have been modified or altered.
7. The Company limits all implied warranties to the period specified above from the date the product was purchased by the Customer.
8. Except as stated herein, any implied warranties or merchantability and fitness are excluded.

If our inspection discloses a defect, the Company will repair, replace the product or refund the purchase price, if we cannot readily or quickly provide a repair or replacement and if you are willing to accept such refund. The Company will return repaired or replacement products at The Company's expense, but if it is determined there is no defect, or that the defect resulted from causes not within the scope of Tiger Lifting's warranty, then the Customer must bear the cost of storing and retrieving the product.

! WARNING

The use of this product is beyond the control of Tiger Lifting. The warranty of this product is limited to the replacement cost of this product should it be found to be defective in material and/or workmanship. The warranty is void if the product is damaged, worn or used improperly. Normal wear and tear is not considered grounds for replacement. The Tiger Lifting product warranty does not apply where there has been excessive overloading of the product.

Disclaimer

We believe that the information in this document, including technical information and any advice, is reliable although we give no guarantee as to its accuracy or completeness. The user of our products must determine if the product, either used alone or conjunction with other products, is suitable for their purpose and assumes all risk and liability in connection with those decisions. We have made every effort to make sure this document is accurate. The information contained in this document does not form part of any contract.

Please also refer to our terms and conditions which can be found at: www.tigerlifting.com/terms-conditions/



8. Technical Data

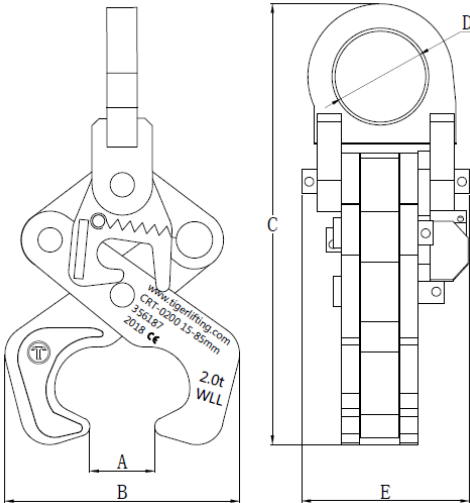

Product Code	Capacity (tonne)	Dimensions (mm)					Net Weight (kg)
		Jaw Opening A (mm)	B Max (mm)	C Max (mm)	D (mm)	E (mm)	
CRT-0200	2.0t	15-85	170	302	60	111	6.2

The load must weigh a minimum of 20% of the nominal carrying capacity of the clamp. This means that the minimum load that should be lifted with a 2 tonne lifting clamp is 400kg.

They are suitable for rail sizes S49, S54, S60s, UIC60.

Due to our policy of continual product development, dimensions, weights and specifications may change without prior notice.

9. Exploded Diagram

The following diagram is intended to clarify terms that appear in the Product Operation and the Inspection and Maintenance chapters.

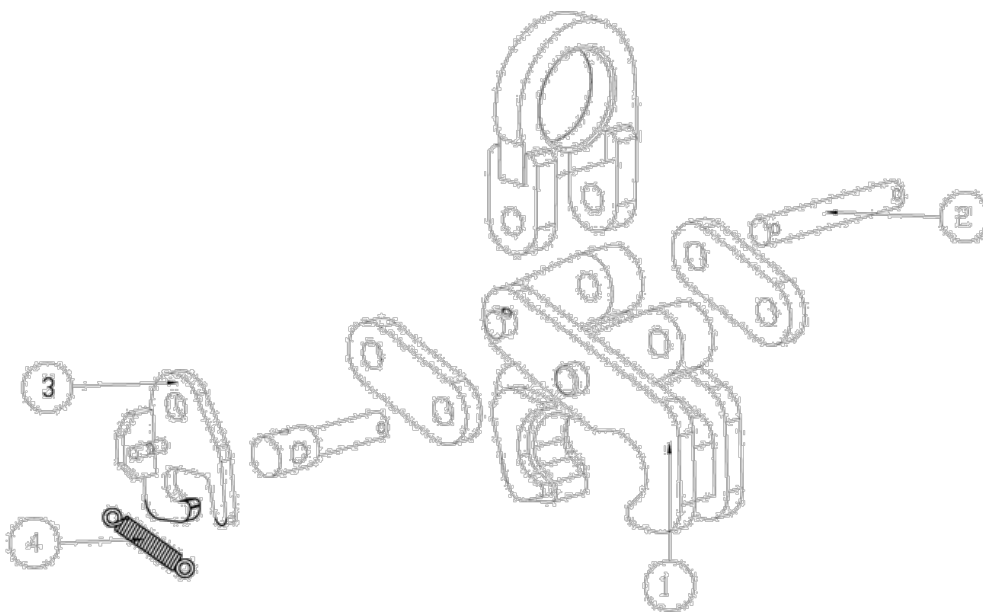

Part No.	Part Name
1	Body
2	Pins
3	Safety Lock
4	Spring



Tiger HQ Taiwan

Woo Sing Industrial Co., Ltd
6F, No. 118-1,
ZhongZheng Road
Shilin Dist.,
Taipei City
11145
Taiwan

☎ +886-2-2831 3035
📠 +886-2-2834 0188
✉ info@tigerlifting.com.tw

Tiger North America

Tiger Lifting NA
38381 N. Robert Wilson Rd.
Gonzales, Louisiana
70737
USA

☎ +1 225-647-1312
☎ +1 833-681-3057
✉ sales@tigerliftingna.com

www.tigerlifting.com



Tiger UK and Europe

Tiger Lifting UK Limited
Coquet Enterprise Park
Amble, Morpeth
Northumberland
NE65 0PE
UK

☎ +44 1665 605130
📠 +44 1665 603185
✉ info@tigerlifting.com

Representative in Europe

Tiger China – Sales Office

☎ +86 (0) 21 3133 2638
☎ +86 138 2377 3024
✉ info@tigerlifting.com.cn



© Copyright Tiger Lifting UK Limited. No part of this manual shall be reproduced, transmitted, transcribed, translated into any language human or electronic, stored in any electronic retrieval system, in any form without the written permission of Tiger Lifting UK Limited, Morpeth, UK

www.tigerlifting.com

