



# User Instruction Manual

## Dual Beam Trolley Anchor

Model # TYAA231

Model # TYAA232

Model # TYAA233

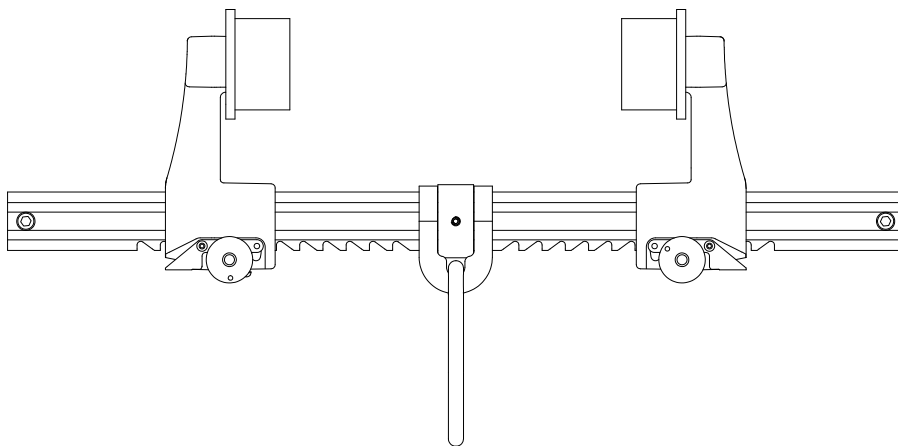

### MANUFACTURED BY:

Woo Sing Industrial Co., Ltd

No 20 Yunong Road

Shih-lin

Taipei

Taiwan

Phone: +886-2-2831 3035

Fax: +886-2-2834 0188

[info@tigerlifting.com.tw](mailto:info@tigerlifting.com.tw)

# Table of Contents

Warning and Important Notification.....	2
Dual Beam Trolley Anchor Components.....	2
Specifications.....	3
Applications.....	3
Installation and Use.....	5
Training.....	6
Inspection.....	6
Maintenance, Service, Storage.....	6
Inspection and Maintenance Log.....	7

## **WARNING:**

This product is to be used as part of a personal fall protection system. The user must read the manufacturer's instruction and be familiar with each component of the equipment. The user must fully understand this instruction and to be trained before using this equipment. This equipment should not be used for material lifting or any other use other than a fall protection system. This product is intended for one person using. Any alteration and misuse of this equipment, or failure to follow instructions, may result in serious injury or death.

## **IMPORTANT:**

If you have questions on the use, care, installation or suitability of this Dual Beam Trolley Anchor for your application, please contact your dealers, distributors, or manufacturer for a guide.

### **DUAL BEAM TROLLEY ANCHOR COMPONENTS**

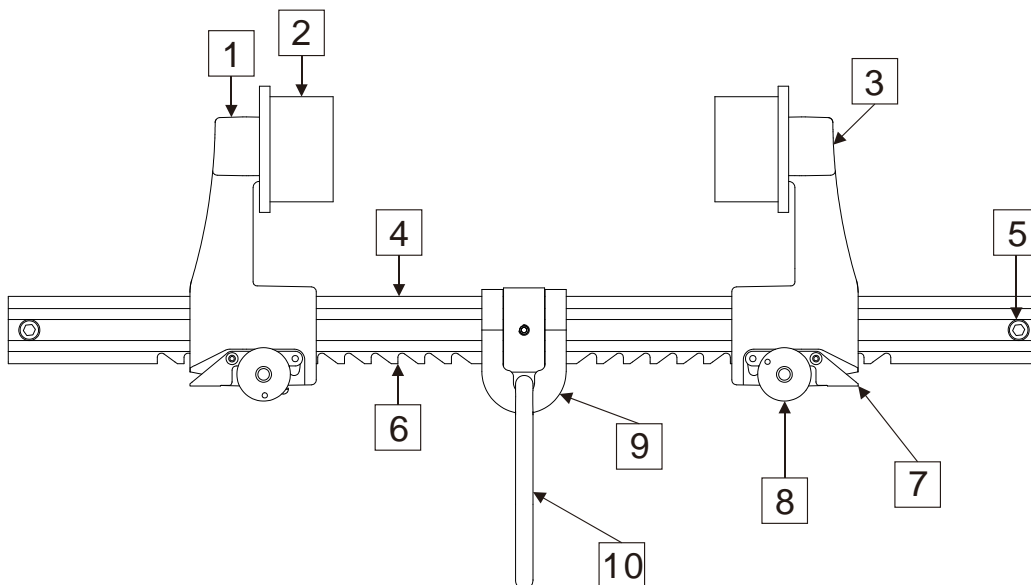

The Dual Beam Trolley Anchor consists of the following components:

1. Trolley Clamp
2. Trolley Wheel with Ball Bearing
3. Nylon Nut
4. Hexagonal Rod
5. End Screw w/Nylon Nut
6. Positioning ratchet for Lock Pin
7. Safety Lock
8. Quick Release Lock Pin
9. D-Ring Hanger
10. D-Ring

## SPECIFICATIONS

### Dimensions:

Beam Size Range,	Model TYAA231:	12-in. (305mm) Maximum 2.5-in. (63.5mm) Minimum
	Model TYAA232:	18-in. (457mm) Maximum 2.5-in. (63.5mm) Minimum
	Model TYAA233:	24-in. (610mm) Maximum 2.5-in. (63.5mm) Minimum
Flange Thickness,	Model TYAA231:	1.5-in.(38mm) Maximum
	Model TYAA232:	1.5-in. (38mm) Maximum
	Model TYAA233:	1.5-in. (38mm) Maximum

### Materials:

All materials used in the construction of this equipment are as follows:

- Stainless Steel
- Anodized Alloy Aluminium
- Plated Alloy Steel

### Weight:

Model TYAA231: 6.61 LB(3.00KG)

Model TYAA232: 7.23LB(3.28KG)

Model TYAA233: 7.85LB(3.56KG)

## APPLICATIONS

### Purpose:

The Dual Beam Trolley Anchor is used as an anchorage connector for a personal fall arrest system. It's designed to be attached on the Horizontal I-Beam. The Dual Beam Trolley Anchor might be used as an end termination for either a shock-absorbing lanyard or self-retracting lifeline for fall arrest, or with a positioning lanyard for fall restraint.

### Limitations:

- **Beam Flange Sizes:** The Dual Beam Trolley Anchor may only be installed on beams with flanges within the adjustment range of the model. See the **SPECIFICATION**.
- **Capacity:** This Dual Beam Trolley Anchor is designed for one person use with a combined weight (clothing, tools, etc.) of no more than 310 lbs (140kgs). No more than one personal protective system may be connected to this equipment at one time.

- **Free Fall:** Personal fall arrest systems used with this equipment must be rigged to limit the free fall to a maximum of 6 feet. The maximum free fall must always be within the manufacturer's free fall capacity of the system components used to arrest the fall. When a free fall greater than 6 feet and up to a maximum of 12 feet if possible, Tiger recommends using a personal fall arrest system incorporating with an energy absorbing lanyard.
- **Trolley Load Angle:** Loads imposed on the Dual Beam Trolley Anchor by the personal fall arrest system must remain within 30 degrees of the vertical centre line of the beam.

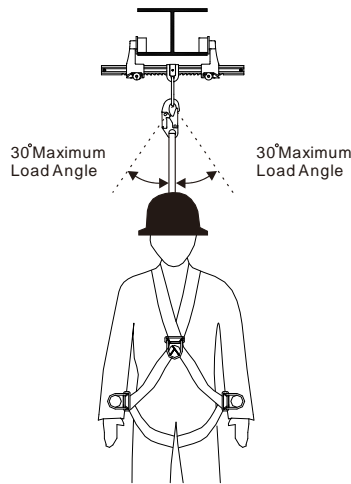

Trolley Load Angle

- **Swing Falls:** Before installing or using, make consideration for eliminating or minimizing all swing fall hazards. Swing falls occur when the anchor is not directly above the location where a fall occurs. The user must always work as close to be in line with the anchor point as possible. Swing falls significantly increase the possibility of serious injury or death in the event of a fall.

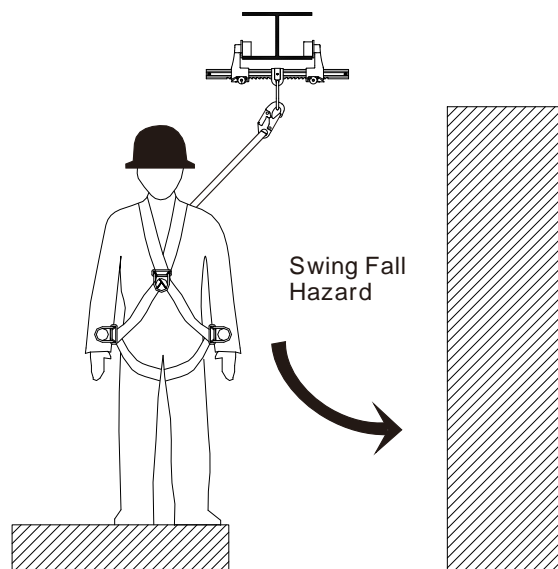

Swing Falls

- **Fall Clearance:** There must be sufficient clearance below the anchorage connector to arrest a fall before the user strikes the ground or other obstruction. The clearance required is dependent on the following safety factors:

- ◆ Elevation of Dual Beam Trolley Anchor
- ◆ Length of connecting subsystem
- ◆ Deceleration distance
- ◆ Movement of harness attachment element
- ◆ Worker height
- ◆ Free fall distance

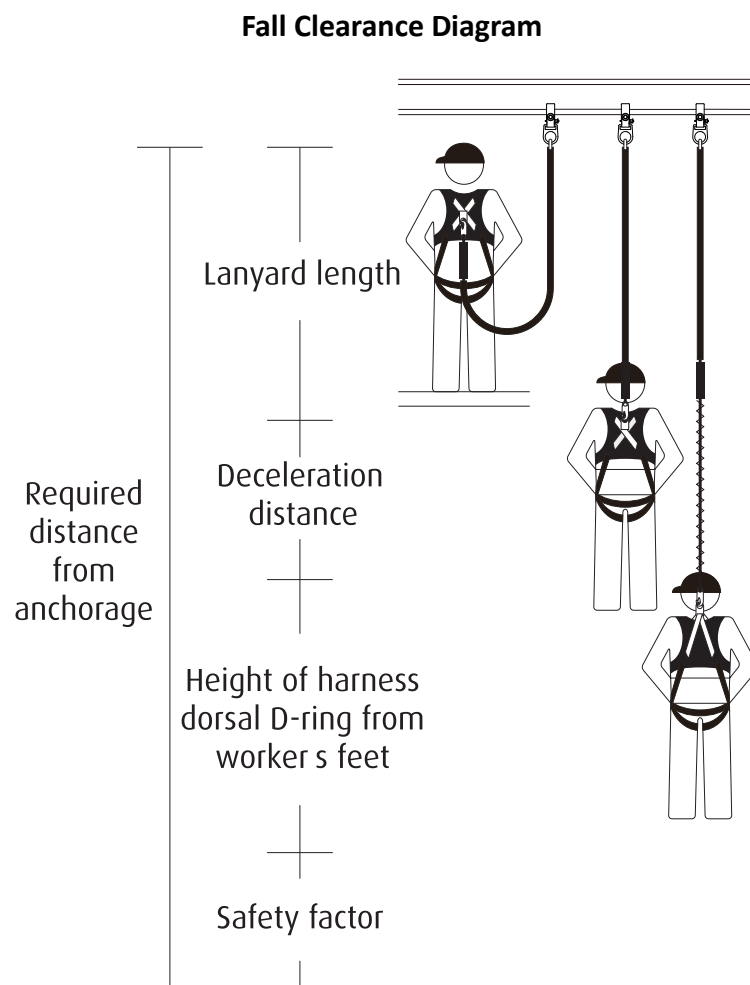

- **Personal Fall Arrest System:** The Dual Beam Trolley Anchor is designed for use with Tiger approved components or CE/ANSI certified components. Use of this equipment with non-approved components may result in incompatibility between equipment, and could affect the reliability and safety of the complete system. A full body harness must be worn by the user when connected to the Dual Beam Trolley Anchor. When making connections with the Dual Beam Trolley Anchor, eliminate all possibility of roll-out. Roll-out occurs when interference between a hook and the attachment point causes the hook gate to unintentionally open and release. All connector gates must be self-closing and self-locking.

## INSTALLATION AND USE

### Installation configuration:

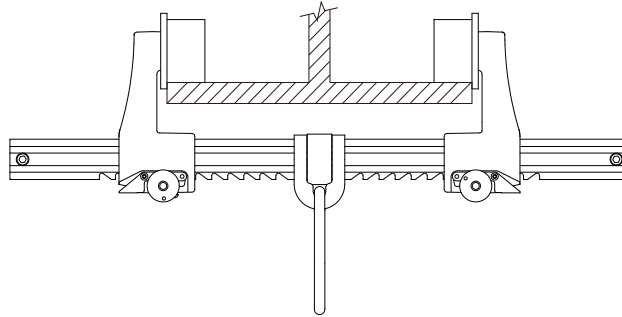

**Bottom Mount**

Inspect the equipment according to **INSPECTION** of this manual before each use.

The Dual Beam Trolley Anchor could only be installed on any I-beam for horizontal position, and located on the bottom of the I-beam.

Step 1. Remove the quick release lock pins. Then press the safety lock to adjust the trolley clamps.

Step 2. Place the Dual Beam Trolley Anchor onto beam flange on the bottom position of the I-beam.

Step 3. Place trolley clamp against one side of the beam flange. Slide the other trolley clamp against opposite side of the beam flange. Ensure the D-ring is at the middle position of the I-beam.

Step 4. Ensure the safety lock is in nearest position to the beam flange.

Step 5. Insert the quick release lock pins to fix the safety locks, ensuring pins are locked into place.

Step 6. Ensure the quick release lock pins have not bottomed out. If quick release pins have bottomed out, reinstall the trolley clamp to the next locking position. If the quick release lock pin is damaged or absent, the equipment is still in a workable condition. However for safety concerning, when one of the quick release lock pins is damaged or absent, the equipment must be sent back to your dealers, distributors, or manufacturer to replace a new quick release lock pin.

## TRAINING

It is the responsibility of the users to assure that they are familiar with the instructions, and are trained in the correct care and use of this equipment. Users must also be aware of the operating characteristics, application limits, and the consequences of improper use of this equipment.

## INSPECTION

### **Frequency:**

Before each use, inspect the Dual Beam Trolley Anchor according to following steps and see **DUAL BEAM TROLLEY ANCHOR COMPONENTS** for part identification. The Dual Beam Trolley Anchor must be formally inspected by a competent person other than the user at least annually. Record the results in **INSPECTION AND MAINTENANCE LOG**.

### **Inspection Steps:**

- Step 1. Inspect Dual Beam Trolley Anchor for damage: Look for cracks, dents, or deformities. Look for bending or wear on the hexagonal rod, trolley clamps, safety lock, quick release lock pin, and trolley wheels. Ensure no parts are missing.
- Step 2. Inspect entire unit for excessive corrosion.
- Step 3. Ensure the quick release lock pin can be inserted through the hole on safety lock button, and locks in place.
- Step 4. Record the inspection date and results in the **INSPECTION AND MAINTENANCE LOG**.

If inspection reveals an unsafe or defective condition, remove the equipment from service and destroy, or return to Tiger for repair.

**NOTE:** *Only Tiger or parties authorised in writing are qualified to repair this equipment.*

## MAINTENANCE, SERVICE, STORAGE

### **Cleaning:**

Periodically clean the Dual Beam Trolley Anchor by water and a mild soap solution. Do not use acids or other caustic chemicals that could damage the system components. A lubricant may be applied to the safety lock button and the quick release lock pin.

### **Storage:**

Store the equipment in a cool, dry, dark place, chemically neutral, away from sharp corners, sources of heat, humidity, corrosive substances or other damaging conditions.



## INSPECTION AND MAINTENANCE LOG

Company: \_\_\_\_\_ Location: \_\_\_\_\_ Date Purchased: \_\_\_\_\_

Serial Number: \_\_\_\_\_ Model Number: \_\_\_\_\_

Year	Date	By a Qualified Person	No Missing Parts	No Corrosion	No Deformation	Functioning Condition	No Changes to Attachment Structure
		Corrective Action			Maintenance Performed		
		Corrective Action			Maintenance Performed		
		Corrective Action			Maintenance Performed		
		Corrective Action			Maintenance Performed		
		Corrective Action			Maintenance Performed		
		Corrective Action			Maintenance Performed		
		Corrective Action			Maintenance Performed		
		Corrective Action			Maintenance Performed		