



TCB/SS12

Tiger Chain Block and
Tiger Corrosion Resistant
Chain Block

ORIGINAL INSTRUCTION GUIDE

- PLEASE PASS ONTO OPERATOR

Sticker here



Unit 1, Greensfield Industrial Estate,
Willowburn Avenue,
ALNWICK,
NE66 2DG
UK
+44 1665 605130

Woo Sing Industrial Co., Ltd
No 20 Yunong Road
Shih-lin
Taipei
Taiwan
+886-2-2831 3035

www.tigerlifting.com
Email: info@tigerlifting.com

Manual Tiger TCB-SS12 En 201605 v3.1





Operator Instruction Guide



MUST READ BEFORE USE

1. It is important that this manual is read and fully understood and that all instructions are followed before using the chain block.
2. Inspect the machine, chain and accessories for any damage or wear before use. Do not use the machine if it is not in good working order.
3. When a "DO NOT OPERATE" sign is placed on the hoist, do not operate the hoist until the sign has been removed by designated personnel.
4. The chain block must be operated, inspected, maintained and repaired by a competently trained person in accordance with applicable safety codes and regulations.
5. Do not use the machine to lift, support or transport people in any way.
6. Do not hoist loads over or near people.
7. Never work under or near hoisted loads.
8. The machine is for manual operation only. Do not attempt to use a motorized mechanical device to operate the machine.
9. Do not attempt to overload the machine as this could cause damage to person or machine.
10. Do not use the chain block in explosive environments unless an ATEX version has been supplied.
11. It is the responsibility of the operator to exercise caution, use good practice, common sense and be familiar with proper rigging techniques.
12. Improper chain block use could result in death or serious injury.
13. The supplier takes no responsibility for any form of consequential loss or damage as the result of unauthorised repair or use of spare part other than those issued on behalf of the manufacturer/supplier.
14. If an SS12 unit is to be used in multi-immersion applications then the separate instructions for multi-immersion use must also be followed.

Contents:

1. Safety Information	2	8. Transport, Storage, Decommissioning and Disposal	22
2. General Information	5	9. Manufacturer Testing and Verification	23
3. Function/Operation	7	10. Troubleshooting	24
4. Cross Hauling/Fleeting Operations	8	11. Product Warranty and Warnings	25
5. Inspection	9	12. Technical Data	26
6. Chain and Hooks	14	13. Exploded Diagrams	30
7. Maintenance	16	14. Inspection Log	38

For details of the full Tiger product range visit our website: www.tigerlifting.com

Due to our policy of continual product development, dimensions, weights and specifications may change without prior notice.

© Copyright Tiger Lifting UK Limited. No part of this manual shall be reproduced, transmitted, transcribed, translated into any language human or electronic, stored in any electronic retrieval system, in any form without the written permission of Tiger Lifting UK Limited, Alnwick, UK





1. Safety Information

Tiger Lifting products have been built in accordance with state of the art and generally accepted engineering standards. Nonetheless, incorrect handling when using the products may cause dangers to life and limb of the user or third parties and/or damage to the hoist or other property. The operating company is responsible for the proper and professional instruction of the operating personnel. The personnel responsible for operation, maintenance or repair of the product must read, understand and follow these operating instructions. These instructions are intended to make the user familiar with the product and enable them to use it to the full extent of its intended capabilities. This manual contains important Information to help you properly install, operate and maintain your chain block for maximum performance, economy and safety. Acting in accordance with these instructions helps to avoid danger, reduces repair costs and downtime and increases the reliability and lifetime of the product.

The operating instructions must always be available at the place where the product is operated. Apart from the operating instructions and the accident prevention act valid for the respective country and area where the product is used, statutory regulations and procedures along with the commonly accepted regulations for safe and professional work must also be adhered to. The indicated protective measures will only provide the necessary safety if the product is operated correctly and installed and/or maintained according to the instructions. The operating company must be committed to ensure safe and trouble-free operation of the product.

If the product's ability to do a job, or to do so safely is in question - DON'T TRY IT.

Definitions

! WARNING

Indicates a potentially hazardous situation that, if not avoided, could result in death or serious injury. It may also be used to alert against unsafe practices.

Competent Person

The competent person should have appropriate, practical and theoretical knowledge and experience of the Tiger product which will enable them to detect defects or weaknesses and to assess their importance in relation to the safety and continued use of the unit. Competent persons may be, for example, the maintenance engineers of the manufacturer or the supplier. However, the company may also assign performance of the inspection to its own appropriately trained specialist personnel.

Health and Safety at Work

All lifting equipment must be maintained and tested to meet relevant statutory regulations (e.g. PUWER/LOLER) when put to use. It is the responsibility of every company to ensure that their employees have been fully and properly trained in the safe operation of their equipment.

It is the owner's and user's responsibility to determine the suitability of a product for any particular use. It is recommended that all applicable industry, trade association, federal, state and local regulations are checked. Read all operating instructions and warnings before operation.

Equipment Labelling

The identification label/name plate details the product type, model, manufacturer, working load limit (WLL), serial number and the grade and size of the load chain. The CE marking indicates compliance with the essential health and safety requirements of the Machinery Directive 2006/42/EC. Other international standards that the unit conforms to may be shown. ATEX models will be marked with the  logo.



An example of the TCB14 label.
Labels on earlier models may be different.





Safety Instructions

! WARNING

Improper use of chain blocks could result in death or serious injury, to avoid these hazards:

- Always** be familiar with chain block operating controls, procedures and warnings.
- Always** allow only competently trained people to operate the hoist.
- Always** operate a hoist only if you are physically fit.
- Always** inspect the hoist before use (Refer to Chapter 5).
- Always** let the authorized personnel inspect the hoist periodically (Refer to Chapter 5).
- Always** make sure the chain block suspension hook is securely attached to a suitable support. The selection and calculation of the appropriate supporting structure are the responsibility of the operating company.
- Always** maintain a firm footing or be otherwise secured when operating the chain block.
- Always** make sure that load slings or other approved sling attachments are properly sized and seated in the hook saddle. Only approved and certified lifting tackle must be used.
- Always** make sure that the hook latch, is closed and not supporting any part of the load.
- Always** make sure that the load is free to move and will clear all obstructions.
- Always** take up slack chain carefully, check load balance, then lift a few centimetres and check to be sure the brake will hold the load and that attachments to the load are firmly seated.
- Always** avoid any swinging of the load or load hook.
- Always** protect load chain from weld spatter or other damaging contaminants.
- Always** report any malfunction, unusual performance or damage of lifting equipment to the appropriate person promptly.
- Always** inspect the chain block regularly, replace damaged or worn parts and keep appropriate records of maintenance.
- Always** use genuine Tiger parts when repairing the chain block.
- Always** apply lubricant to the load chain as recommended in this manual.
- Always** make sure that you and others are clear of the load before lifting begins and stay clear of the suspended load.
- Always** warn personnel of your intention to move a load in their area. The operator may start moving the load only after it has been attached correctly and all persons are clear of the danger zone.
- Always** make sure that the chain length is long enough for the intended job.
- Always** check that the hook latches are in proper working order before use (Refer to Chapter 6). Replace missing, damaged or broken hook latches.
- Always** be sure that the hoist's rated capacity, which is found on the hoist's name plate/label and forged into the hooks, is in excess of the weight of the load.
- Always** keep the load from hitting the chain.
- Always** use two hoists which have rated capacities equal to or more than the load to be lifted whenever you must use two hoists to lift a load. This will provide adequate protection in the event that a sudden load shift or failure of one hoist occurs.
- Always** check the brake before use (Refer to Chapter 5).
- Always** check for loose or missing parts before use.
- Always** lubricate the hoist regularly (Refer to Chapter 7).
- Always** pay attention to the load at all times when operating the hoist.
- Always** secure a hoist and loads properly after use.
- Always** consult the manufacturer or your dealer if you plan to use a hoist in a dusty, moist or greasy environment.
- Always** consult the manufacturer or your dealer if you plan to use a hoist in an excessively corrosive environment.
- Always** operate the hoist with manual power.
- Always** stop using the hoist immediately in case of functional defects or abnormal operating noise.
- Always** observe that the chain hangs straight (without twists) from chain block to lower hook.
- Always** lift in a straight line from hook to hook.
- Always** make sure the chain block is free to swivel on the upper hook.
- Always** fit load chains which have been approved by the manufacturer.





! WARNING

Improper use of chain blocks could result in death or serious injury, to avoid these hazards:

- Never** attempt to lift more than the rated load capacity (WLL) of the suspension and the supporting structure.
- Never** allow your attention to be diverted from operating the chain block.
- Never** attempt to operate this equipment under the influence of alcohol or drugs.
- Never** wrap the load chain around the load and hook onto itself as a sling/choker chain.
- Never** insert the point of the hook into a chain link.
- Never** lift a load if binding prevents equal loading on the load chain.
- Never** let the load swing or come into contact with other objects.
- Never** use the chain block to lift, lower, support or transport people.
- Never** lift a load over people.
- Never** work near or under hoisted loads.
- Never** use a damaged chain block or a chain block that is not working correctly.
- Never** use a chain block which has been taken out of service until it has been properly repaired or replaced.
- Never** use a hoist if the hook latch is missing or broken (if one is intended to be fitted).
- Never** splice load or hand chain by using pins, bolts, screw drivers or similar between links.
- Never** attempt to lengthen the load chain or repair damaged load chain.
- Never** force a hook or chain into place by hammering.
- Never** use the chain block with twisted, kinked, damaged, stretched or worn chain.
- Never** swing a suspended load.
- Never** support a load on the tip of the hook.
- Never** suspend a load for an extended period of time.
- Never** leave a suspended load unattended.
- Never** run the load chain over a sharp edge; use a sheave.
- Never** weld or cut a load suspended by a hoist.
- Never** use the hoist chain as a welding electrode or allow the chain or hook to be touched by a live welding electrode.
- Never** allow the chain or hook to be used as an earth for welding.
- Never** use the hoist with rusty chain.
- Never** run the lower hook block into the chain block frame or bring the load in contact with the chain block. Case and/or chain guide damage may result.
- Never** operate the chain block beyond limits of load chain travel or run the hook assembly into the frame of the block.
- Never** use the chain stop as an operational limit device.
- Never** operate a hoist if chain is jumping, if there is excessive noise, or if jamming, overloading or binding occurs.
- Never** use a hoist without both load chain anchoring points correctly fitted.
- Never** use a hoist without a name plate/label or with illegible name plate/label.
- Never** use modified or deformed hooks (refer to Chapter 6).
- Never** use a motor to operate a manual chain block.
- Never** use a hoist near fire or where hot objects may touch it.
- Never** use the hoist in temperatures below -40°C (-40°F) or above $+50^{\circ}\text{C}$ ($+122^{\circ}\text{F}$).
- Never** adjust or repair a chain block unless qualified to perform chain block maintenance.
- Never** perform maintenance on the hoist while it is supporting a load
- Never** use the unit for pulling free a jammed load
- Never** allow loads to drop when the chain is in a slack condition (danger of chain breakage and shock loading).
- Never** move the load into areas which are not visible to the operator.
- Never** suspend more than one load lifting attachment in the hook of the hoist.
- Never** reach into moving parts.
- Never** throw a hoist or allow the unit to fall from height. Always place it properly on the ground.
- Never** heat treat nor weld any part of the chain block, especially the load chain.





- Never** shock load chain block, chain or hook.
- Never** operate the chain block unless it is rigged to pull in a straight line from hook to hook.
- Never** lift a load unless the chain is properly seated in the chain wheel(s).
- Never** allow more than one operator to pull on a single hand chain at one time.
- Never** allow sharp contact between two chain blocks or between the chain block and any obstructions.
- Never** drag the chain, chain block or hook along the floor or across other objects.
- Never** use the hoist for any unauthorised purpose that is beyond the operation instructions contained in this manual.
- Never** use the chain hoist in acidic conditions.

2. General Information

The information in this manual is directed to the proper use, care and maintenance of the product and does not comprise a handbook on the broad subject of rigging. Rigging can be defined as the process of lifting and moving heavy loads using hoists and other mechanical equipment. Skill acquired through specialised experience and study is essential to safe rigging operations. Remember, proper rigging and lifting techniques are the responsibility of the operator.

Each Tiger chain block is built in accordance with the specifications contained herein and at the time of manufacture complies with our interpretation of applicable sections of the European standard BS EN 13157:2004+A1:2009, the Australian standard AS1418.2, the American standard ANSI/ASME B30.16, and the South African standard SANS 1594. Chain blocks supplied with slipping clutch overload protection are compliant with the Norwegian Standard NORSOK R-002. All items come with a test certificate or an EC Declaration of Conformity stating compliance with the essential health and safety requirements of the Machinery Directive 2006/42/EC. Tiger chain blocks are third party verified by SGS Certificate Number MDC 1302.

Unpacking

After opening the carton, the product should be carefully inspected for damage which may have occurred during shipment or handling. Check the chain block frame for dents or cracks and inspect the load chain for nicks and gouges. If shipping damage has occurred, contact your supplier.

! WARNING

Operating a unit with obvious external damage may cause the load to drop and that may result in personal injury and/or property damage. To avoid injury carefully check unit for external damage prior to installation.

Choose the Right Chain Block for the Job

The load capacity indicated on the unit is the maximum working load limit (WLL) that may be attached. Choose a chain block with the capacity for the job. Know the capacities of your loads, then match them. The application, environment it is to be used in, the size and type of load, the attachments to be used and the period of use must also be taken into consideration in selecting the right chain block for the job. Remember the chain block was designed to ease our burden, and carelessness not only endangers the operator, but in many cases, a valuable load.

Hoists are designed to provide a 4 to 1 safety factor. Supporting structures and load-attaching devices used in conjunction with this hoist must provide an adequate safety factor to handle the rated load, plus the weight of the hoist and attached equipment. This is the customer's responsibility. If in doubt, consult a registered structural engineer.



Inspecting

In addition to regular periodic maintenance inspections all chain blocks should be visually examined before being used. (Refer also to Chapter 5 – Inspection). The purpose of pre-use checks is to identify faulty equipment. Hoists are supplied fully lubricated from the factory. Lubrication of the load chain is recommended before initial hoist operation. See the section on Cross-Hauling (Chapter 4) for any usage of Tiger chain blocks that does not involve working in a direct line of pull.

After use

Service the hoist before storing it. See Chapter 8 for more information on storage.

- Clean the hoist thoroughly.
- Keep the hoist well-lubricated. Oil the load chain and hook shank.
- Store the hoist correctly against rain and moisture.

When the hoist is installed outdoors, exceptional care should be taken regarding maintenance. See Chapter 7 Maintenance for more information.

Key parts of a hand chain block

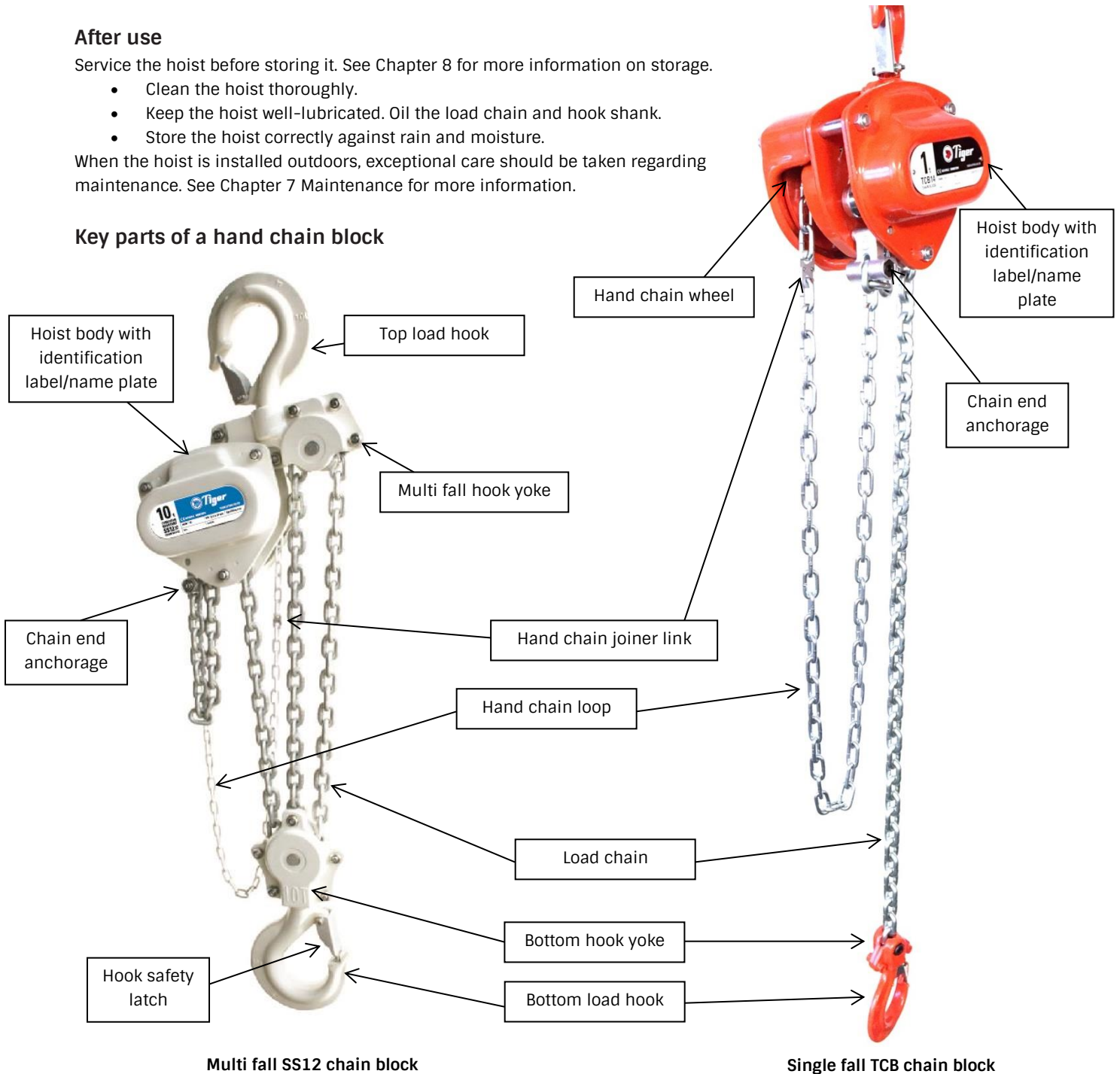



3. Function/Operation

! WARNING

If parts of the hoist are dropped, they can cause injury, death or property damage. Adequately support the hoist during installation.

Hand operated manual chain blocks are actuated by pulling on the hand chain that is fitted to a pocketed wheel that when rotated acts on the brake and either raises or lowers a load.

The hoist may be used at ambient temperatures between -40°C (-40°F) and $+50^{\circ}\text{C}$ ($+122^{\circ}\text{F}$). Consult the manufacturer in the case of extreme working conditions.

Note: Before use at ambient temperatures of less than 0°C , check the brake for freezing by lifting and lowering a small load 2 - 3 times. Before operating the hoist in special atmospheres (high humidity, salty, caustic, alkaline) or handling hazardous goods (e.g. molten compounds, radioactive materials), consult the manufacturer for advice.

Loads can be moved horizontally with the use of a trolley. Always transport the load in the horizontal direction slowly, carefully and close to the ground. Alternatively, refer to the section on cross hauling (Chapter 4)

Operation

Face the hand chain wheel side of the hoist.

Lifting the load

Pulling the hand chain in clockwise direction will raise the load.

Note: Depending on the type of load picked up, the lifting height may be reduced for units fitted with a chain container.

Lowering the load

Pulling the hand chain in anticlockwise direction will lower the load.

Note: The clicking sound of the pawl when a load is being raised indicates normal operation.

On TCB hoists with two chain block heads, use two operators, one on each of the two hand chains. To keep the load chain centred in the block assemblies, operate the units simultaneously and at the same speed. An equal amount of unloaded chain must be maintained under each hoist body.

! WARNING

Stop operating in the lifting direction when the hook block contacts the hoist body, as noted by the sudden increase in the hand chain pull or the tipping of the hook block.

The operator must ensure that the hoist is suspended in a manner that makes it possible to operate the unit without exposing himself or other personnel to danger by the unit itself, the suspension or the load.

Stand clear of all loads and avoid moving load over the heads of other personnel. Warn personnel of your intention to move a load in their area. When the unit is not in use, position the suspension (e.g. bottom block, load hook) above normal head height, if possible.

Do not allow load chain on hoists with two chain block heads to accumulate on one side (under one hoist body). Excessive loading to load chain anchor may occur resulting in a falling load which can cause death, injury or property damage.



Operating Principle of Overload Protected Chain Block

If the chain block is fitted with a slipping clutch overload mechanism then it is protected from overload.

The overload protection device is normally set to engage when a load of approximately 135% ($\pm 10\%$) of the WLL is lifted, unless otherwise specified during purchasing. When the load limit is exceeded, the clutch in the chain wheel will slip, allowing the hand wheel to be rotated whilst not engaging the gear box. This prevents further lifting of the load, though lowering is still possible. Continual overloading of the unit must be avoided as the efficiency of the clutch may be impaired. The overload clutch is factory set and should only be adjusted or repaired by a Tiger authorised repairer. If there is any doubt as to the unit's ability to lift a load then don't. Remove the unit from service and have it checked by your local Tiger distributor or service centre.

! WARNING

Never disassemble or attempt to adjust the overload limiter assembly. Any attempt to do so will void the warranty.

4. Cross Hauling/Fleeting Operations

The TCB and SS12 ranges of chain blocks fitted with the patented protected twin pawl quad cam brake system have undergone a full and comprehensive testing regime that was drawn up by industry specialists and Tiger's mechanical engineers to provide evidence that these units can be safely used for "fleeting" and "cross-hauling" applications up to 45°.

Note: All such operations should be carried out in accordance with manufacturer's instructions and fully risk assessed by a competent person.

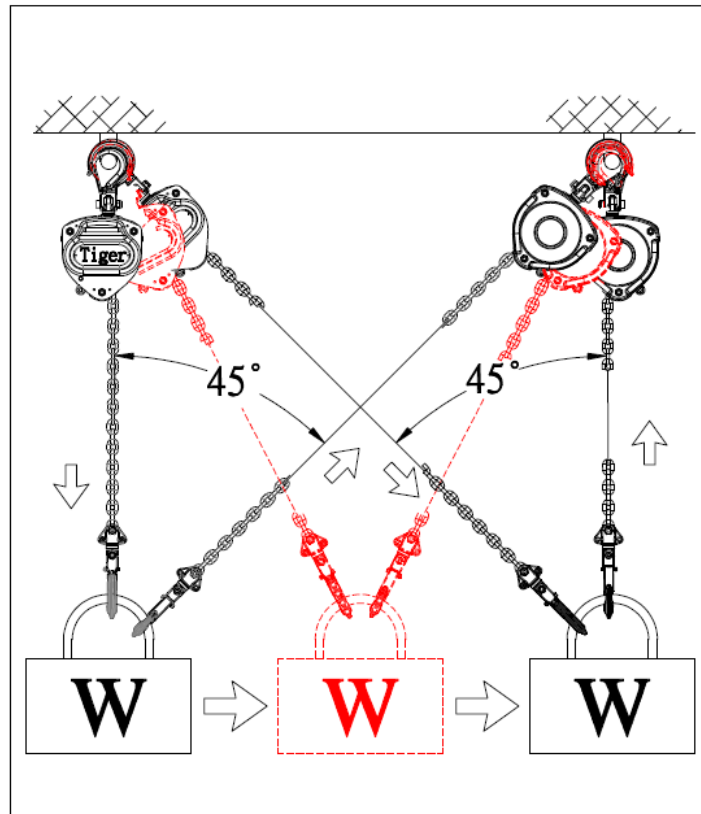



As well as following any industry or country specific guidance on chain blocks used at an angle to the vertical, we recommend that before commencing an operation using multiple hoists or involving the transfer of a load from one hoist to another, the following is adhered to:

- All the units that are to be used in such an operation must be of the same make and model and have the same rated capacity.
- Attachment points are critical and the suspension point must have a rated capacity equal to or greater than that of the load to be lifted at the angle that the load will be carried through.
- The attachment points must be designed and certified to work at angles away from the vertical.
- The attachment points must be the correct size to allow the hooks to attach correctly in the bowl of the hook and have enough clearance to allow the hook room to articulate.
- All fleeting operations should be risk assessed by a competent person.
- Load calculations and method statements should be produced.
- Proximity hazards should be accounted for.
- The load chain should be kept free of any twists and must enter the hoist body in a straight line over the load sheave.
- Care should be taken on multi fall hoists to ensure the bottom hook is not capsized/rolled over (i.e. bottom hook has looped through the multi fall chain) which results in the chain becoming twisted.
- When taking up the load or beginning the transfer between hoists particular care should be taken to align the block body so the hand chain is hanging vertically from the block and that the hoist body, load chain and top and bottom hooks are all in line.
- The top and bottom hooks should be free to rotate within the hook yoke and cannot become trapped or jammed causing stress areas in both the hook and the body.

5. Inspection

According to national and international accident prevention and safety regulations (for example LOLER for the UK), hoisting equipment must be inspected:

- in accordance with the risk assessment of the operating company
- prior to initial operation
- before the unit is put into service for any subsequent use
- after substantial changes
- however, at least once per year, by a competent person.

Note: Actual operating conditions (e.g. operation in galvanizing facilities) can dictate shorter inspection intervals.

The intervals of inspection must be determined by the individual application and are based upon the type of service to which the chain block will be subjected.

Prior to initial operation, before it is put into operation again and after substantial changes

Before the unit is put into operation, for the first time, for a subsequent use or after substantial repair or modification, unless you have received physical evidence that a thorough examination has been carried out which shows that the chain block is safe to use, it should be thoroughly examined by a competent person in compliance with applicable statutory regulations.

Typical pre-use inspection will consist of a visual inspection and a function check. These inspections are intended to establish that the hoist is in a safe condition, has been set up appropriately and is ready for operation, and that any defects or damage are detected and eliminated.

Inspect the chain block for operation warning notices and legibility. Deficiencies should be noted and brought to the attention of supervisors. Be sure defective chain blocks are tagged and taken out of service until repairs are made. Under no circumstances should you operate a malfunctioning chain block.



The following checks should be carried out before starting work:

Check the unit

- Inspect the unit for visual defects, e.g. deformations, damage, cracks, wear and corrosion marks.
- Check that the name plate/label showing the hoist capacity is attached and clearly legible.
- Check lubrication and lubricate if necessary.
- Check the functioning of the chain drive in unloaded condition. When facing the hand chain side of the hoist with no load, the brake is operating normally if the pawl "clicks" when the hand chain is wound in a clockwise direction and does not "click" when operated in the anti-clockwise direction.
- Check for loose or missing nuts and for missing split pins.

Check the brake function

Before starting work, always check operation of the brake. To do this, lift, pull or tension, then lower or release a load over a short distance with the unit. When the hand chain is released, the load must be held in any position. This check is intended to ensure that even at temperatures below 0 °C, the brake discs are not frozen. Repeat this at least twice before starting further work. Stop the load at various positions to test holding power and observe the amount of drift, if any.

To adjust the brake: (See Figure 1)

- A. Fully-tightened the check nut (C-31).
- B. Slacken off slightly from Position A, and insert the cotter/split pin (C-32) in the check nut.

Note: Replace the brake disc if thickness is less than 1.5mm (0.06 inch). If the brake discs are bonded with the ratchet gear, the entire bonded unit will need to be replaced.

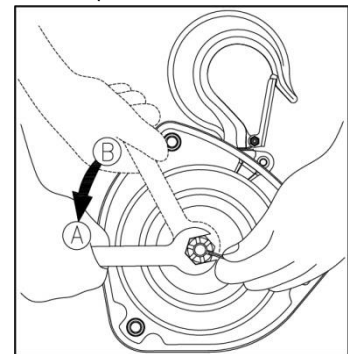

Figure 1

! WARNING

If the brake does not function properly, the unit must be immediately removed from service and placed in a quarantine area until it can be repaired by a relevant competent person.

Inspect the supporting structure and attachment point

Inspect the supporting structure for visual defects, e.g. deformations, damage, cracks, wear and corrosion marks. The attachment point for the hoist must be selected so that the supporting structure to which it is to be fitted has sufficient stability and to ensure that the expected forces can be safely absorbed. The unit must align freely also under load in order to avoid impermissible additional loading. Check that the hoist and the load are correctly attached. The selection and calculation of the appropriate supporting structure are the responsibility of the operating company.

Inspect the hand chain

If the unit's hand chain has been supplied with a Tiger Hand Chain Joiner link, make sure that it has been fitted correctly and is in good working order. See Chapter 6 Chain and Hooks for more information.

Inspect the load chain

Inspect the load chain for sufficient lubrication, mechanical damage and check for external defects, deformations, superficial cracks, wear, excessive rust and corrosion marks. Check for gouged, twisted and distorted links, and for deposits of foreign material which may be carried into the chain block mechanism. Do not operate chain blocks with twisted, kinked or damaged chain links. See Chapter 6 Chain and Hooks.



Inspection of the Load Chain Anchoring

The load chain anchoring must always be fitted securely at both ends. There must be no wear or incorrect alignment.

Inspection of the top hook and bottom load hook

The top and load hooks must be checked for cracks, deformations, damage, wear and corrosion marks. The safety latch must be attached, move freely and be fully functioning. Hooks that are bent, worn or have openings which are enlarged beyond normal throat opening (Chapter 12 Technical Data/Hooks) should not be used. If the latch does not engage in the throat opening of the hook, the chain block should be taken out of service. Hooks that do not fulfil all requirements must be replaced immediately. See Chapter 6 Chain and Hooks and Chapter 12 Technical Data/Hooks for more information. Welding on hooks, e.g. to compensate for wear or damage is not permissible.

Inspection of chain reeving in the bottom block

All units with two or more chain falls must be inspected before initial operation to ensure that the load chain is not twisted or kinked. The chains of hoists with two or more falls may become twisted if the bottom block is rolled over "capsized" (i.e. bottom hook has looped through the multi fall chain). A twist in the load chain can damage the chain block and cause injury.

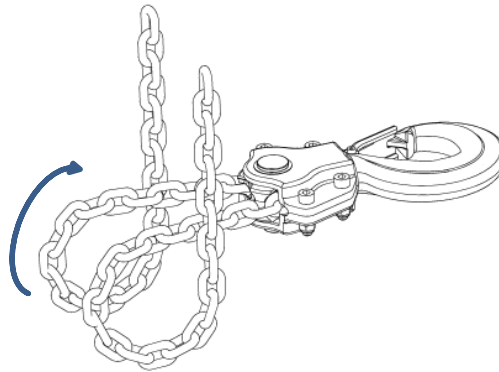

And finally, listen (while hoist operates) for unusual sounds which may indicate trouble.

Thorough Examination

Thorough Examination may be needed at several points during the life of the unit: on initial use or following installation, periodically during its life, or following exceptional circumstances. This chain block must be subject to periodic thorough examination in compliance with national statutory regulations. The intervals between periodic thorough examinations must consider the following:

- The condition of the unit.
- The environment in which it is to be used.
- The number of lifting operations and loads lifted.

Reports of thorough examination can be based on statutory maximum intervals or via a written examination scheme based on risks and hazards associated with use. i.e.:

- Annual Inspection.
- Period defined by examination scheme.
- Following exceptional circumstance.

Due to the construction of the chain block, it will be necessary to partially disassemble the unit to perform the periodic inspections.

Figures in the table in brackets refer to spare parts – see Chapter 13 for exploded diagrams of the various capacity chain blocks.



Item	Inspection method	Discard Limit/Criteria	Measures
Name plate (C-01)	Check visually	Attached and hoist capacity clearly legible	Reattach or replace the name plate/label (C-01)
Hook opening	Measure hook opening	See Chapter 6 – hook measurement	Replace the hook (C-12, C-15)
Hook deformation	Check visually	Twist not large enough to detect visually	Replace the hook (C-12, C-15)
Hook wear	Measure hook	See Chapter 6 and Chapter 12 for hook measurements	Replace the hook (C-12, C-15)
Hook flaws	Check visually	No great damage permitted	Replace the hook (C-12, C-15)
Hook movement	Turn hook	Turns smoothly	Replace the hook (C-12, C-15)
Hook fixtures including top and bottom hook pins	Check visually	No slack, missing or deformed fittings. Suspension pin not bent, cracked or worn	Replace the hook (C-12, C-15) or relevant fittings (C-12-I, C-15-I)
Hook latch (C-00)	Check visually	Attached, moving freely and fully functioning	Replace the latch (C-00) or hook (C-12, C-15)
Hook yoke mounting hole	Measure the hole-diameter of the joint area in two directions at right angles.	Deformation is not permitted. If each measurement differs by more than 0.5mm it is not a circle	Replace the hook (C-12, C-15)
Idle load sheave rotation	Hold the load chain with both hands and turn the idle sheave by moving the chain up and down.	Smooth rotation	Overhaul
Load chain wear	Measure pitch	See Chapter 6 – Chain Maximum Allowable Gauge Length	Replace the chain
Load chain rust, flaws, deformation	Check visually	No obvious rust (apply oil as necessary) No twists or harmful flaws	Remove the rust Replace the chain
Lifting and Lowering	Lift and lower a light load	No abnormal difficulty in lifting or lowering, hoist operates smoothly and pawl clicks during lifting None of the following occur: • Lifting impossible • Load falls if hand chain released • Load falls while lowering • Load slips	Overhaul and service. Overhaul and service.
Brake mechanism – flaws on brake surface (C-22, C-23)	Check visually	No flaws due to scratching or gouging by foreign matter Not worn, glazed or contaminated No discoloration caused by overheating	Replace the part Replace the part Replace the part
Brake mechanism – flaws on disc hub (C-21)	Check visually	No flaws due to scratching or gouging by foreign matter	Replace the part
Brake mechanism – wear on brake disc (C-22)	Measure thickness	Uniform thickness and thickness is greater than or equal to 1.5mm (0.06 inch)	Replace the part
Brake mechanism – flatness of brake disc (C-22)	Check clearance with straight gauge	Clearance uniform. Internal part not thicker than external edge	Replace the part
Brake mechanism – surface on brake disc (C-22)	Check	Friction disks must always be kept free from grease, oil, water or dirt. Bonding of the friction disks must be secure	Replace the part



Item	Inspection method	Discard Limit/Criteria	Measures
Brake mechanism - wear and rust on ratchet gear (C-23)	Check visually	Teeth wear not excessive, pawls still fully engage No rust or corrosion	Replace the part
Load sheave wear and deformation (C-14)	Check visually	No excess wear or no deformation or no burr due to load chain contact is permitted on the surface of load chain pocket	Replace the part
Load chain guide (C-13)	Check	Rotate freely and retain chain in the pockets of the load sheave. No excessive wear	Replace the part
Pinion gears wear and flaw (C-05)	Check visually	Teeth free from excessive wear or flaws	Replace the part
Hand wheel wear and deformation (C-28)	Check visually	No excess wear or deformation on surface of hand chain pockets Turn hand wheel and check if it touches the cover No scoring of hand wheel hub	Replace the part Replace the part Replace the part
Side plate hole for top hook pin deformation	Check visually	Holes in gear side plate and wheel side plate for top hook pin not oval	Replace the wheel side plate (C-20) gear side plate (C-09) or top hook pin (C-15-I) as appropriate
Side plate stay bolts restraint slack	Tap	No slack allowed	Replace the part (C-20)
Deformation of chain stripper (C-10)	Check visually	No excess crush or damage on stripper tip allowed	Replace the part
Flaw on load chain guide (C-13)	Check visually	Turns lightly, no significant deformation	Replace the part
Load chain anchoring not attached to load (C-11)	Check visually	correctly fitted at the "no load" end of the chain	Fix load chain to end anchorage correctly
Load chain anchoring slack (C-11)	Check visually	Holes in gear side plate and wheel side plate for load chain anchor not oval	Replace the wheel side plate (C-20) gear side plate (C-09) or load chain anchoring (C-11) as appropriate
Load chain anchoring deformation (C-11)	Check visually	Chain end anchoring articulating normally and not deformed	Replace the part (C-11)
Pawl wear (C-25)	Check visually	Tip of the pawls not worn	Replace the part
Pawl movement (C-25)	Check	Pawls move freely on the pawl pins (apply a thin coat of lubricant to the pawl pin before reassembling the unit)	Lubricate or overhaul
Pawl Spring missing, corroded, stretched or broken (C-24)	Check visually	Spring is in place and not stretched, corroded or broken	Replace the part
Loose or missing bolts, nuts, pins or rivets.	Check	All bolts, nuts, pins or rivets are securely fitted	Tighten or replace as necessary

Initial inspection and recurring inspections must be documented. Chapter 14 contains the inspection log which must be maintained for each block. Any deficiencies noted are to be corrected before the chain block is returned to service.

The external conditions may show the need for a detailed inspection which, in turn, may require the use of non-destructive type testing. Any parts that are deemed unserviceable are to be replaced with new parts before the unit is returned to service. It is very important that the unserviceable parts are destroyed to prevent possible future use as a repair item and are properly disposed of.

Note: Only qualified personnel to perform chain block maintenance.





6. Chain and Hooks

The hooks and load chains are made of special alloy-steels and are precisely heat-treated. Never weld or heat-treat them again.

Load Chain

The load chains are exceptionally long-wearing, but wear is unavoidable and certain conditions will cause wear and corrosion that will lessen the strength. Inspect the load chain for sufficient lubrication, mechanical damage and check for external defects, deformations, superficial cracks, wear and corrosion marks.

Round steel section chains must be replaced when the original nominal thickness 'd' on the chain link with the worst wear has been reduced by more than 10% or when the chain has elongated to a value greater than the discard levels shown in the tables below. There are two alternative tables for either measuring the chain over 21 links or measuring the chain over 7 pitches. Chain should be clean, free of twists and pulled taut before measuring.

Measuring the diameter of the chain

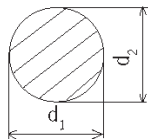

$$d_m = \frac{d_1 + d_2}{2}$$

Replace the chain if $d_m \leq 0.9 \times d$, where d is the normal diameter of the chain wire.

Measuring over 21 links

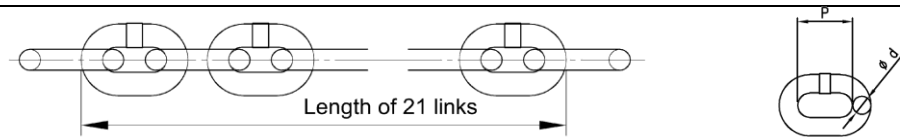

Capacity (tonnes)	Diameter of Chain Wire dØ (mm)	Discard if Diameter of Chain Wire dØ (mm) ≤	Dimensions of Chain (mm) (dØ x P)	Discard if 21 links (mm) ≥
0.5/1.0	6.3	5.7	6.3 × 19	421.6
1.5/2.0t lite/3.0t twin	7.1	6.4	7.1 × 21	467.4
2.0/5.0/8.0	8.0	7.2	8 × 24	533.4
3.0 Single/10.0/15.0/20.0/30.0	10.0	9.0	10 × 30	668.0

Measuring over 7 pitches

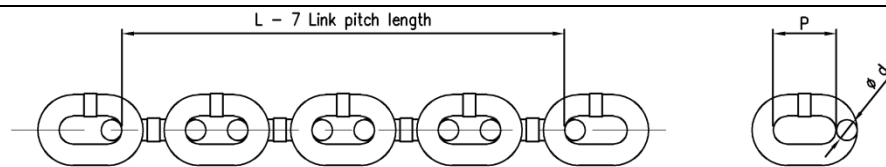

Capacity (tonnes)	Diameter of Chain Wire dØ (mm)	Discard if Diameter of Chain Wire dØ (mm) ≤	Dimensions of Chain (mm) (dØ x P)	Discard if L (mm) ≥
0.5/1.0	6.3	5.7	6.3 × 19	137.0
1.5/2.0t lite/3.0t twin	7.1	6.4	7.1 × 21	151.5
2.0/5.0/8.0	8.0	7.2	8 × 24	173.5
3.0 Single/10.0/15.0/20.0/30.0	10.0	9.0	10 × 30	216.5





Do not knot the load chain or splice/connect it by using pins, bolts, screw drivers or similar. Do not repair load chains installed in the hoist. Protect load chain from weld spatter or other damaging contaminants.

Only fit load chains which have been approved by the manufacturer. Non-compliance with this specification will render the legal warranty or guarantee void with immediate effect. See the Chapter 7 Maintenance for more information on maintenance of the load chain.

Hand chain

Tiger hand chain is 5mm × 24mm and either galvanised hand chain (generally for TCB blocks) or corrosion protected hand chain (generally for SS12 blocks).

Only fit hand chains which have been approved by the manufacturer. Non-compliance with this specification will render the legal warranty or guarantee void with immediate effect. See Chapter 7 Maintenance for more information on maintenance of the hand chain.

If the unit's hand chain has been supplied or subsequently fitted with a Tiger hand chain joiner link (HC-050-JL) make sure that it has been fitted correctly and is in good working order.

Make sure that the HC-050-JL has been fitted in the correct orientation as shown in figure 1 below. To achieve this, the HC-050-JL stainless steel rivet heads must be facing the front of the chain block and the joiner link must sit vertically within the hand wheel pocket as seen in figure 2 below:



Figure 1



Figure 2

Regularly inspect the HC-050-JL. In the event of any defects remove from service and refer the hoist to a competent person for thorough examination:

- Wear: make sure that the two stainless steel rivet heads are complete and have not been worn away or corroded, ensure the rivets are secure and tight and have a solid hold of both plates.
- Damage: ensure the link has not been damaged and that both sides of the link join together to form a flat surface without any signs of distortion by being: bent, twisted, cracked, corroded or stretched.

If the rivets are to be replaced during inspection or maintenance, the dimensions are 2.4mm × 6.0mm and must conform to EN ISO 15983 and the material is stainless steel. These and the joiner links are available as a spare part from Tiger.

Hooks

Do not remove the safety latches from top and/or bottom load hooks unless you are replacing them with new latches.

Never mark or hard stamp hooks or any other load bearing parts.



The hook opening will elongate with overloads and incorrect hooking. When the hook measurements have changed beyond the permissible discard limits shown in the table in Chapter 12 Technical Data/Hooks, it is dangerously deformed and must be replaced immediately.

Dye penetrant, magnetic particle inspections (MPI) or other suitable crack detecting inspections should be performed on hooks at least once a year, if external conditions indicate there has been unusual usage.

Newer models of the TCB are fitted with the patent pending Tiger “EZ check” 3 point marking system. With this system a quick check that the A and B measurements are the same (as shown in the diagram below) will indicate if the hooks have stretched. If $A \leq B$ the hook is fine; if $A > B$ the hook needs to be replaced:

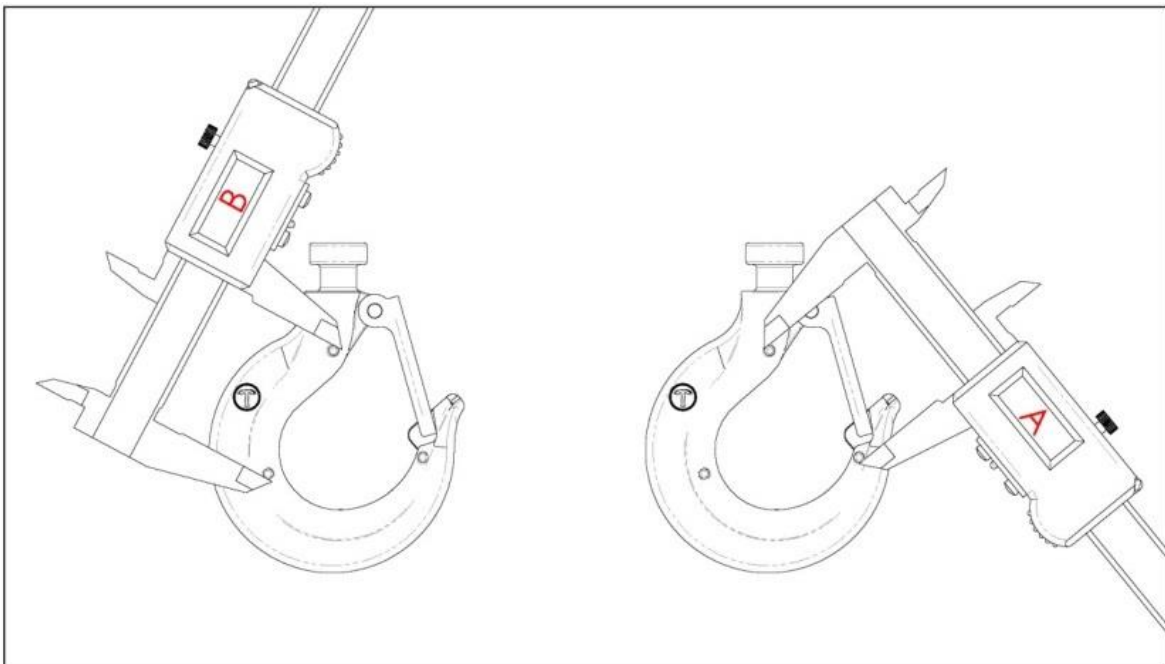

7. Maintenance

! WARNING

Never perform maintenance on the hoist while it is supporting a load.

Before performing maintenance attach a notice/tag to the block to indicate that it must not be used while maintenance is in progress.

Servicing and repairs should only be carried out by qualified, competent, and responsible people.

After performing any maintenance to the hoist, always perform a functional test before returning to service. After the replacement of components, a subsequent inspection by a competent person is obligatory!

Repair work may only be carried out by a specialist workshop that uses original Tiger spare parts.

Before handling lubricants, read the associated product health and safety data information sheet obtained from the lubricant supplier.



Load Chain

To determine if load chain should be continued in service, check gauge lengths and condition. Chain worn beyond the maximum allowable gauge length (as shown in Chapter 6), nicked, gouged or twisted chain should be replaced before returning the chain block to service.

In most cases, chain wear in the link points is caused by insufficient care of the chain. In order to ensure optimal lubrication of the link contact points, lubricate the chain at regular intervals with appropriate lubricant, taking into account the application, temperature range, corrosion resistant properties required and other relevant conditions.

It is recommended that you lubricate load chain at least weekly, or more frequently than normal depending on severity of service. Apply new lubricant over existing layer. Lubricate chain more frequently in a corrosive environment. Corrosion resistant chain is available for Tiger chain blocks as an option on TCB models.

A dry film lubricant, e.g. PTFE spray, should be used in environments where abrasives like sand, etc., occur. The service life of the load chain can be increased by careful lubrication to 20 - 30 times, compared with a chain that is not serviced.

When lubricating the chain, make sure the chain is in no-load condition so that the oil can reach the contact points (crown/saddle) of the chain links which are subject to wear. Chain link parts contacting each other must always be coated with lubricant otherwise increased wear on the chain results.

It is not sufficient to lubricate the chains on the outside as this does not ensure that a lubricant film can build up in the contact points.

Make sure that the load chain is lubricated over its entire length, also including the part of the chain in the housing of the hoist around the load sheave/wheel. Remove excess lubricant from the chain by wiping with a cloth.

When lubricating the chain, also check the chain for wear.

Clean dirty chains with acid free or water based solvent or a similar cleaning agent, to remove rust or abrasive dust build up. Never heat the chain.

! WARNING

Make sure that no lubricant can penetrate into the brake enclosure. This may result in failure of the brake.

Replacing the load chain

The load chain must be replaced by a new chain of the same dimensions and quality in the event of visible damage or deformations, or when the discarding status has been reached, at the latest.

A load chain to be discarded must only be replaced by an authorised competent person. Only fit load chains which have been approved by the manufacturer. Non-compliance with this specification will render the legal warranty or guarantee void with immediate effect.

If the chain links are not deformed, the chain can be replaced with the hoist in the suspended position as in the instructions below. Alternatively, remove the hoist from the suspension point and work on a bench. If the chain is jammed in the lifting unit the hoist must be removed and stripped.

Note: Replacement of a load chain must be documented!



Hoist with single fall

1. Only pull in the new chain in no-load condition (if the hoist is not loaded).
2. An open load chain link (split link) is required as a tool. It can be obtained by using an abrasive wheel to cut a section from an existing link with the same dimension. The length of the cut section must at least correspond to the thickness of the link.
3. Remove the bottom hook from the old load chain and suspend the open load chain link (split link) in the loose end of the load chain.
4. Suspend the new lubricated load chain also in the open link and pull it in (chain movement UP).
5. Do not fit a twisted chain. The welds must face outwards from the load sheave/wheel.
6. When the old load chain has passed through the hoist unit it can be detached together with the open chain link and the bottom hook can be fitted on the new load chain just pulled in.
7. Fix the slack end of the new load chain on the anchor on the housing or frame (depending on model) of the hoist.

Multi-fall hoists

1. Only pull in the new chain when the bottom block is unloaded, otherwise the bottom block may drop when the load chain is detached. Danger of injury!
2. An open load chain link (split link) is required as a tool. It can be obtained by using an abrasive wheel to cut a section from an existing link with the same dimension. The length of the cut section must at least correspond to the thickness of the link.
3. Detach the loaded-fall (tight/operational) end of the load chain from the top or bottom hook assemblies (depending on capacity).
4. Suspend the prepared, open load chain link in the now free load chain end.
5. Suspend the new, lubricated load chain also in the open link and pull it through the bottom block and the hoist unit (chain movement UP).
6. Do not fit a twisted chain. The welds must face outwards from the load sheave/ wheel.
7. When the old load chain has passed through the hoist unit it can be detached together with the open chain link.
8. Fix the loaded-fall (tight/operational) end of the new load chain on the housing/frame or on the bottom block (depending on model) of the hoist.
9. Fix the slack end of the idle fall on the hoist instead of the old load chain.

Before returning chain to service or after replacing a load chain, lubricate liberally with chain oil or equal lubricant. Remove excess lubricant from the chain by wiping with a cloth.

Note: Worn chain can be an indication of worn chain block components. For this reason, the chain block's chain guide roller and load sheave/wheel should be examined for wear and replaced as necessary when replacing worn chain.

! WARNING

Load chains are specially heat treated and hardened and should never be repaired.

The slack end of the idle fall must always be fitted to the chain end anchorage.

Using other than Tiger supplied or approved load chain may cause the chain to jam in the chain block and/or allow the chain to break and the load to drop. Due to the size requirements and physical properties, use only Tiger approved load chain in Tiger TCB or SS12 chain blocks.

Do not use replaced chain for other purposes such as lifting or pulling. Load chain may break suddenly without visual deformation. For this reason, cut replaced chain into short lengths to prevent use after disposal.

Failure to maintain clean and well lubricated load chain will void the manufacturer's warranty.



Hand Chain

Hand Chain should be cleaned, inspected and checked for damage.

Changing the length of the hand chain

The hand chain on a TCB chain block is normally supplied to hang 500mm shorter than the height of lift of the load chain. For particular applications it may be supplied at a different length or may need to be adjusted to a different length. Or if the height of lift has changed and the load chain replaced, the hand chain may need to be adjusted.

The hand chain may contain an unwelded link. This link can be placed in a vice and twisted open to facilitate changing chain or chain length. Please note that opening and closing of the connecting link more than twice is not recommended.

The hand chain may contain a special riveted Tiger hand chain joining link (HC-050-JL). This link can be removed by drilling the rivets out.

Use a new link to close the loose chain ends by bending it or use a Tiger hand chain joiner link and stainless steel rivets available from your Tiger supplier. For extending the hand chain, two new chain links or Tiger hand chain joiner links are required.

Note: See Chapter 6 Chain and Hooks for information about the orientation of the Tiger hand chain joiner link.

Note: Always remove or add an even number of chain links.

Note: Care must be taken to ensure that there is no twist in the hand chain loop.

Replacing the hand chain

Take the hand wheel cover off and replace the hand chain with a new hand chain loop.

Load Limiter

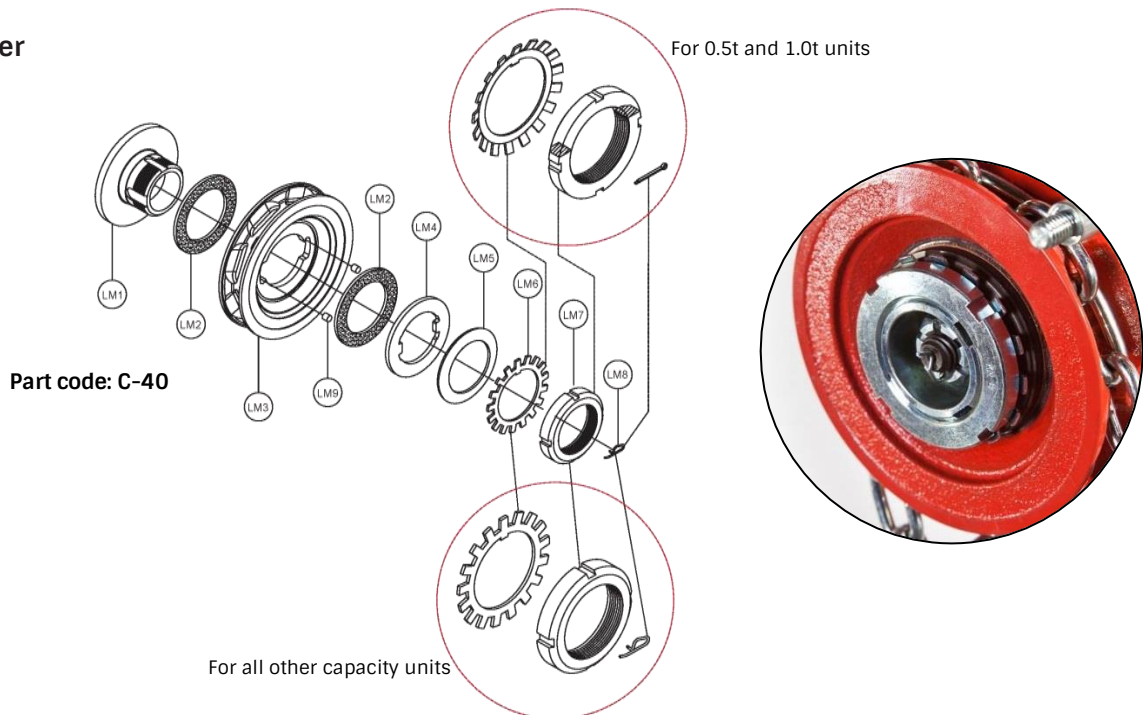



Your TCB or SS12 chain block may have been supplied with a load limiter, if this has been requested at the time of order.

The load limiter (C-40) is fitted to prevent hoist overload. The device consists of items LM1-LM9 and operates by limiting the amount of torque transmitted by the hand chain wheel. It is independent of the hoist brake.

If a load limiter is fitted, items LM1-7 and LM9 replace the standard hand chain wheel (C-28) and item LM8 (R clip (or split pin for 0.5t and 1.0t capacity units)) replaces the cotter/split pin (C-32) in the check nut. See Chapter 13 for explosion diagrams of chain blocks without load limiters and for the explosion diagram and parts list for the load limiter.

To set the load limiter:

If the load limiter components have been disassembled, they will need to be reassembled (as a C-40) as in the diagram above.

1. Place the assembled load limiter on the pinion shaft (C-07), in place of the standard hand wheel (C-28)
2. Tighten the castle/check nut (C-31) and insert the LM8 (R clip (or split pin for 0.5t and 1.0t capacity units)) as described in Chapter 5 – Inspection/Check the brake function Figure 1.
3. Fit the hand chain.
4. Suspend the chain block from a test machine, with a load cell in line to monitor the load.

The overload protection device is normally set to engage when a load of approximately 135% ($\pm 10\%$) of the WLL is lifted, unless otherwise specified during purchasing. Determine what your target overload limit is for the unit before you begin to set the overload mechanism.

5. A weight greater than the target load limit is required on the test bed to set the load limiter.
6. With the limiter set open (and LM6 tabs flat) start operating the hand chain in a clockwise direction.
7. The load limiter will start to slip when tension in the load chain has been applied.
8. Holding both sides of the hand chain in one hand to lock the hand wheel, use a load limiter tool to start tightening the locking nut (LM7).
9. Operate the hand chain again until the load limiter slips, observing the load cell reading as the load increases.
10. Repeat the process of tightening (LM7), as in steps 8 and 9, and the load will increase in increments until the target overload limit is showing on the load cell without any slippage.
11. Once the target load has been established lower and reload the hoist up to 10 times to ensure consistent readings.
12. One tab on the tab washer (LM6) will then need to be bent into a recess on locking nut (LM7) to secure the settings of the mechanism.
13. Operate the hoist up and down, lifting and lowering the load, to ensure the target overload is being consistently maintained.
14. Check that the hoist is operating correctly and refit the covers.

Depending on loads lifted or frequency of use, overload limiters will need to be reset from time to time.

Hooks

Lubricate the hook shank, the head within the hook yoke and the hook latch pivot points with the same lubricant used on load chain.

Pawls

When the chain block is disassembled for periodic inspections, check the C-25 pawls for free movement and apply a light coat of grease to the pawl shaft. Make sure that the pawl springs are seated correctly around the pawls and mounting points. The pawls should fully engage into the ratchet gear teeth in the correct orientation as in this image. Newer versions of the hoist have a dimple indicator on the pawl. The pawl is fitted with the dimple facing you.





Other Lubrication

When the chain block is disassembled for cleaning or repairs, the following locations should be lubricated using suitable grease:

- gears
- load sheave bearings
- load chain roller guides
- gear bearing bushes
- pinion shaft
- inner of ratchet gear being careful not to contaminate the braking surfaces.

The brake is designed to operate unlubricated. Do not use any grease or lubricant on the braking surfaces. When lubricating parts adjacent to the brake, do not use an excessive amount of lubricant as this could seep onto the brake surface.

The grease should be suitable for temperature ranges of -40°C (-40°F) to $+50^{\circ}\text{C}$ ($+122^{\circ}\text{F}$). It should take into account the application, temperature range, corrosion resistant properties required and other relevant conditions.

Thread lubricant or an anti-seize compound use is recommended for threaded shafts, capscrews and nuts. Unless otherwise stated, remove old lubricant, clean part with an acid free solvent and apply a new coating of lubricant to part before assembly.

! WARNING

Using any grease or lubricant on the braking surfaces will cause brake slippage and loss of load control which may result in injury and/or property damage. To avoid injury do not use any grease or lubricant on the braking surfaces. The brake is designed to operate unlubricated.

Alignment of Gears during Reassembly

For 500kg, 1.0t, 1.5t, 2.0t lite, 2.0t, 3.0t twin fall, 5t and 8t capacity units:

The teeth between two marks at the gear spline must be on the horizontal centreline, one facing towards the centre and one facing outward, as shown. (Figure 1)

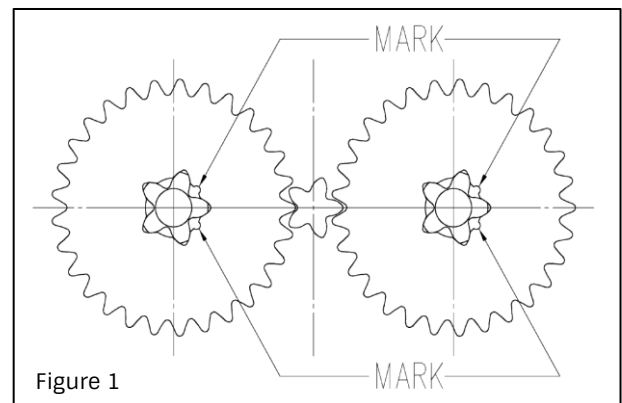

Figure 1

For 3.0t single fall, 10.0t, 15t, 20t and 30t capacity units:

Note the marks "0" on the gears. For the right gear, place the "0" mark next to the pinion shaft spline on the horizontal centreline. For the left gear, place the "0" mark to the top on the vertical centreline as shown. (Figure 2)

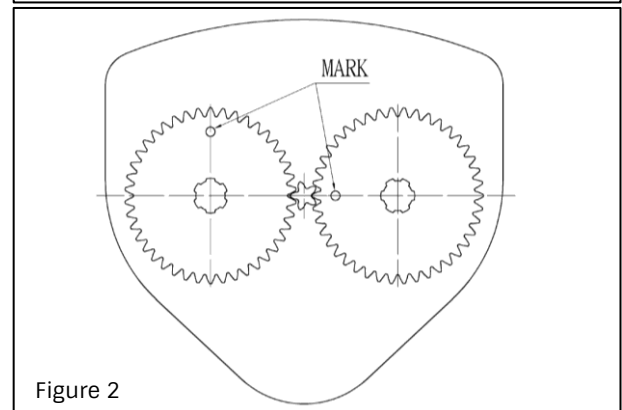

Figure 2



Replacing the Brake Discs

Brake discs should be uniform thickness and the thickness should be greater than or equal to 1.5mm. They should be replaced when the thickness is less than 1.5mm. Pull out the old ratchet gear and brake discs, which may have been provided as a bonded unit. When you are putting in the new ratchet gear and brake discs, the brake pawls need to be held back as the new ratchet gear is inserted. Make sure that the pawl springs are seated correctly around the pawls and mounting points. The pawls should fully engage into the ratchet gear teeth in the correct orientation. If the brake discs are bonded with the ratchet gear, the entire bonded unit will need to be replaced. See the Pawl section earlier in this chapter for the correct orientation of the pawls.

Exterior Finish

The exterior surfaces of the chain blocks have a durable, scratch resistant finish. Normally, the exterior surfaces can be cleaned by wiping with a cloth. Paint damage should be touched up in order to avoid corrosion. All joints and sliding surfaces should be slightly greased. In the case of heavy contamination, the unit must be cleaned using acid free or water based solvent or a similar cleaning agent.

Preventative Maintenance

In addition to the periodic inspection procedure, a preventative maintenance program should be established to prolong the useful life of the chain block and maintain its dependability and continued safe use. The program should include the periodic inspections with particular attention being paid to the lubrication of various components using the recommended lubricants.

Testing

Before using, all altered, repaired, or used chain blocks that have not been operated for the previous 12 months, should be tested by the user for proper operation. First test the unit without a load and then with a light load of 2% to be sure that the chain block operates properly and that the brake holds the load when the hand chain is released. Next test with a load of 100% rated capacity. In addition, chain blocks in which load sustaining parts have been replaced should be tested with 100% of rated capacity by or under the direction of an appointed person and a written report prepared for record purposes.

! WARNING

Use only Tiger supplied replacement parts. Parts may look alike; however Tiger parts are made of specific materials, processed to achieve specific properties or precisely machined to fit only Tiger hoists.

Any repairs to this chain block must be undertaken by a suitably qualified and competent person. Following any repairs, this chain block must be tested in line with relevant standards prior to its reintroduction to service.

8. Transport, Storage, Decommissioning and Disposal

Transporting the unit:

- Do not drop or throw the unit, always deposit it carefully.
- Hand chains and load chains must be transported in a way to avoid knotting and formation of loops.
- Use suitable transport means. These depend on the local conditions.

Storing or temporarily taking the unit out of service:

To ensure the continuing integrity of the unit you should store the unit in conditions that do not lead to damage or deterioration. Therefore:

- Always store the hoist unloaded.
- The hoist should be secured against unauthorised and unwarranted use.



- Store the unit in a clean and dry place.
- Protect the unit including all accessories against contamination, humidity and damage by means of a suitable cover.
- Protect against corrosion.
- Wipe off all dirt and water.
- A light oil film should be applied to the chains, hook pins and hook latch pins.
- Since the brake disks may freeze at temperature below 0°C, the unit should be stored with closed brake. Turn the hand chain wheel clockwise to this effect and hold the load fall at the same time.
- If the unit is to be used again after it has been taken out of service, it must first be inspected again by a competent person.

Disposal

When the product comes to the end of its lifecycle, after taking the unit out of service, recycle or dispose of the parts of the unit respecting local and national environmental regulations.

9. Manufacturer Testing and Verification

This product was manufactured under our single-unit control of quality and was passed with strict inspection in accordance with our inspection standards.

Capacity (tonne)	WLL (kg)	Test Load (kg)
0.5	500	750
1	1000	1500
1.5	1500	2250
2	2000	3000
3	3000	4500
5	5000	7500
8	8000	12000
10	10000	15000
15	15000	22500
20	20000	25000
30	30000	37500

Declaration of Conformity

Products are tested in line with the requirements within applicable sections of the European standard BS EN 13157:2004+A1:2009, the Australian standard AS1418.2, the American standard ANSI/ASME B30.16, and the South African standard SANS 1594. Chain blocks supplied with slipping clutch overload protection are compliant with the Norwegian Standard NORSOK R-002. All items comply with the essential health and safety requirements of the Machinery Directive 2006/42/EC. Tiger chain blocks are third party verified by SGS Certificate Number MDC 1302.





10. Troubleshooting

Problem	Cause	Solution
Chain is jammed	<p>Load is not being pulled in a vertical direction</p> <p>Pull is at an angle greater than 60°</p> <p>Load swivel has ceased operating</p> <p>Block is dirty, or hampered with foreign matter</p> <p>Fall of chain is tangled</p> <p>Block is overloaded</p> <p>Brake mechanism has jammed</p>	<p>Line load to be positioned vertically</p> <p>Reduce angle of pull</p> <p>a) Unload load and de-swivel b) Replace hook assembly</p> <p>Refer to maintenance and repair section of this manual</p> <p>Unravel and straighten chain</p> <p>Check the load chain for elongation and replace as required. Load block to recommended capacity only</p> <p>Return to supplier or authorised service centre for repair</p>
Block Seized	<p>Wear and tear</p> <p>Poor maintenance and inspection</p> <p>Poor storage and handling</p> <p>Block is overloaded</p>	<p>Replace block</p> <p>Refer to manual for maintenance and inspection details</p> <p>Always store unit in a dry and clean area</p> <p>Load block to rated capacity only</p>
Slippage of load	<p>Brake mechanism worn</p> <p>Block is overloaded</p>	<p>Inspect brake (Chapter 5 Inspection). Replace brake discs or repair brake as described in Chapter 7 Maintenance.</p> <p>Load block to rated capacity only</p>
Block not braking	Brake mechanism worn	Return to supplier for repair and testing
Load chain catches or jams	<p>Damaged load chain, pinion shaft, gears or sheaves.</p> <p>Load chain not installed properly (twisted, kinked or "capsized").</p>	<p>Disassemble hoist, inspect and repair or replace damaged components.</p> <p>Remove load chain and re-install.</p>
Hand chain catches or jams	<p>Damaged hand chain, hand chain wheel, pinion shaft, gears, load chain, sheaves.</p> <p>Hand chain not installed properly (twisted or kinked).</p>	<p>Disassemble hoist, inspect and repair or replace damaged components.</p> <p>Remove hand chain and re-install.</p>
Hook Latch does not work.	<p>Latch broken.</p> <p>Load hook bent or twisted.</p>	<p>Replace hook latch.</p> <p>Inspect load hook as described in Chapter 5 Inspection. Replace if necessary.</p>





11. Product Warranty and Warnings

Definitions

'Customer' means the individual, firm, company or other party with whom the Company contracts;

'Company' means Tiger Lifting UK Limited or Woo Sing Industrial Co., Ltd;

'Contract' the contract between the Company and the Customer for the sale and purchase of this product;

'Defective Goods' goods, parts or materials, which by reason of fault or incorrect design or workmanship, are found to be defective or fail or are unable to perform in accordance with a Contract;

One Year Limited Warranty

The Company makes every effort to assure that its products meet high quality and durability standards and extends the following warranty to the Customer of new products manufactured by the Company:

1. The Company warrants that this product, when shipped, shall be free from defects in materials and workmanship under normal use and service and the Company shall, at its election, repair or replace free of charge any Defective Goods, provided that all claims for defects under this warranty shall be made in writing immediately upon discovery and, in any event, within one (1) year from the date of purchase of this product by the Customer and provided, further, that Defective Goods shall be kept for examination by the Company or its authorised agents or returned to the Company or an authorised service centre upon request by the Company.
2. The Company does not warrant components of products provided by other manufacturers. However to the extent possible, the Company will assign to the "Purchaser" applicable warranties of such other manufacturers.
3. Except for the repair or replacement mentioned in (1.) above, which is the Company's sole liability and Customer's exclusive remedy under this warranty, the Company shall not be responsible for any other claims arising out of the purchase and use of this product, regardless of whether the Customer's claims are based on breach of contract, tort (including negligence), breach of statutory duty, or otherwise, including claims for any loss of profit, goodwill or business opportunity or any indirect or consequential loss arising under or in connection with the Contract.
4. This one year limited warranty is conditional upon the installation, maintenance and use of this product pursuant to the product manuals prepared in accordance with content instructions by the Company. The warranty on this product does not apply to defects due directly or indirectly to misuse, abuse, negligence or accidents. This warranty does not apply if the product has been subjected to improper fittings, alignment or maintenance.
5. The Company shall not be responsible for any loss or damage caused by transportation, prolonged or improper storage or normal wear and tear of this product or for loss of operating time.
6. This warranty shall not apply to this product if it has been fitted with or repaired with parts, components or items not supplied or approved by the Company or which have been modified or altered.
7. The Company limits all implied warranties to the period specified above from the date the product was purchased by the Customer.
8. Except as stated herein, any implied warranties or merchantability and fitness are excluded.

If our inspection discloses a defect, the Company will repair, replace the product or refund the purchase price, if we cannot readily or quickly provide a repair or replacement and if you are willing to accept such refund. The Company will return repaired or replacement products at The Company's expense, but if it is determined there is no defect, or that the defect resulted from causes not within the scope of Tiger Lifting's warranty, then the Customer must bear the cost of storing and retrieving the product.

! WARNING

The use of this product is beyond the control of Tiger Lifting. The warranty of this product is limited to the replacement cost of this product should it be found to be defective in material and/or workmanship. The warranty is void if the chain block is damaged, worn or used improperly. Normal wear and tear is not considered grounds for replacement. The Tiger Lifting product warranty does not apply where there has been excessive overloading of the chain block.

Disclaimer

We believe that the information in this document, including technical information and any advice, is reliable although we give no guarantee as to its accuracy or completeness. The user of our products must determine if the product, either used alone or conjunction with other products, is suitable for their purpose and assumes all risk and liability in connection with those decisions. We have made every effort to make sure this document is accurate. The information contained in this document does not form part of any contract.

Please also refer to our terms and conditions which can be found at: www.tigerlifting.com/terms-conditions/





12. Technical Data

Chain blocks

Product Code	Capacity (tonne)	Effort (kg)	Dimensions (mm)							Load Chain		Standard HOL (m)	Mass @ standard HOL (kg)	Extra mass per metre HOL (kg)
			A	B	D	E	F1	F2	G	Diameter (mm)	No. of falls			
CB-0050	0.5	21	93	66	52	78	24	38	305	∅6.3	1	3	10.8	1.86
CB-0100	1.0	25	93	66	63	87	28	45	340	∅6.3	1	3	11.8	1.86
CB-0150	1.5	32	98	73	78	102	34	51	385	∅7.1	1	3	16.2	2.10
CB-0200	2.0	34	101	79	87	113	35	53	420	∅8.0	1	3	20.0	2.39
CB-020L	2.0	42	98	73	78	102	35	53	399	∅7.1	1	3	16.7	2.10
CB-0300	3.0	38	109	84	98	157	36	56	550	∅10.0	1	3	30.6	3.17
CB-030T	3.0	34	98	73	60	148	36	56	465	∅7.1	2	3	23.3	3.20
CB-0500	5.0	37	101	79	122	209	49	70	575	∅8.0	3	3	37.8	5.17
CB-0800	8.0	37	101	79	140	238	51	78	745	∅8.0	4	3	64.0	6.56
CB-1000	10.0	40	109	84	153	263	54	87	660	∅10.0	3	3	64.0	7.54
CB-1500	15.0	41	109	84	225	378	59	81	840	∅10.0	5	3	128.5	11.85
CB-2000	20.0	43	161	90	148	360	81	110	1050	∅10.0	6	3	178.7	14.20
CB-200T	20.0	43	161	161	383	383	81	110	1050	∅10.0	6	3	210.4	15.20
CB-3000	30.0	42	220	220	388	388	91	135	1200	∅10.0	10	3	306.9	23.80

Tolerance for capacities below 10t ±1.0mm

Tolerance for capacities 10t and above ±1.5mm

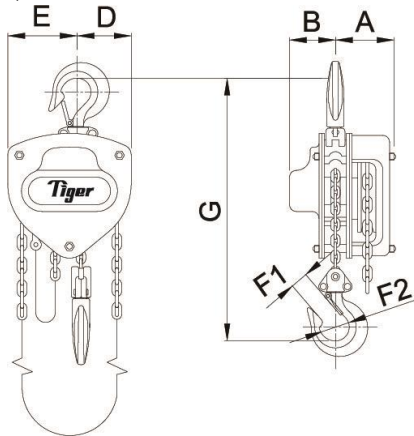

0.5t - 2.0t

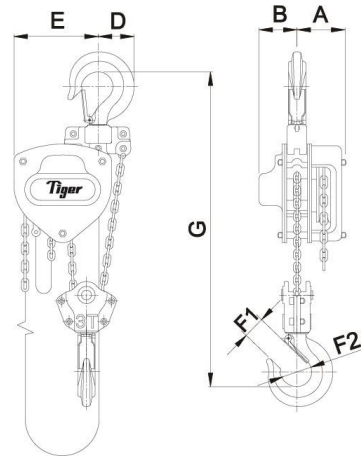

3.0t twin fall

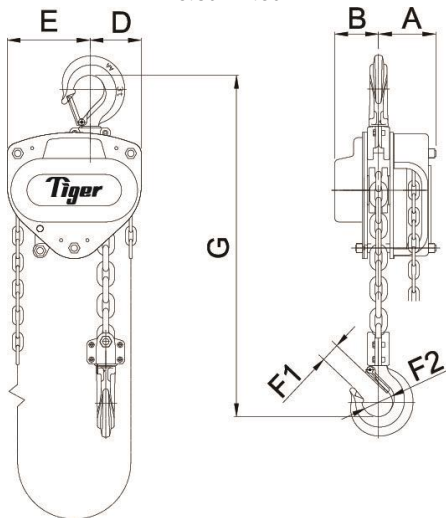

3.0t single fall

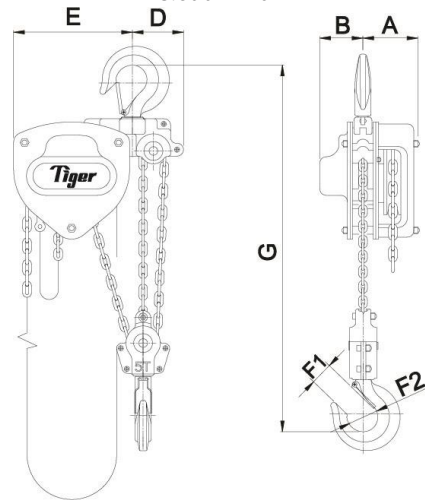

5.0t





Tiger

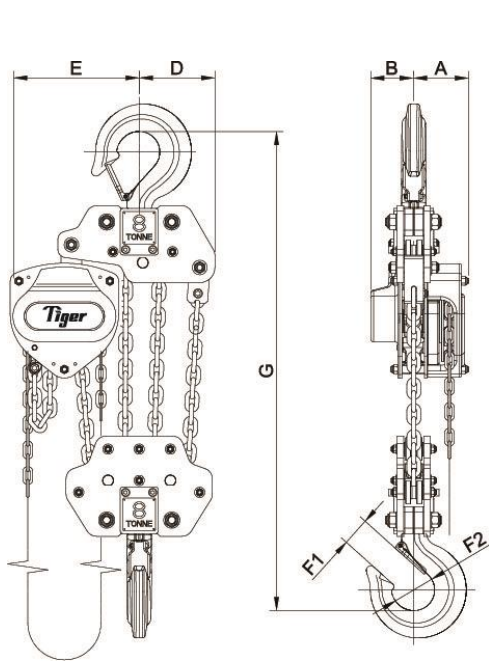

8.0t

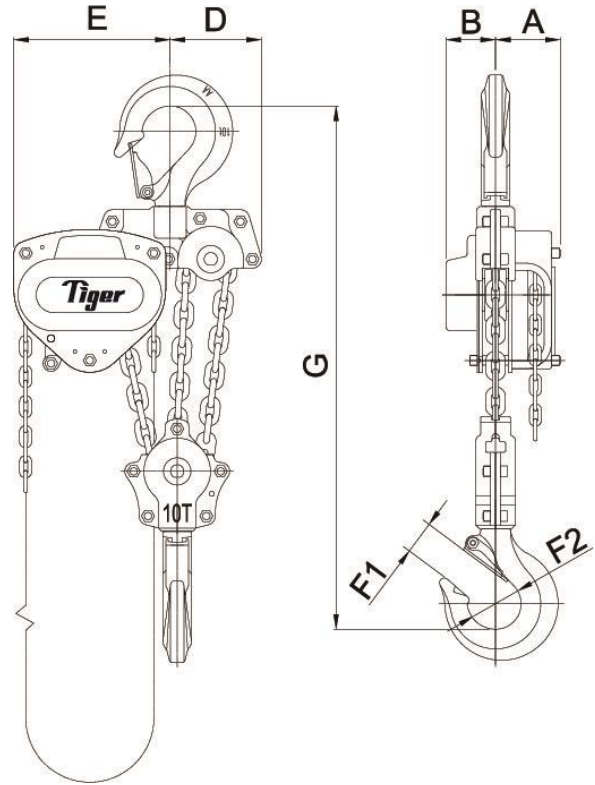

10.0t

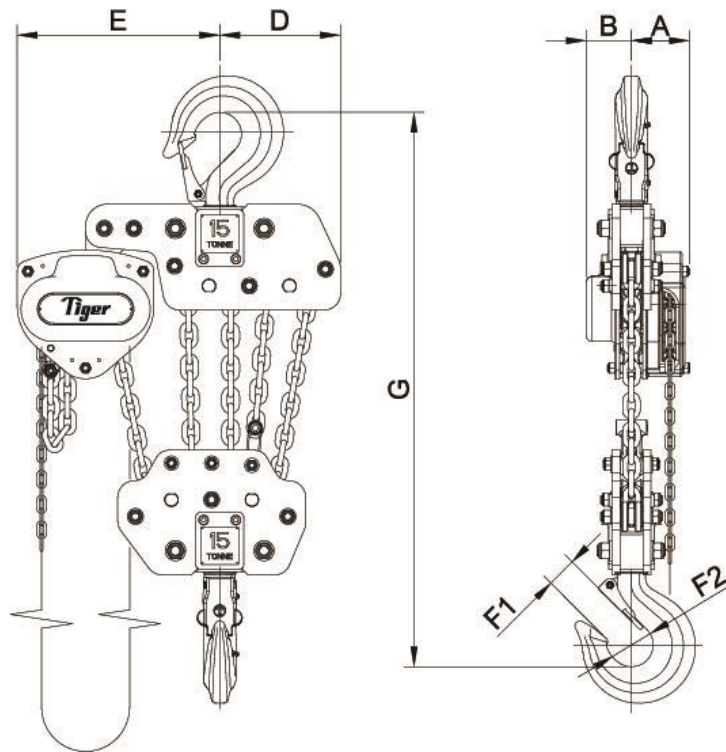

15.0t





Tiger

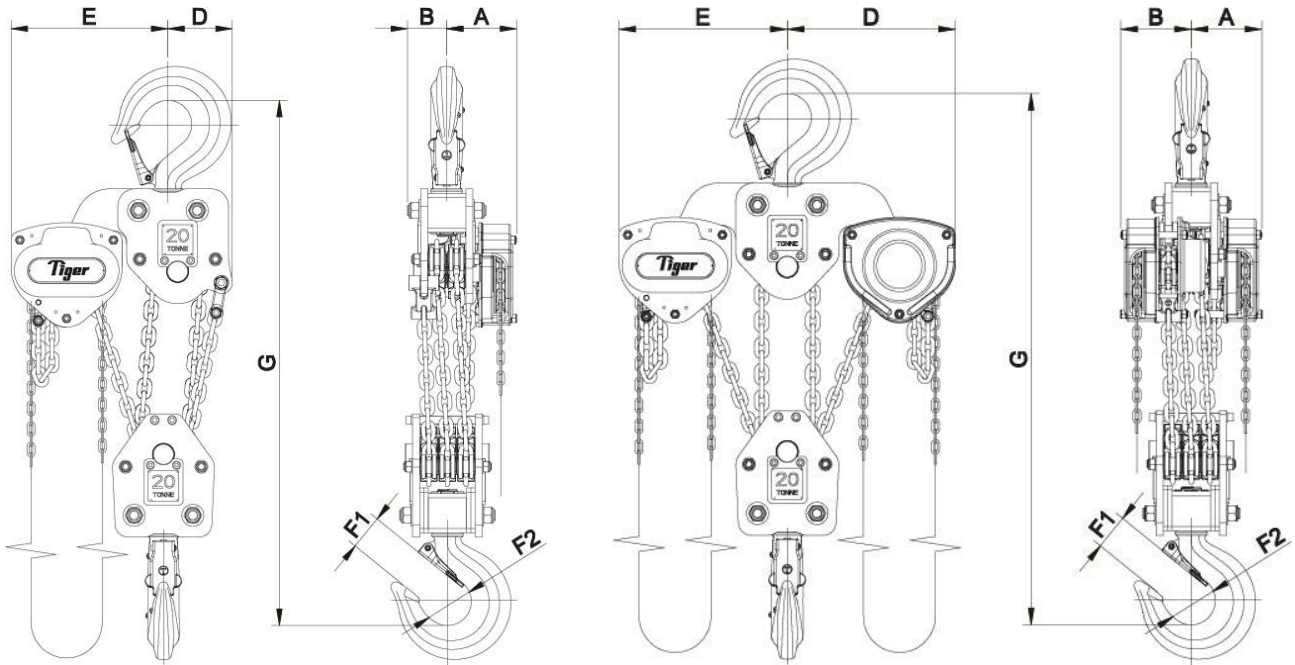

20.0t

20.0t twin head

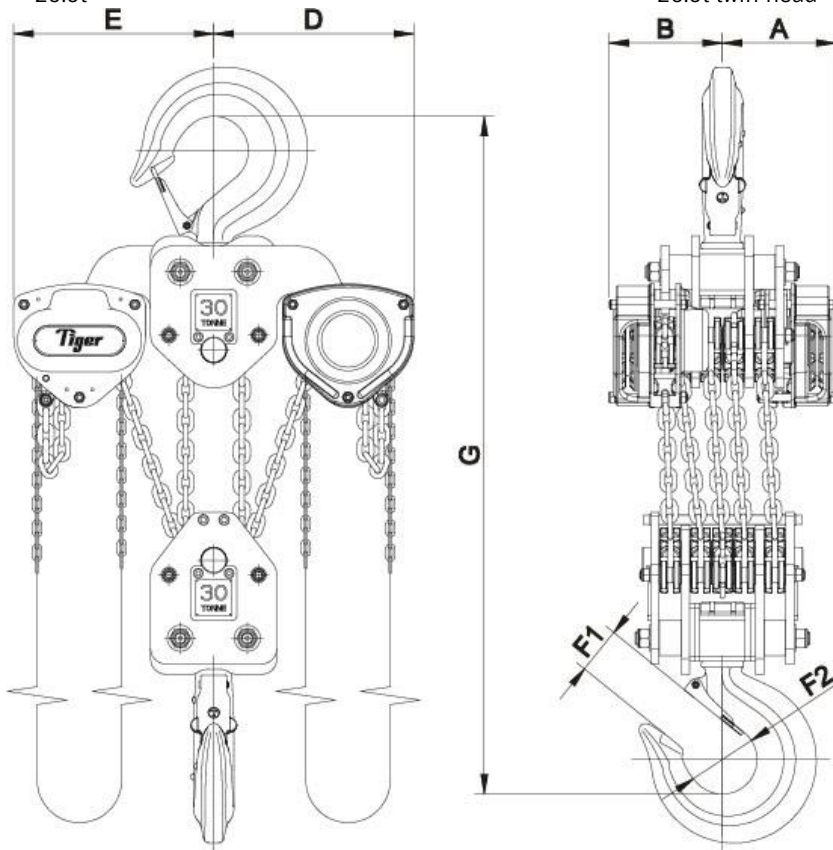

30.0t





Hooks

The following table shows the normal measurements for the Tiger hooks and the discard limits.

Capacity (Tonnes)	Collar measurements (mm)				Hook thickness at point shown in diagram (mm)				Hook throat Opening (mm)		"EZ Check" measurement (mm)	
	a		b		c		d		e		f	
	Normal	Discard \geq	Normal	Discard \leq	Normal	Discard \leq	Normal	Discard \leq	Normal	Discard \geq	Normal	Discard \geq
0.5	8	8.5	13.5	12.8	19	18	15	14	29	32	47	50
1.0	8	8.5	13.5	12.8	23	21.5	17	16	34	37	52	55
1.5	10	10.5	15.5	14.7	26	24.2	21	19.5	39	43	59	63
2.0	10	10.5	17.5	16.6	30	28.2	22	20.5	42	47	64	69
3.0	12.5	13.5	20	19	37	35	32	30	42	47	76	81
5.0	19	20.5	30	28.5	43	40.5	36	34	58	63.5	86	91.5
8.0	21.7	23	33	31.4	50	47	43	40.5	60	69	110	119
10.0	20	21.5	33	31.4	52	49	48	45	70	78	121	129
15.0	-	-	36	34.2	67	63	60	57	67	80	130	143
20.0	-	-	48	45.6	77	72.5	72	68	90	105	162	177
30.0	-	-	56	53.2	94	89	78	73.5	102	120	177	195

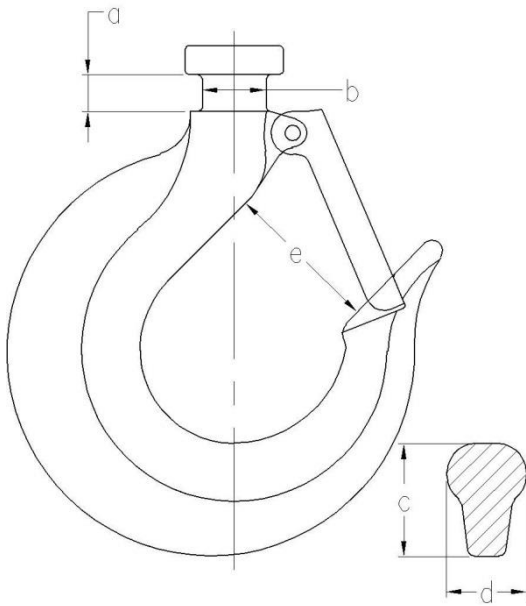

Traditional Tiger Hooks

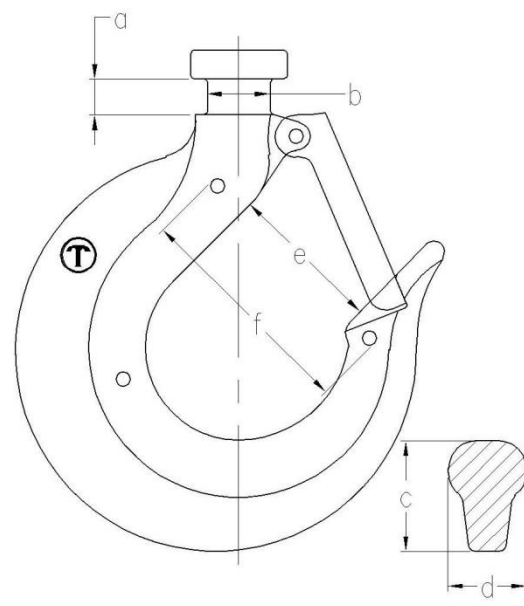

Tiger Hooks with new "EZ Check"
3 point marking system



Newer models of the TCB are fitted with the patent pending Tiger “EZ check” 3 point marking system. With this system a quick check that the A and B measurements are the same (as shown in the diagram below) will indicate if the hooks have stretched. If $A \leq B$ the hook is fine; If $A > B$ the hook needs to be replaced:

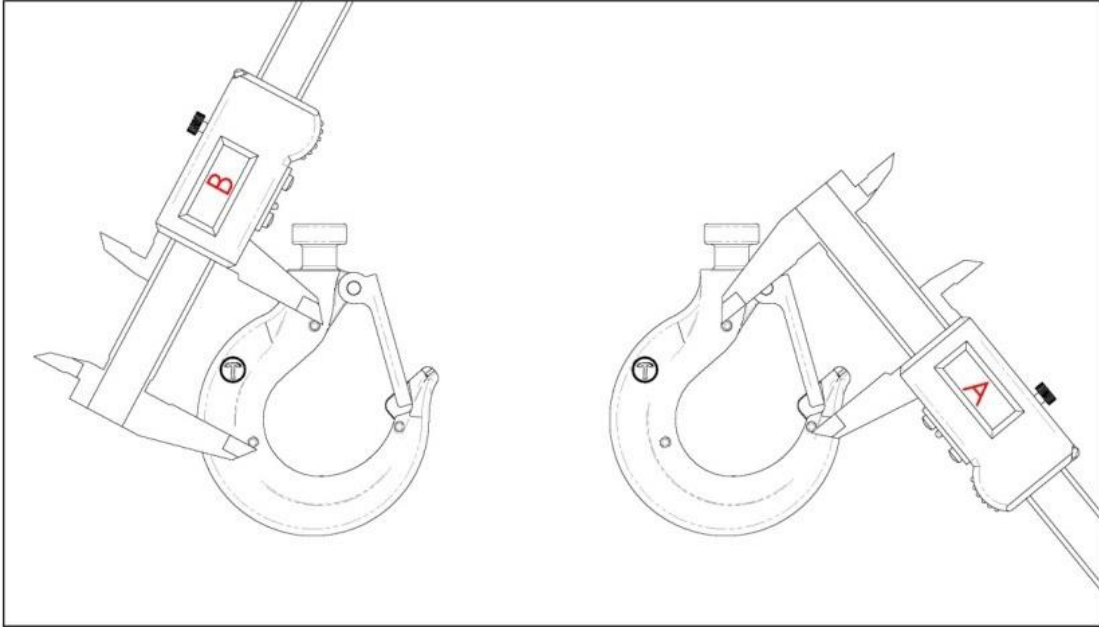

In addition to the above checks, more than a 10° twist from the plane of hook is enough to warrant replacement of the hook.

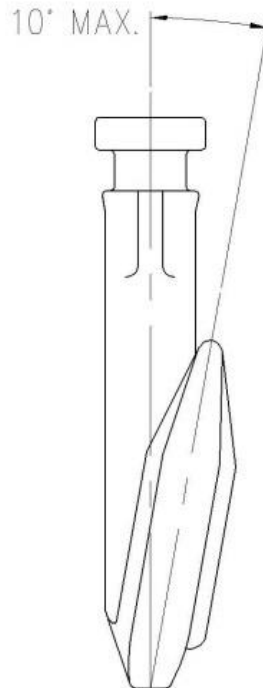



13. Exploded diagrams

For 500kg, 1.0t, 1.5t, 2.0t, 3.0t twin fall, 5t capacity units:

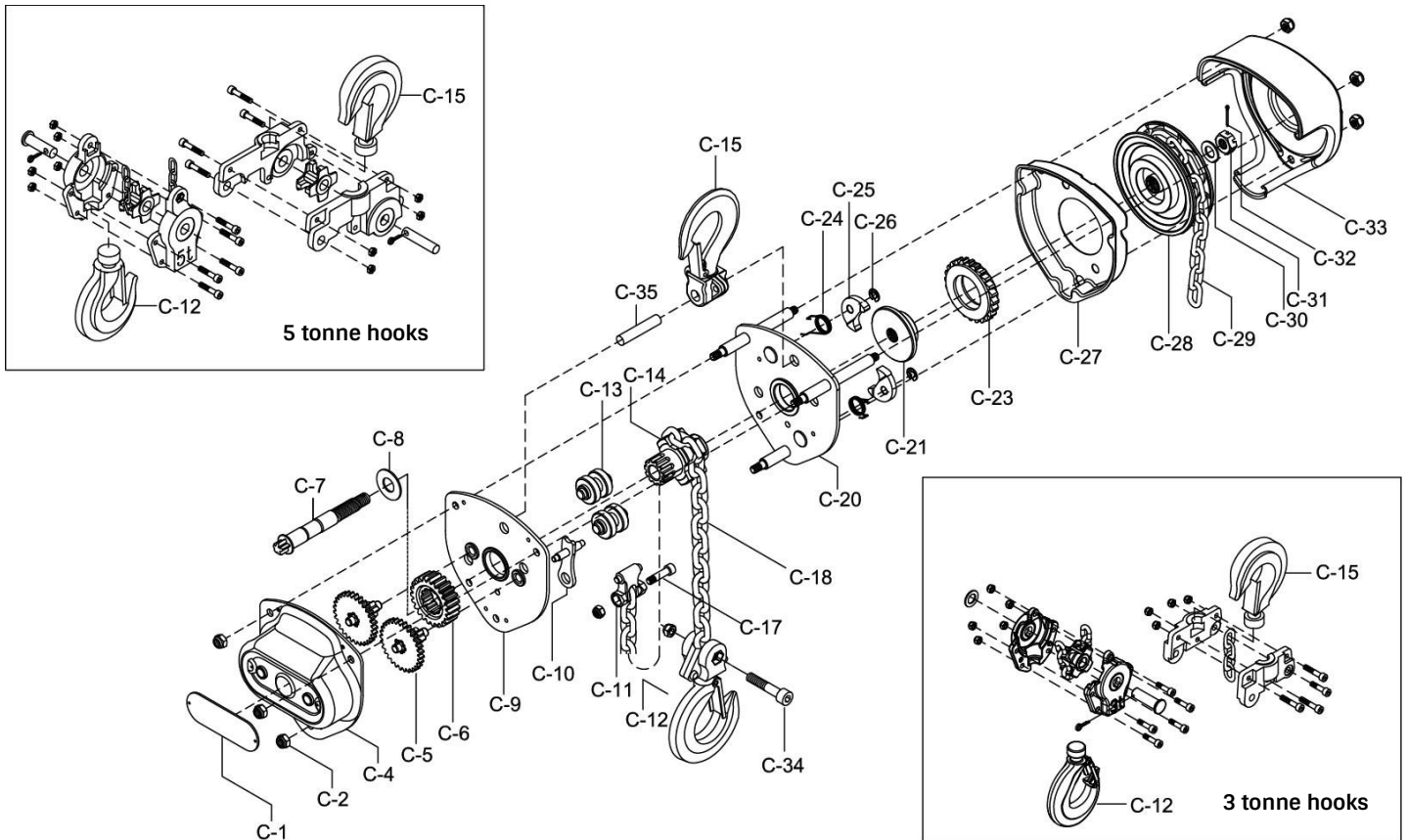

Part No.	Qty	Part Name	Part No.	Qty	Part Name	Part No.	Qty	Part Name
C-1	1	Label	C-13	2	Load Chain Guide	C-27	1	Brake Cover
C-2	6	Nut	C-14	1	Load Sheave	C-28	1	Hand wheel
C-4	1	Gear Cover	C-15	1	Top Hook Assembly	C-29	1	Hand Chain
C-5	2	Pinion (with Pinion Gear)	C-17	1	Chain-End-Fixing Pin	C-30	1	Washer for Pinion Shaft Nut
C-6	1	Load Gear	C-18	1	Load Chain	C-31	1	Check/Castle Nut
C-7	1	Pinion Shaft	C-20	1	Wheel-side Plate Assembly	C-32	1	Cotter/Split Pin for Check Nut
C-8	1	Washer	C-21	1	Disc Hub	C-33	1	Hand wheel Cover
C-9	1	Gear-side Plate	C-23	1	Brake Discs/ Ratchet Gear (bonded)*	C-34	1	Bottom Hook Pin
C-10	1	Chain Stripper	C-24	2	Pawl Spring	C-35	1	Top Hook Pin
C-11	1	Load Chain Anchoring	C-25	2	Pawl			
C-12	1	Bottom Hook Assembly	C-26	2	Snap Ring for Pawl Pin			

*The C-23 Brake Discs/Ratchet Gear will generally come as a bonded unit (C-2223) but sometimes they may be separate parts (2xC-22, 1xC-23).





For 3.0t single fall and 10.0t capacity units:

10 tonne top hook

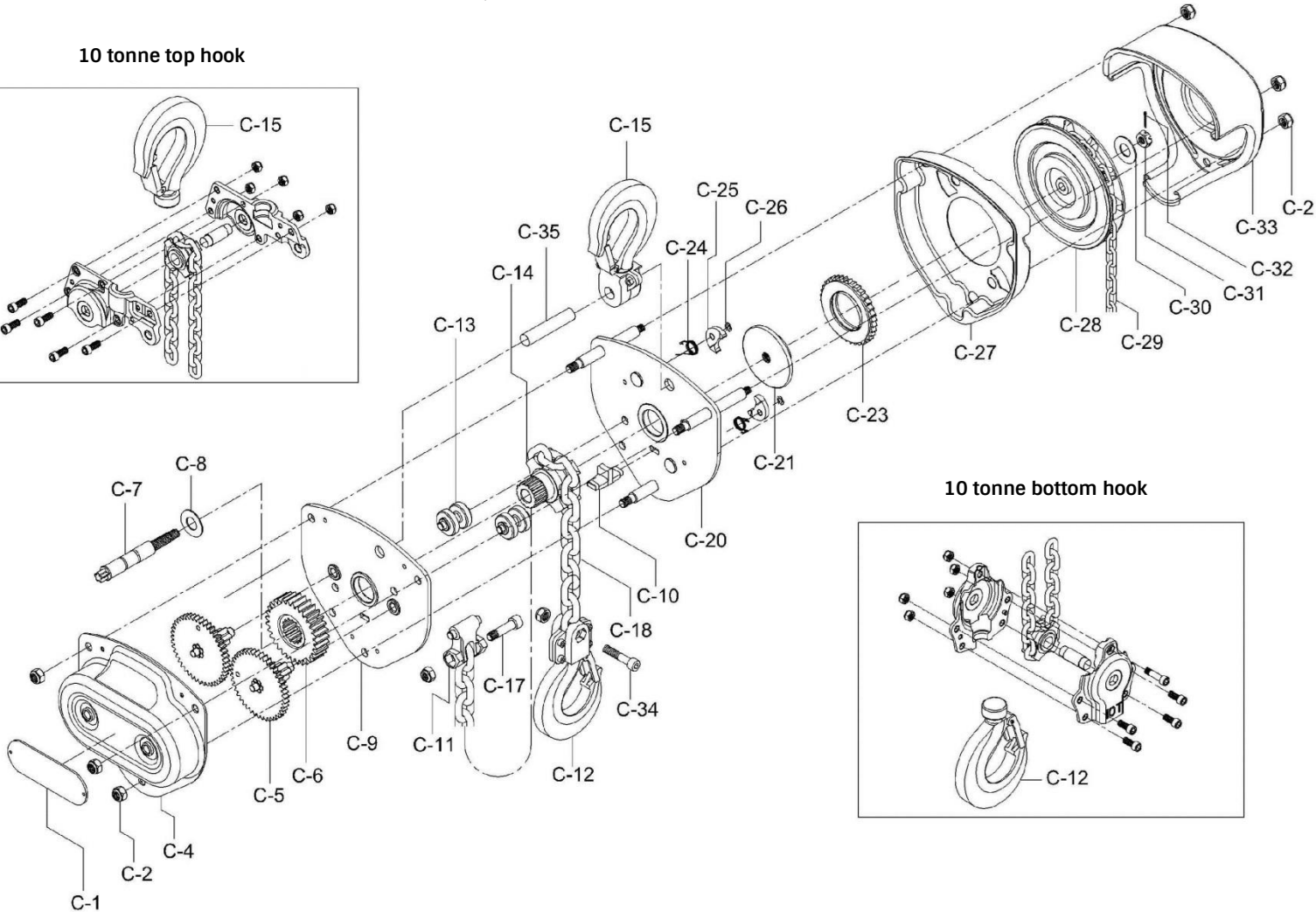
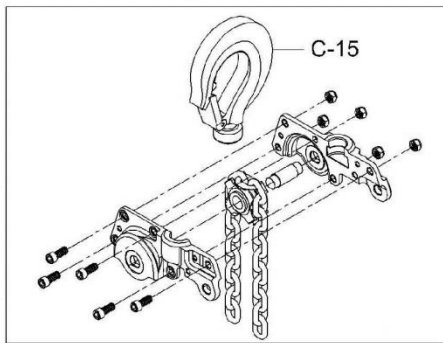

10 tonne bottom hook

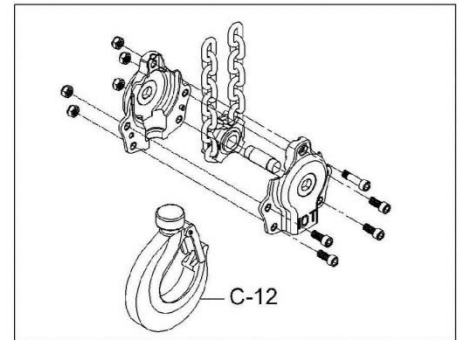

Part No.	Qty	Part Name	Part No.	Qty	Part Name	Part No.	Qty	Part Name
C-1	1	Label	C-13	2	Load Chain Guide	C-27	1	Brake Cover
C-2	6	Nut	C-14	1	Load Sheave	C-28	1	Hand wheel
C-4	1	Gear Cover	C-15	1	Top Hook Assembly	C-29	1	Hand Chain
C-5	2	Pinion (with Pinion Gear)	C-17	1	Chain-End-Fixing Pin	C-30	1	Washer for Pinion Shaft Nut
C-6	1	Load Gear	C-18	1	Load Chain	C-31	1	Check/Castle Nut
C-7	1	Pinion Shaft	C-20	1	Wheel-side Plate Assembly	C-32	1	Cotter/Split Pin for Check Nut
C-8	1	Washer	C-21	1	Disc Hub	C-33	1	Hand wheel Cover
C-9	1	Gear-side Plate	C-23	1	Brake Discs/ Ratchet Gear (bonded)*	C-34	1	Bottom Hook Pin
C-10	1	Chain Stripper	C-24	2	Pawl Spring	C-35	1	Top Hook Pin
C-11	1	Load Chain Anchoring	C-25	2	Pawl			
C-12	1	Bottom Hook Assembly	C-26	2	Snap Ring for Pawl Pin			

*The C-23 Brake Discs/Ratchet Gear will generally come as a bonded unit (C-2223) but sometimes they may be separate parts (2xC-22, 1xC-23).





For 8t capacity unit:

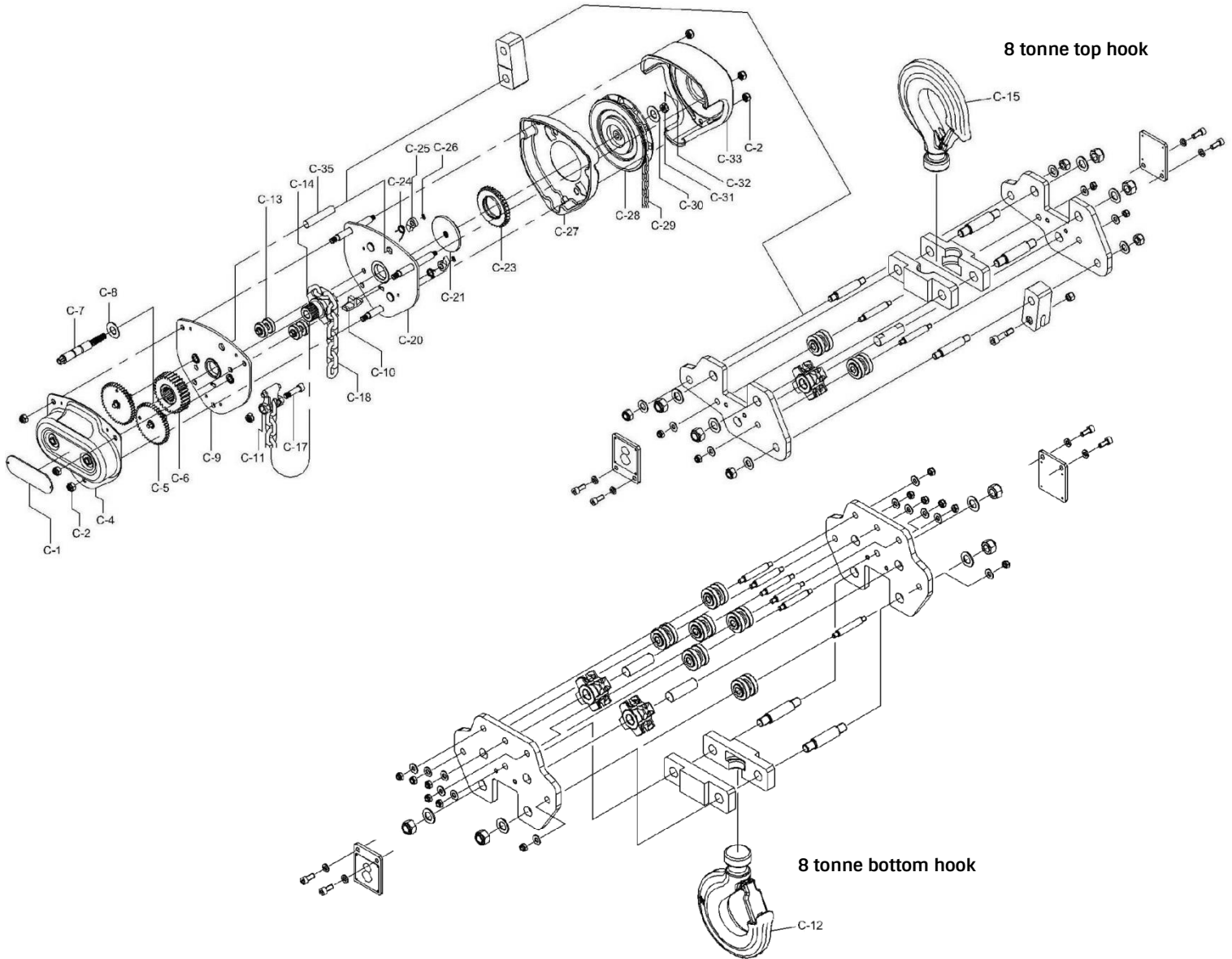

Part No.	Qty	Part Name	Part No.	Qty	Part Name	Part No.	Qty	Part Name
C-1	1	Label	C-12	1	Bottom Hook Assembly	C-25	2	Pawl
C-2	6	Nut	C-13	2	Load Chain Guide	C-26	2	Snap Ring for Pawl Pin
C-4	1	Gear Cover	C-14	1	Load Sheave	C-27	1	Brake Cover
C-5	2	Pinion (with Pinion Gear)	C-15	1	Top Hook Assembly	C-28	1	Hand wheel
C-6	1	Load Gear	C-17	1	Chain-End-Fixing Pin	C-29	1	Hand Chain
C-7	1	Pinion Shaft	C-18	1	Load Chain	C-30	1	Washer for Pinion Shaft Nut
C-8	1	Washer	C-20	1	Wheel-side Plate Assembly	C-31	1	Check/Castle Nut
C-9	1	Gear-side Plate	C-21	1	Disc Hub	C-32	1	Cotter/Split Pin for Check Nut
C-10	1	Chain Stripper	C-23	1	Brake Discs/ Ratchet Gear (bonded)*	C-33	1	Hand wheel Cover
C-11	1	Load Chain Anchoring	C-24	2	Pawl Spring	C-35	1	Top Hook Pin

*The C-23 Brake Discs/Ratchet Gear will generally come as a bonded unit (C-2223) but sometimes they may be separate parts (2xC-22, 1xC-23).





For 15t capacity unit:

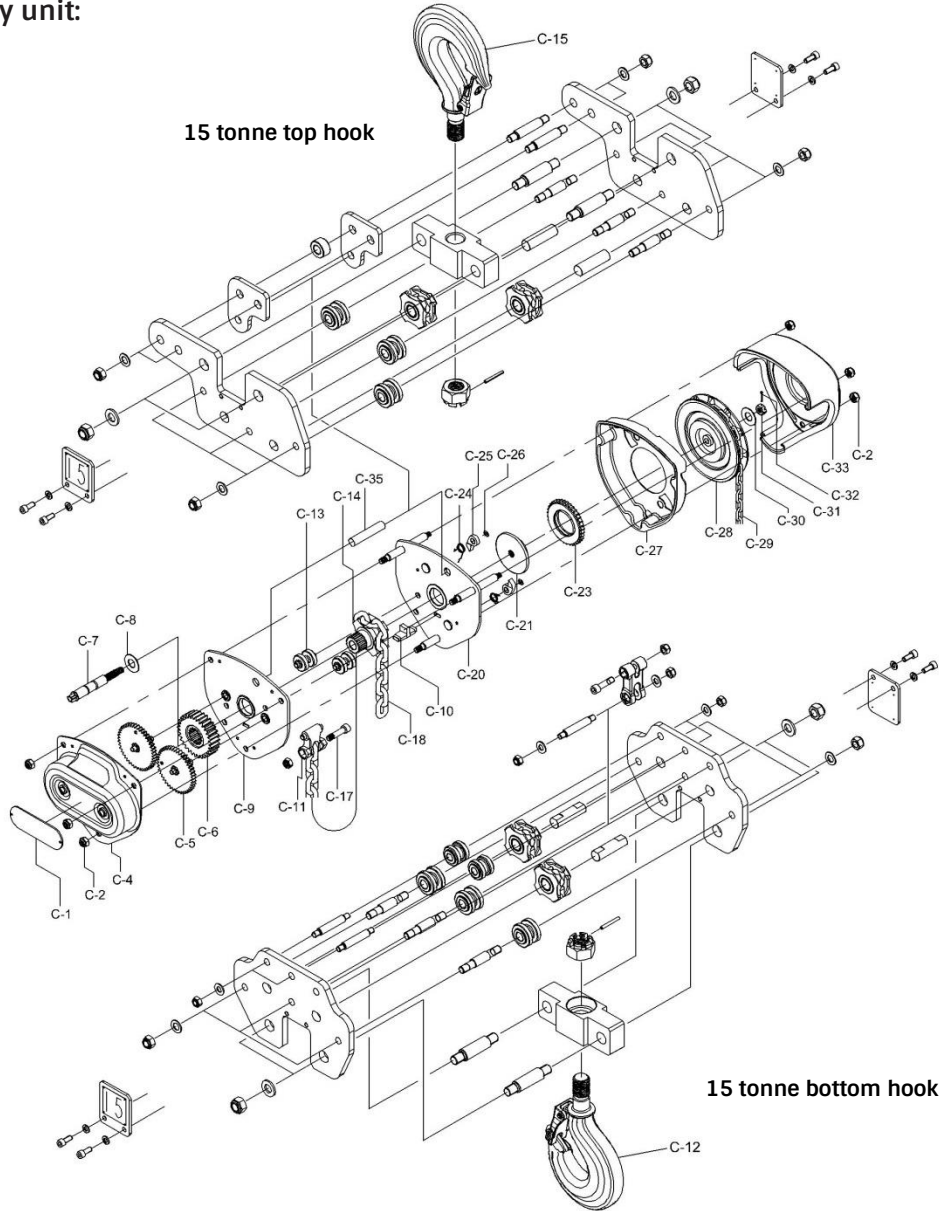

Part No.	Qty	Part Name	Part No.	Qty	Part Name	Part No.	Qty	Part Name
C-1	1	Label	C-12	1	Bottom Hook Assembly	C-25	2	Pawl
C-2	6	Nut	C-13	2	Load Chain Guide	C-26	2	Snap Ring for Pawl Pin
C-4	1	Gear Cover	C-14	1	Load Sheave	C-27	1	Brake Cover
C-5	2	Pinion (with Pinion Gear)	C-15	1	Top Hook Assembly	C-28	1	Hand wheel
C-6	1	Load Gear	C-17	1	Chain-End-Fixing Pin	C-29	1	Hand Chain
C-7	1	Pinion Shaft	C-18	1	Load Chain	C-30	1	Washer for Pinion Shaft Nut
C-8	1	Washer	C-20	1	Wheel-side Plate Assembly	C-31	1	Check/Castle Nut
C-9	1	Gear-side Plate	C-21	1	Disc Hub	C-32	1	Cotter/Split Pin for Check Nut
C-10	1	Chain Stripper	C-23	1	Brake Discs/ Ratchet Gear (bonded)*	C-33	1	Hand wheel Cover
C-11	1	Load Chain Anchoring	C-24	2	Pawl Spring	C-35	1	Top Hook Pin

*The C-23 Brake Discs/Ratchet Gear will generally come as a bonded unit (C-2223) but sometimes they may be separate parts (2xC-22, 1xC-23).





For 20t single head capacity unit:

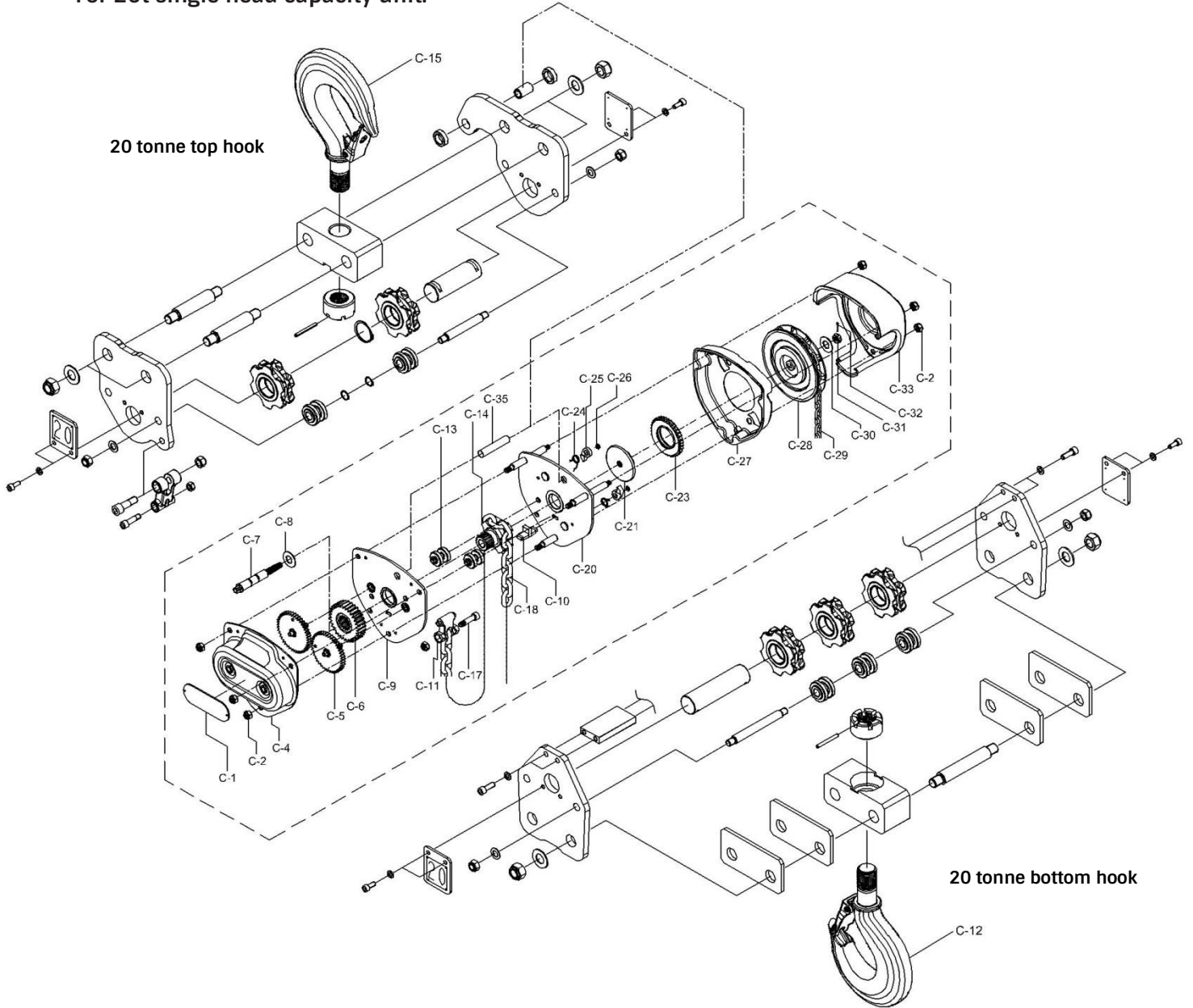

Part No.	Qty	Part Name	Part No.	Qty	Part Name	Part No.	Qty	Part Name
C-1	1	Label	C-12	1	Bottom Hook Assembly	C-25	2	Pawl
C-2	6	Nut	C-13	2	Load Chain Guide	C-26	2	Snap Ring for Pawl Pin
C-4	1	Gear Cover	C-14	1	Load Sheave	C-27	1	Brake Cover
C-5	2	Pinion (with Pinion Gear)	C-15	1	Top Hook Assembly	C-28	1	Hand wheel
C-6	1	Load Gear	C-17	1	Chain-End-Fixing Pin	C-29	1	Hand Chain
C-7	1	Pinion Shaft	C-18	1	Load Chain	C-30	1	Washer for Pinion Shaft Nut
C-8	1	Washer	C-20	1	Wheel-side Plate Assembly	C-31	1	Check/Castle Nut
C-9	1	Gear-side Plate	C-21	1	Disc Hub	C-32	1	Cotter/Split Pin for Check Nut
C-10	1	Chain Stripper	C-23	1	Brake Discs/ Ratchet Gear (bonded)*	C-33	1	Hand wheel Cover
C-11	1	Load Chain Anchoring	C-24	2	Pawl Spring	C-35	1	Top Hook Pin

*The C-23 Brake Discs/Ratchet Gear will generally come as a bonded unit (C-2223) but sometimes they may be separate parts (2xC-22, 1xC-23).





For 20t twin head capacity unit:

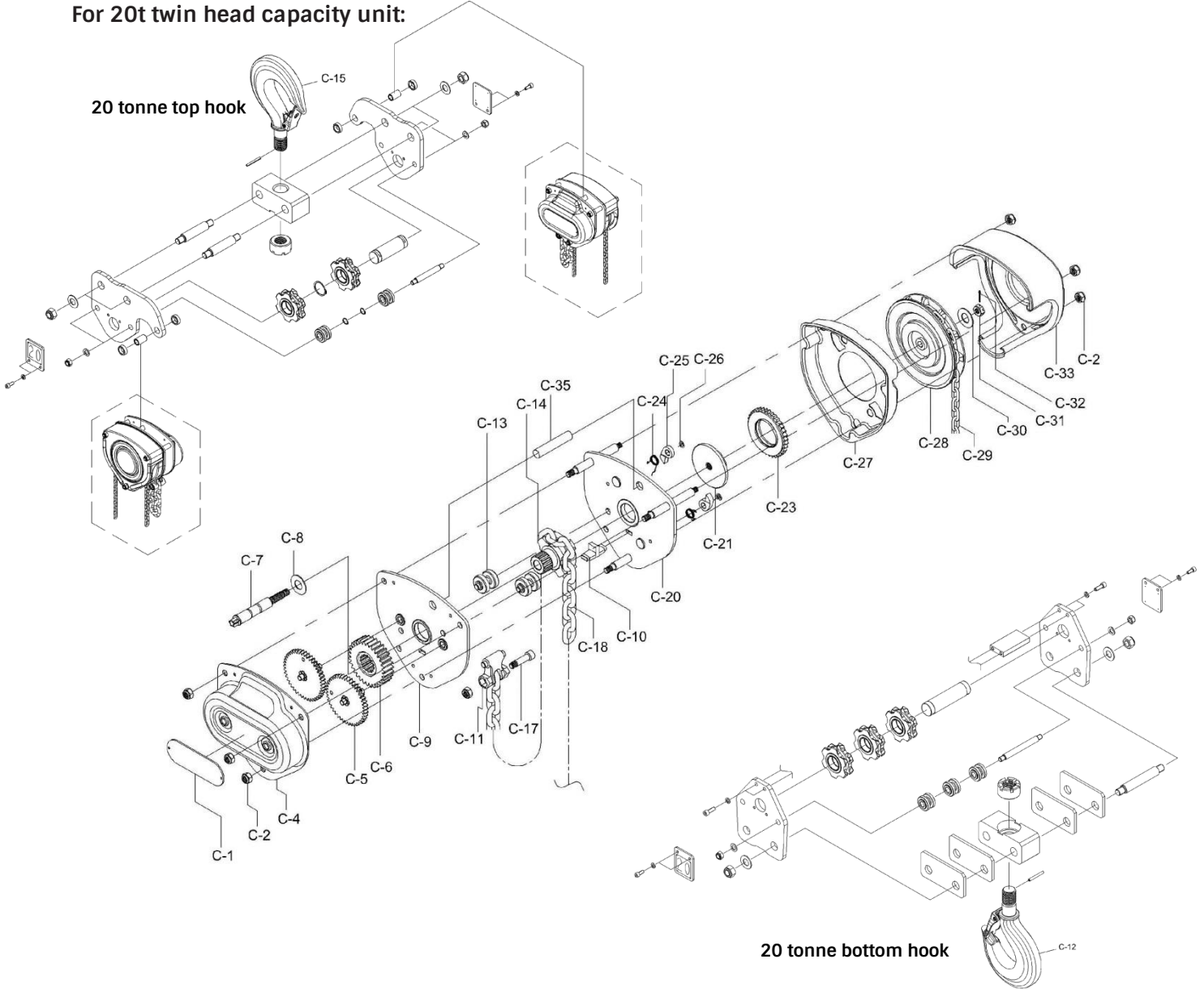

Part No.	Qty	Part Name	Part No.	Qty	Part Name	Part No.	Qty	Part Name
C-1	1	Label	C-12	1	Bottom Hook Assembly	C-25	2	Pawl
C-2	6	Nut	C-13	2	Load Chain Guide	C-26	2	Snap Ring for Pawl Pin
C-4	1	Gear Cover	C-14	1	Load Sheave	C-27	1	Brake Cover
C-5	2	Pinion (with Pinion Gear)	C-15	1	Top Hook Assembly	C-28	1	Hand wheel
C-6	1	Load Gear	C-17	1	Chain-End-Fixing Pin	C-29	1	Hand Chain
C-7	1	Pinion Shaft	C-18	1	Load Chain	C-30	1	Washer for Pinion Shaft Nut
C-8	1	Washer	C-20	1	Wheel-side Plate Assembly	C-31	1	Check/Castle Nut
C-9	1	Gear-side Plate	C-21	1	Disc Hub	C-32	1	Cotter/Split Pin for Check Nut
C-10	1	Chain Stripper	C-23	1	Brake Discs/ Ratchet Gear (bonded)*	C-33	1	Hand wheel Cover
C-11	1	Load Chain Anchoring	C-24	2	Pawl Spring	C-35	1	Top Hook Pin

*The C-23 Brake Discs/Ratchet Gear will generally come as a bonded unit (C-2223) but sometimes they may be separate parts (2xC-22, 1xC-23).





For 30t twin head capacity unit:

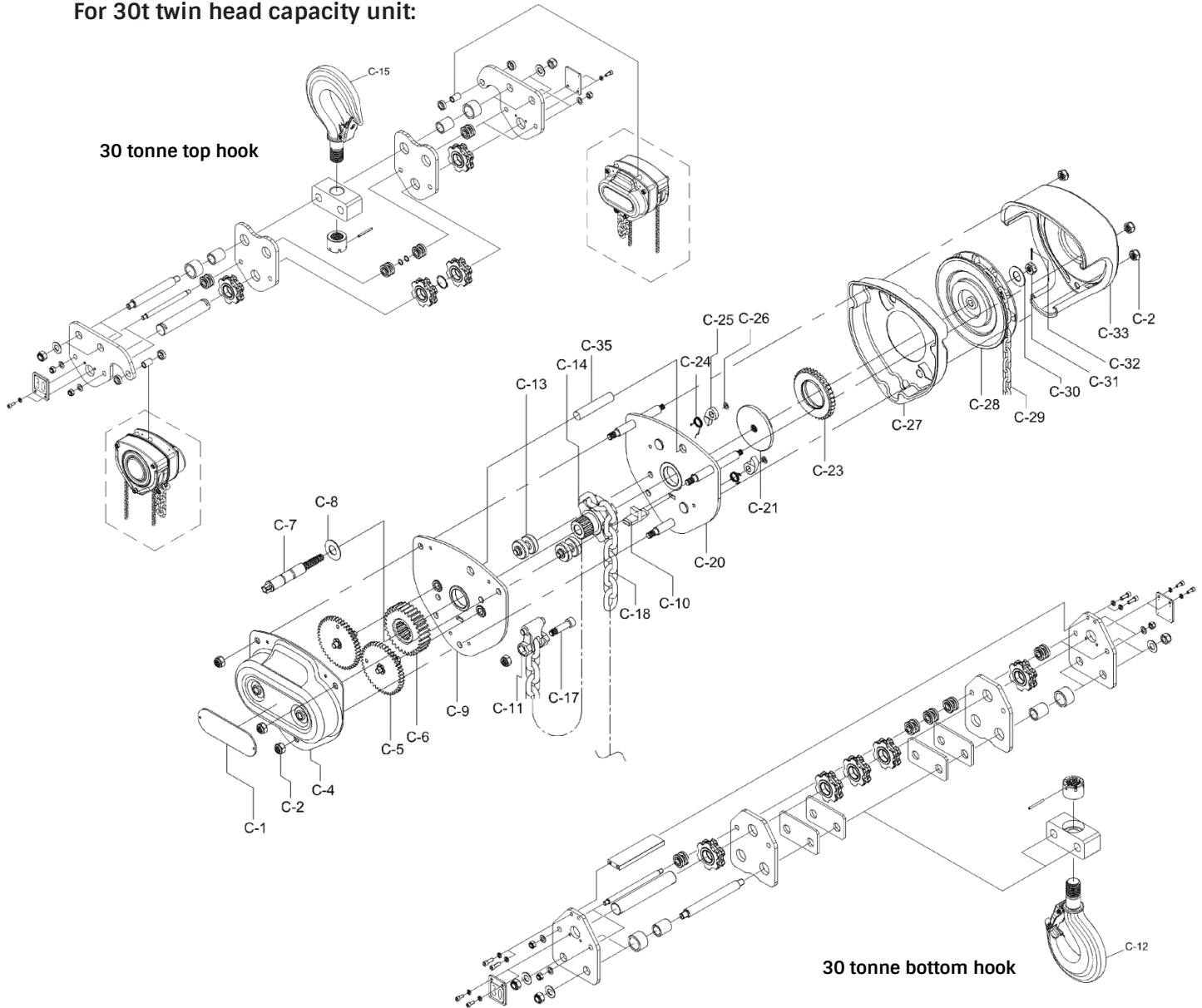

Part No.	Qty	Part Name	Part No.	Qty	Part Name	Part No.	Qty	Part Name
C-1	1	Label	C-12	1	Bottom Hook Assembly	C-25	2	Pawl
C-2	6	Nut	C-13	2	Load Chain Guide	C-26	2	Snap Ring for Pawl Pin
C-4	1	Gear Cover	C-14	1	Load Sheave	C-27	1	Brake Cover
C-5	2	Pinion (with Pinion Gear)	C-15	1	Top Hook Assembly	C-28	1	Hand wheel
C-6	1	Load Gear	C-17	1	Chain-End-Fixing Pin	C-29	1	Hand Chain
C-7	1	Pinion Shaft	C-18	1	Load Chain	C-30	1	Washer for Pinion Shaft Nut
C-8	1	Washer	C-20	1	Wheel-side Plate Assembly	C-31	1	Check/Castle Nut
C-9	1	Gear-side Plate	C-21	1	Disc Hub	C-32	1	Cotter/Split Pin for Check Nut
C-10	1	Chain Stripper	C-23	1	Brake Discs/ Ratchet Gear (bonded)*	C-33	1	Hand wheel Cover
C-11	1	Load Chain Anchoring	C-24	2	Pawl Spring	C-35	1	Top Hook Pin

*The C-23 Brake Discs/Ratchet Gear will generally come as a bonded unit (C-2223) but sometimes they may be separate parts (2xC-22, 1xC-23).





Load Limiter C-40 (where fitted)

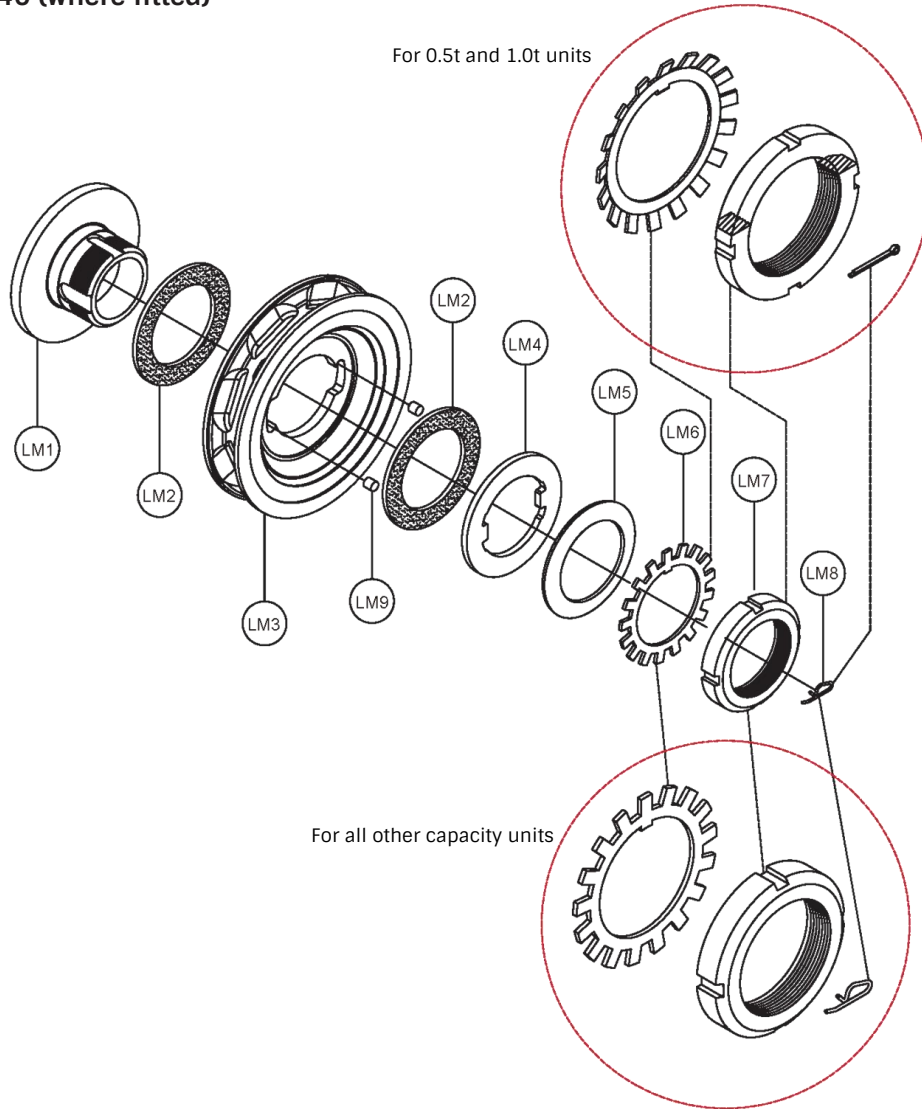

Capacity	LM6	LM7	LM8
0.5t/1.0t	Curved	Chamfer facing in, towards LM6	Cotter/Split pin
1.5t/2.0t/3.0t/5.0t/8.0t/10.0t/15.0t/20.0t/30.0t	Flat	Chamfer facing out, towards LM8	R clip

Part No.	Part Name	Part No.	Part Name	Part No.	Part Name
LM1	Hub	LM4	Pressure plate	LM7	Lock nut
LM2	Friction plate	LM5	Spring disc	LM8	R clip (or split pin for 0.5t and 1.0t capacity units)
LM3	Hand chain wheel	LM6	Tab washer	LM9	Stud





14. Inspection Log

Test Certificate/DOC Number	Model Number	Product Description

Date introduced into service		Serial Number	
------------------------------	--	---------------	--

Date	Comments	Signature





Tiger



Owner's Notes





Tiger Taiwan

Woo Sing Industrial Co., Ltd

No 20 Yunong Road

Shih-lin

Taipei

Taiwan

Phone: +886-2-2831 3035

Fax: +886-2-2834 0188

info@tigerlifting.com.tw

Tiger UK

Tiger Lifting UK Limited

Unit 1, Greensfield Industrial Estate

Willowburn Avenue

ALNWICK

NE66 2DG

UK

Phone: +44 1665 605130

Fax: +44 1665 603185

info@tigerlifting.com

☎ Representative in Europe

www.tigerlifting.com



© Copyright Tiger Lifting UK Limited. No part of this manual shall be reproduced, transmitted, transcribed, translated into any language human or electronic, stored in any electronic retrieval system, in any form without the written permission of Tiger Lifting UK Limited, Alnwick, UK

www.tigerlifting.com



Manual Tiger TCB-SS12 En 201605 v3.1